

## PUCK/PACKAGE DIVERT MODULE

- Pneumatic one-to-two lane diverter
- Compatible with round or rectangular packages or pucks
- Product can run back to back or paced for individual product divert
- UHMW divert arms for non-marking divert surface
- Includes flow controls with push-in air line connection
- Requires photo sensors, pneumatic solenoid valves, wiring and programming
- Rate depends on product size and desired flow. Contact factory for details.

### FEATURES & SPECIFICATIONS

- Available on FlexMove Aluminium Conveyors, FS (65 mm), FM (85 mm), FC (105 mm), FL (150 mm), FU (180 mm) and FV (260 mm)
- Product must be able to stand unsupported
- Min. single product weight: 0.2 kg (0.45 lbs)
- Max. single product weight: 5 kg (11 lbs)
- Max. product height: 150 mm (5.9 in)
- Max. product width: chain width (example: FM 85 mm)

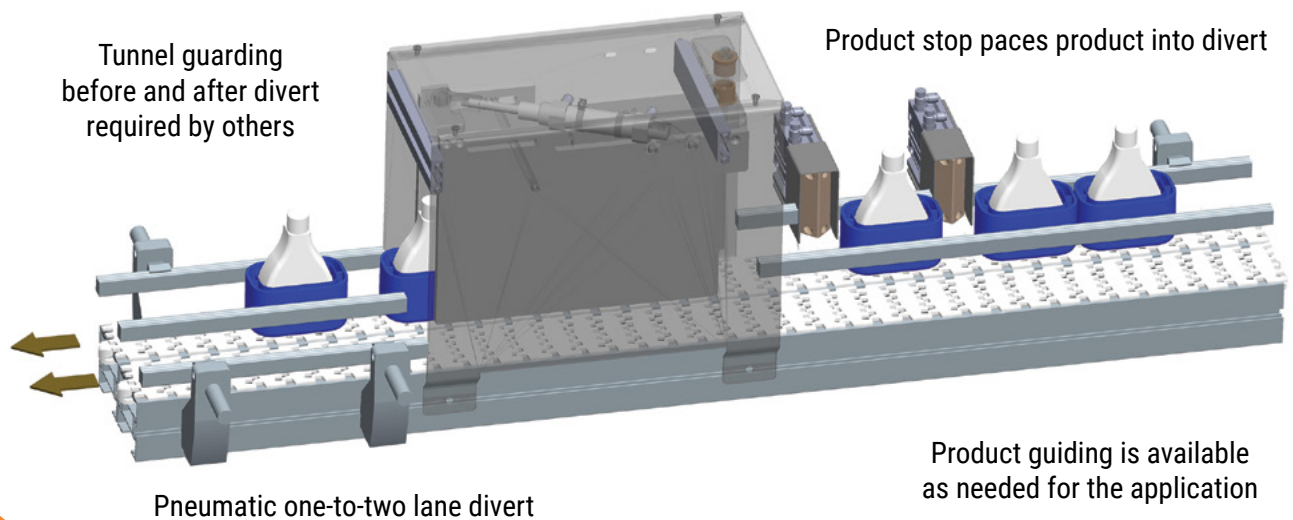

## DIMENSIONS

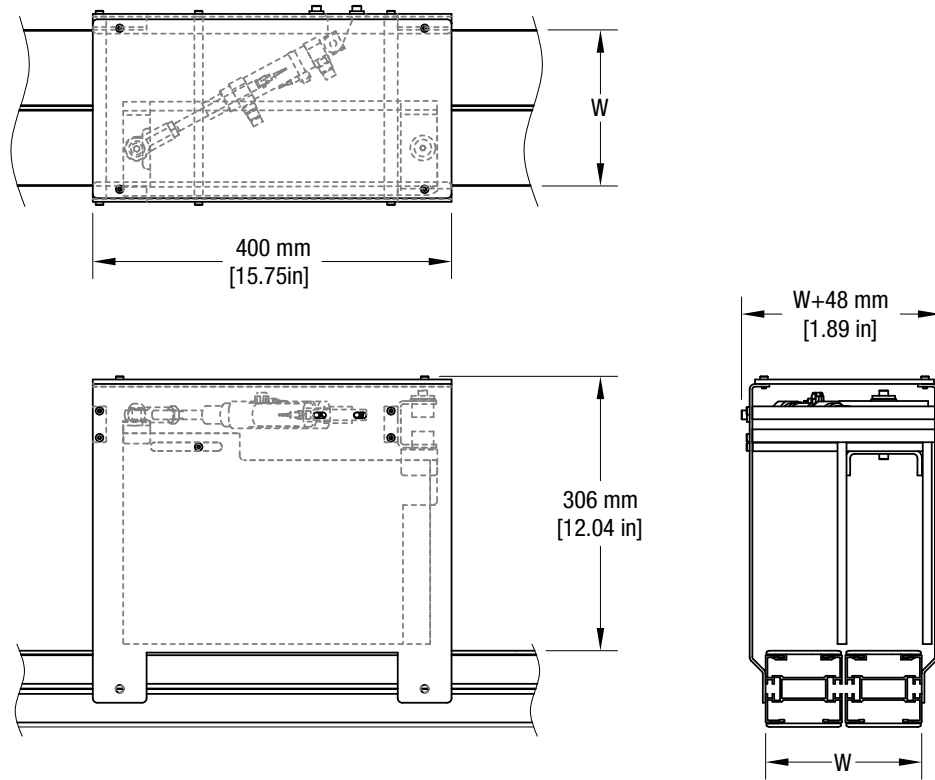

Part Number: 208162 for FM Series. Contact factory for other sizes.

Product dimensions shown for FM Series conveyors. Contact factory for other conveyor series.

## TRANSFORMING CONVEYOR AUTOMATION

### Dorner – North & South America

Dorner Mfg. Corp.  
USA  
+1-262-367-7600

Dorner Conveyors Ltd.  
Canada  
+1-289-208-7306

Dorner Latin America,  
S. de R.L. de C.V.  
+52.33.30037400

**DORNER**<sup>®</sup>  
By Columbus McKinnon

### Dorner – Europe

Dorner GmbH–Germany  
+49 (0) 2461/93767-0

Dorner SARL–France  
+33 (0)1 84 73 24 27

### Dorner – Asia

Dorner (M) Sdn. Bhd.  
Malaysia  
+604-626-2948

[dornerconveyors.com](http://dornerconveyors.com)

© Dorner Mfg. Corp. 2024.  
All Rights Reserved.  
851-955 0924