

WET CLEANING MODULE

- Wet Cleaning Module provides continuous cleaning of conveyor chain for applications with liquid or product overflow or package breakage
- Water jets spray outside and inside of the conveyor chain
- Series Driven Brush scrubs top and bottom surface of chain
- Air knives blow off water from chain
- Vacuum draws away excess water
- Designed to run continuously in production line
- Allows for longer, cleaner production runs with less overall maintenance
- Clean design with minimal area for dirt and debris to accumulate
- Fully encased components with cover designed for worker safety
- Completely mechanical, does not require electrical components, programming or secondary motor

FEATURES

- Available on FlexMove Stainless Steel Conveyors, SS (65 mm) and SM (85 mm)
- Size Requirement: 700 mm (L) x 700 mm (H)
- Minimum top of chain height: 750 mm (29.5 in)
- Maximum conveyor length: 4.5 m (14.8 ft)
- Maximum conveyor speed: 50 m/min (164 ft/min)

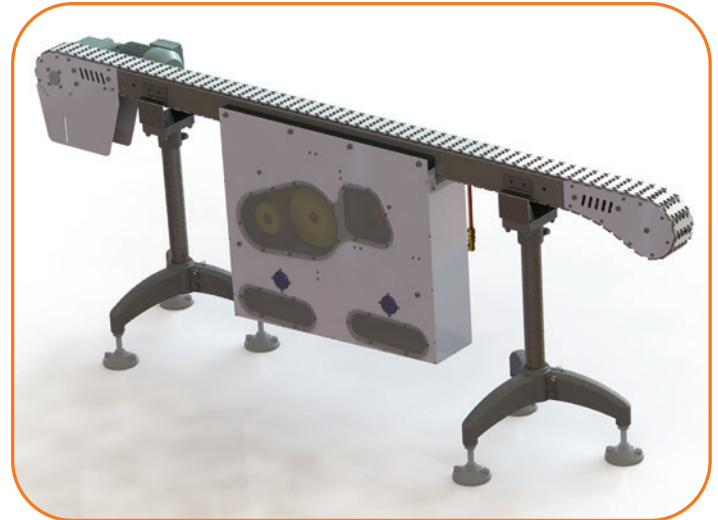

CHAIN CLEANING FLOW DIAGRAM

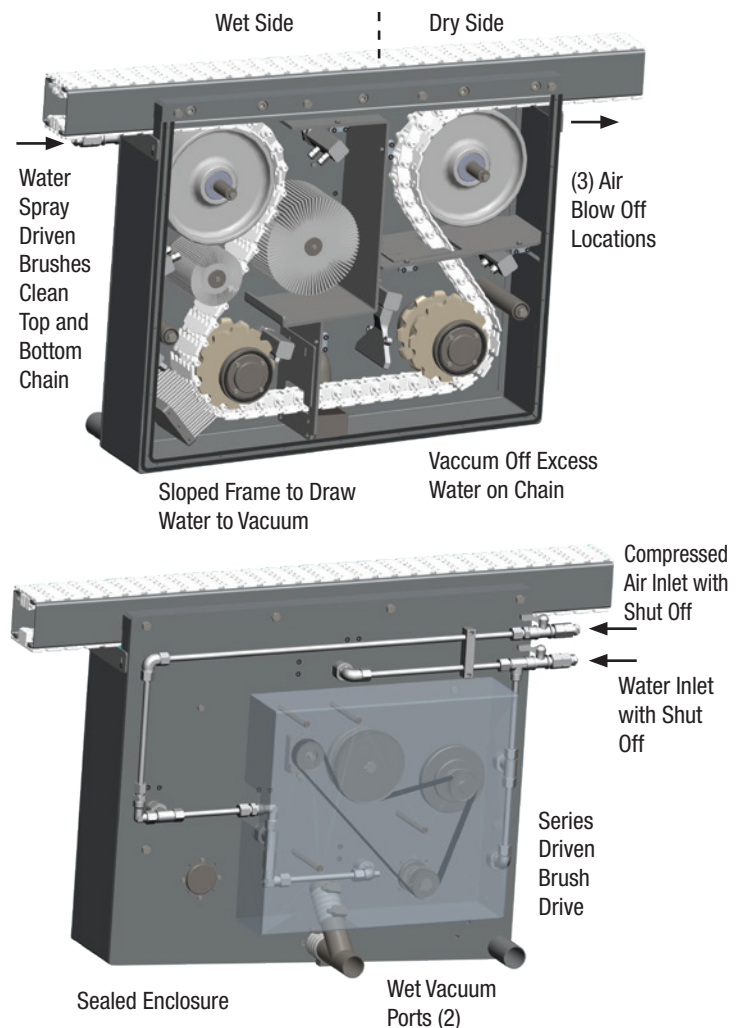

DIMENSIONS AND OPERATING REQUIREMENTS

Water Supply

- Connection 3/8 in NPT
- Normal operating pressure 0.98MPa. (140 psi)
- Flow rate required: ~13 litre/min (0.5 CFM)

Air Supply

- Connection: 8 mm tubing
- Air pressure required: 0.69 MPa (100 PSI)

Drying Vacuum

- Vacuum attachment: OD Ø38 mm, ID Ø34 mm pipe.
- Vacuum airflow required: ~56 litre/s (120 CFM), typical commercial grade wet/dry vacuum is acceptable

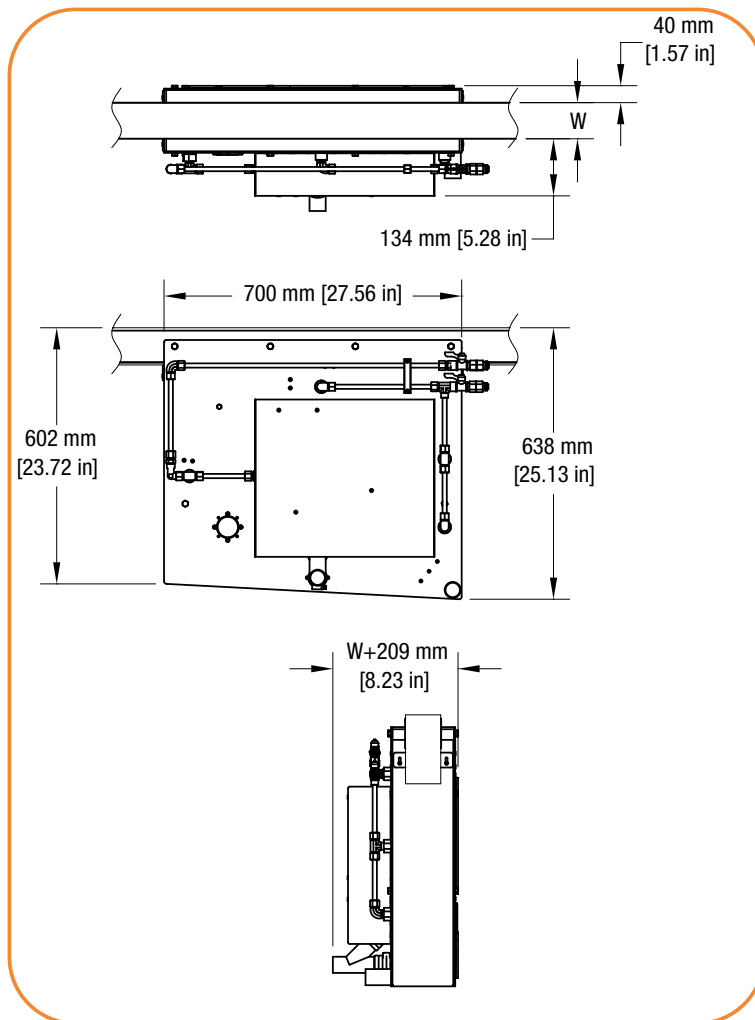

Note: Drive unit and idler selection to be consult upon ordering. Dorner reserves the right to make alteration without prior notification. Every care has been taken to ensure the accuracy of the information contained in this catalogue, but no liability can be accepted for any error or omissions

TRANSFORMING CONVEYOR AUTOMATION

Dorner – North & South America

Dorner Mfg. Corp.
Hartland, WI
USA
+1-262-367-7600
info@dorner.com

Dorner Conveyors Ltd.
Burlington, Ontario
Canada
+1-289-208-7306
info@dorner.com

Dorner Latin America, S. de R.L. de C.V.
Zapopan, Jalisco
Mexico
+52.33.30037400
info.latinamerica@dorner.com

DORNER®

By Columbus McKinnon

dornerconveyors.com

Dorner – Europe

Dorner GmbH
Jülich
Germany
+49 (0) 2461/93767-0
info.europe@dorner.com

Dorner SARL
Velizy-Villacoublay
France
+33 (0)1 84 73 24 27
info.france@dorner.com

Dorner – Asia

Dorner (M) Sdn. Bhd.
Penang
Malaysia
+604-626-2948
info.asia@dorner.com

© Dorner Mfg. Corp. 2023.
All Rights Reserved.
851-920 0723