

## DRY CLEANING MODULE

- Dry Cleaning Module provides continuous cleaning of conveyor chain for dry applications with powder, dust or other dry contaminates
- Slave Driven Rotary Brush scrubs chain surface, compressed air blows off particles, and vacuum extracts dust
- Designed to run continuously in production line
- Allows for longer, cleaner production runs with less overall maintenance
- Clean design with minimal area for dirt and debris to accumulate
- Fully encased components with cover designed for worker safety
- Completely mechanical, does not require electrical components, programming or secondary motor

### FEATURES & SPECIFICATIONS

- Available on FlexMove Aluminum Conveyors, FS (65 mm), FM (85 mm) and FC (150 mm)
- Size Requirement: 700 mm (L) x 300 mm (H)
- Minimum top of chain height: 250 mm (13.8 in)
- Maximum conveyor length: 4.5 m (14.8 ft)
- Maximum conveyor speed: 50 m/min (164 ft/min)
- Includes support stand mounting bracket

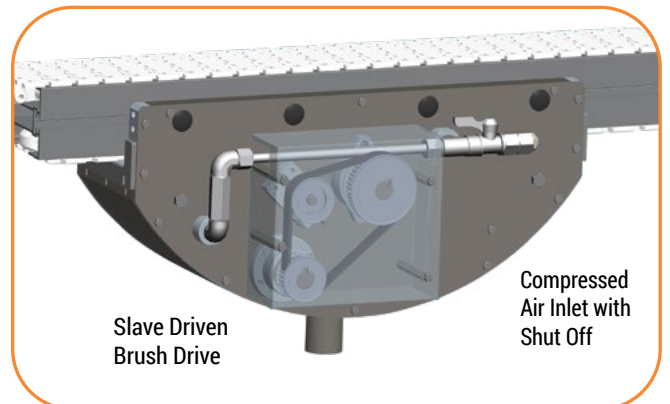
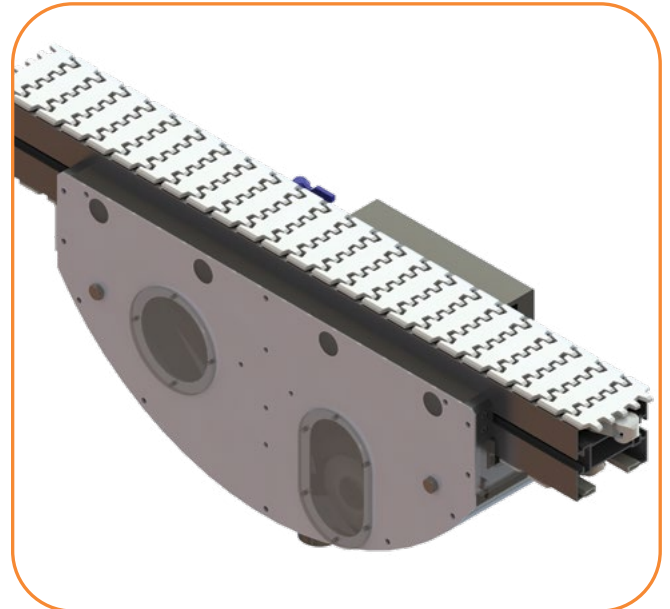

### CHAIN CLEANING FLOW DIAGRAM

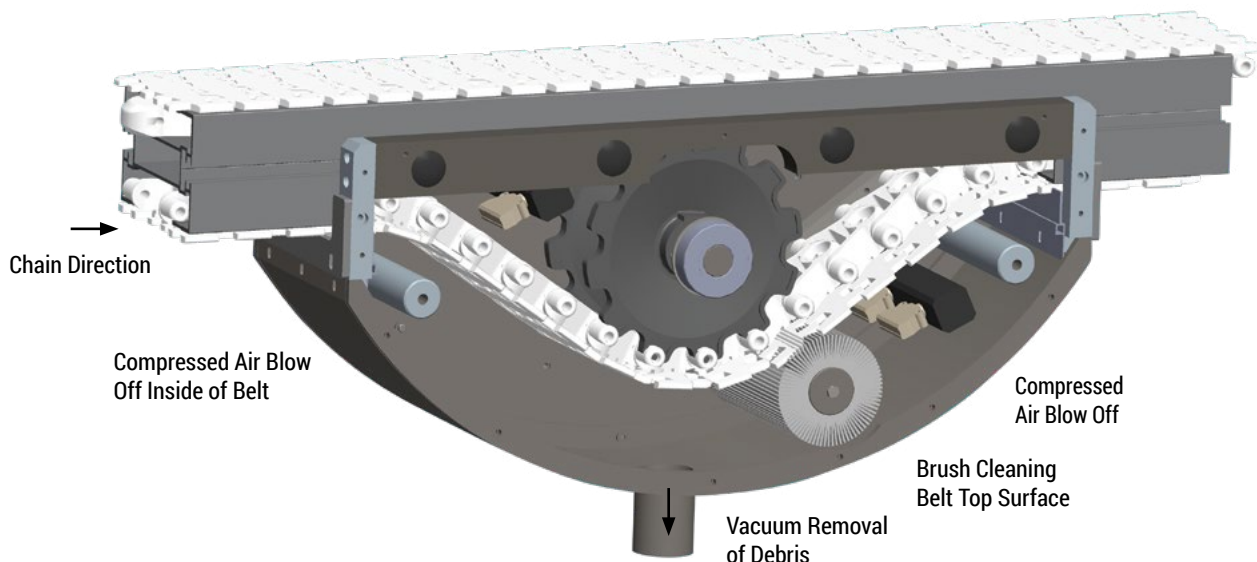

## DIMENSIONS AND OPERATING REQUIREMENTS

### Air Supply

- Incoming tubing size: M8
- Normal operating pressure 0.69 MPa (100 PSI)

### Drying Vacuum

- Vacuum attachment: OD Ø38 mm, ID Ø34 mm pipe
- Vacuum airflow required: ~56 litre/s (120 CFM)
- Typical commercial grade vacuum is acceptable

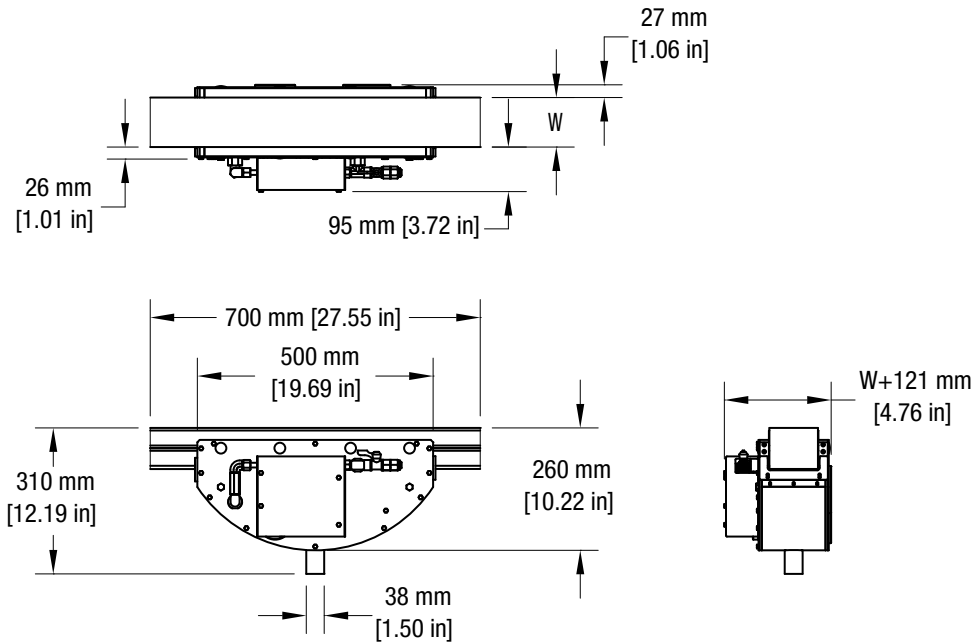

**Note:** Drive unit and idler selection to be consult upon ordering. Dorner reserves the right to make alteration without prior notification. Every care has been taken to ensure the accuracy of the information contained in this catalogue, but no liability can be accepted for any error or omissions

## TRANSFORMING CONVEYOR AUTOMATION

### Dorner – North & South America

**Dorner Mfg. Corp.**  
USA  
+1-262-367-7600

**Dorner Conveyors Ltd.**  
Canada  
+1-289-208-7306

**Dorner Latin America,**  
S. de R.L. de C.V.  
+52.33.30037400

**DORNER**<sup>®</sup>  
By Columbus McKinnon

### Dorner – Europe

**Dorner GmbH–Germany**  
+49 (0) 2461/93767-0

**Dorner SARL–France**  
+33 (0)1 84 73 24 27

### Dorner – Asia

**Dorner (M) Sdn. Bhd.**  
Malaysia  
+604-626-2948

[dornerconveyors.com](http://dornerconveyors.com)

© Dorner Mfg. Corp. 2024.  
All Rights Reserved.  
851-919 0924