

# ENGINEERING MANUAL

Complex Configurations  
& Tight Spaces

Ideal for Corrosion  
Resistant Applications

Reduces  
Conveyor Footprint

Capable of Curves,  
Inclines & Declines



**FlexMove** **STAINLESS**  
**SERIES**

High Performance, Stainless Steel,  
Flexible Chain Conveyors

**DORNER**  
By Columbus McKinnon

**TRANSFERS**  
FOR SMOOTH IN-LINE  
TRANSFER OF PRODUCT

**WHEEL CORNERS**  
ELIMINATE CORNER  
FRICTION ALLOWING  
MULTIPLE CORNER  
CONFIGURATIONS

**VERTICAL BENDS**  
FOR SMOOTH  
ELEVATION CHANGES  
AND EFFICIENT USE OF  
VERTICAL SPACE



**STAINLESS STEEL  
FRAMEWORK**  
FOR CORROSION  
RESISTANT APPLICATIONS

**SUPPORT POST**  
PROVIDE ADJUSTABLE  
HEIGHT WHILE OPTIMIZING  
THE USE OF FLOOR SPACE

**MODULAR FRAMING**  
FOR FUTURE ADD-ON  
CAPABILITY AND PRODUCTION  
LINE CHANGES

*The contents of this publication are the copyright of the publishers and may not be reproduced (even extracts) unless permission is granted. Every care has been taken to ensure the accuracy of the information but no liability can be accepted for any errors or omissions.*

*The right is reserved to make design modifications*

**Patents**

*Essential parts of the FlexMove product range are protected by patents and design regulations.*

*Drawings are made to European standards.*

*July 2024*

Product Overview & How to Purchase .....	4 – 5
Frame Widths .....	6 – 7
<b>SS</b> 65mm Conveyor System .....	8 – 18
<b>SM</b> 85mm Conveyor System .....	19 – 29
<b>SC</b> 105mm Conveyor System .....	30 – 39
<b>SU</b> 180 mm Conveyor System .....	40 – 46
<b>SV</b> 260 mm Conveyor System .....	47 – 53
<b>SA</b> Conveyor Accessories .....	54 – 57
<b>SG</b> Conveyor Guides .....	58 – 65
Gearmotors .....	66 – 67
Controllers .....	68 – 69
Technical Data & Calculations .....	70 – 80

*Dorner reserves the right to make alteration without prior notification. Every care has been taken to ensure the accuracy of the information contained in this Catalog but no liability can be accepted for any error or omissions.*



### Basic System Selection

We provide a wide selection of chain sizes to cover a wide variety of product sizes and shapes. In order to select the right chain size to use in your application, consider the following selection criteria:

- **Product Dimensions**  
A product can be two or three times wider than the conveyor chain as long as the center of gravity of the product falls within the chain width. Extra supporting guide rails are required and testing is recommended.
- **Product Weight**  
Product weight is important in chain selection as each chain has its maximum traction force. Traction force calculation is required when there are several heavy products to be conveyed, and it will increase further if the products are accumulated on the conveyor.
- **Technical Calculation**  
It is important to calculate total load on conveyor based on product weight, distance between products, accumulation and length of the system. The frequency of start /stop, chain tension and service factor are important. If the calculated capacity is higher than the selected drive and chain series, the conveyor should be shortened or select a system with higher capacity.
- **Small Footprint**  
Straightforward layout and compact design maximizes valuable floor space while minimizing noise, maintenance and footprint.

### Bends

Bends are used to change the direction of chain movement in conveyors. There are 3 types of bends available:

- **Wheel Bends**  
Designed with top and bottom wheels that rotate freely with the chain and are supported by a dual sealed ball bearing, providing the lowest friction, minimum bend force and smallest turning radius compared to other types of bends. Besides standard 30°, 45°, 60°, 90° and 180° configurations, special angles are also available upon request. Select a horizontal wheel bend whenever is possible.
- **Horizontal Bends**  
An alternative to wheel bends, horizontal bends are useful in conditions requiring large space, long products with large turning radius and twin – track bend applications. It has higher friction compared to wheel bends. Larger radius is recommended for lower friction and less stress on slide rail.
- **Vertical Bends**  
A vertical bend provides vertical change of the conveyors moving direction. It can be used either as a convex or concave bend. Vertical bends increase the chain tension and cause higher stress on the slide rail. Avoid using more than four 90° vertical bends in one conveyor.



### Slide Rail

A slide rail provides low friction and wear resistant track for the chain to slide on. It is mounted to a conveyor frame using screws or rivets. Various types of slide rails are available to meet different requirements like normal operation, high speed, high load, conductive and accumulation applications.

### Conveyor Frames

Conveyor frames are made of Stainless Steel provided in cut to length sizes to match the application. The conveyor side frame is provided with mounting locations for guides and support stands.

### Guide Rail Assembly System

Guide rail components are used to guide and contain products throughout the conveyor system and prevent them from falling off the conveyor. We provide a comprehensive range of Stainless Steel guide rails, and brackets either fixed or adjustable to cover many specialized product sizes and shapes.

### Structural System

Our Stainless Steel structural support system consists of Stainless support stands cut to the height of the application. Each support includes a tripod base for fine height adjustments.

### Conveyor Accessories

We offer a wide selection of conveyor accessories from special bolt & nuts, brackets, connecting strips, rivets, rollers, and washers for inter-connection between modules and components.

---

## HOW TO PURCHASE

### Purchasing a FlexMove Conveyor

Dorner offers three solutions for purchasing a FlexMove Conveyor.

- The first solution is to order all the necessary parts and components to build your FlexMove Conveyor on site. This will require the proper tools for cutting, bending and installing the conveyor. Consult our installation guide for FlexMove Conveyors for more details.
- The second solution is to have a complete conveyor provided through our FlexMove Solutions. With FlexMove Solutions, you can have the conveyor built in our facility, tested, broken down into shippable sections and shipped to the end site for installation.
- The third solution is to work with Dorner to have your FlexMove Conveyor assembled at the final site. The Conveyor will be purchased similar to option 2, but will be shipped as pre-cut and sized components. The Dorner installation team will then assemble and test the equipment at your location. Contact a Dorner representative for a quote on this service.

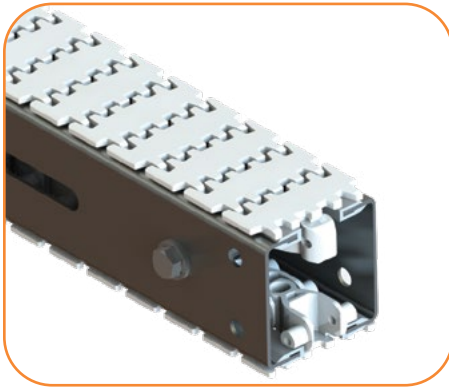

**65 mm (2.5 in)**

- Maximum load = 30 kg/m (20 lbs/ft)
- Maximum total load = 136 kg (300 lbs) non-accumulated
- Maximum length = 30 m (98 ft)
- Maximum Speed = 58 mpm (190 fpm)

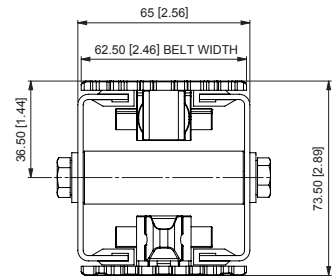

**65 MM WIDTH**

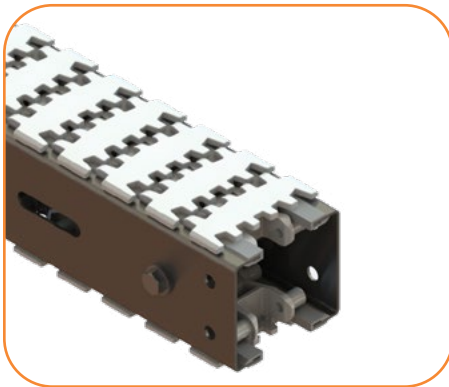

**85 mm (3.4 in)**

- Maximum load = 60 kg/m (40 lbs/ft)
- Maximum total load = 272 kg (600 lbs) non-accumulated
- Maximum length = 30 m (98 ft)
- Maximum Speed = 58 mpm (190 fpm)

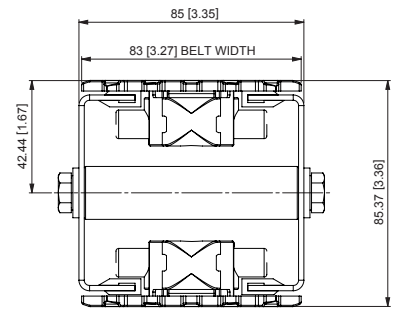

**85 MM WIDTH**

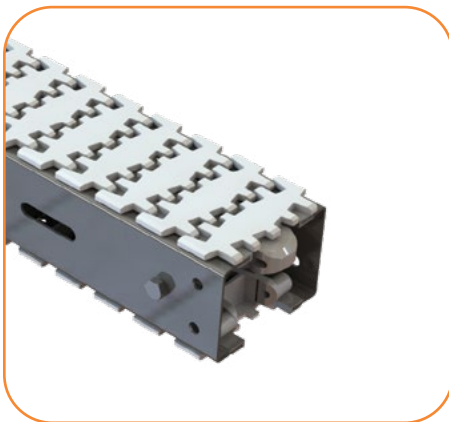

**105 mm (4.1 in)**

- Maximum load = 60 kg/m (40 lbs/ft)
- Maximum total load = 272 kg (600 lbs) non-accumulated
- Maximum length = 30 m (98 ft)
- Maximum Speed = 58 mpm (190 fpm)

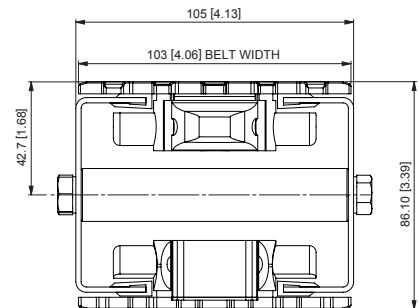

**105 MM WIDTH**

**Note:** Conveyor modules may be made up of several length of conveyor beam. Maximum length piece beam is 3,000 mm (118 in).

**Note:** Dimensions = mm (in)

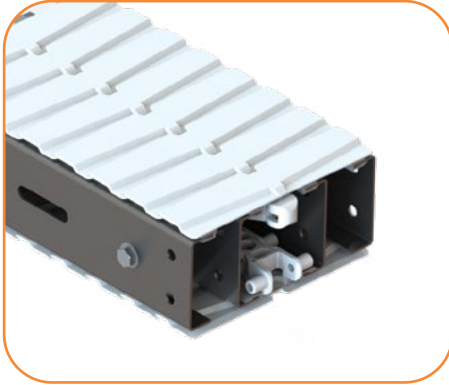

## 180 mm (7.1 in)

- Maximum load = 65 kg/m (44 lbs/ft)
- Maximum total load = 272 kg (600 lbs) non-accumulated
- Maximum length = 30 m (98 ft)
- Maximum Speed = 58 mpm (190 fpm)

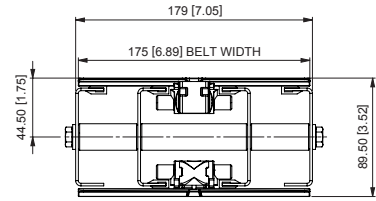

**179 MM WIDTH**



## 260 mm (10.2 in)

- Maximum load = 65 kg/m (44 lbs/ft)
- Maximum total load = 272 kg (600 lbs) non-accumulated
- Maximum length = 30 m (98 ft)
- Maximum Speed = 58 mpm (190 fpm)

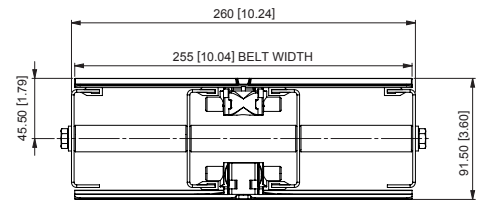

**260 MM WIDTH**

**Note:** Conveyor modules may be made up of several length of conveyor beam. Maximum length piece beam is 3,000 mm (118 in).

**Note:** Dimensions = mm (in)

## SS Series

### SS Series:

**Beam Width:** 65 mm

**Product Width:** Refer to Guide Rail Assembly

### Accessories Needed:

**Slide Rail Required:** FASR-25 OR FASR-25U

**Slide Rail Color:** White or Natural Color

**Slide Rail Material:** HDPE OR UHMW

**Slide Rail Rivet:** FASLS-M5

Connecting strip is used to connect 2 beams.

**Connecting Strip:** SACS-50x70

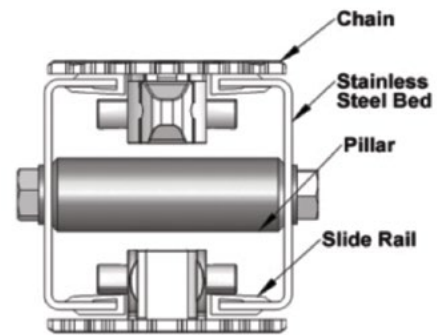
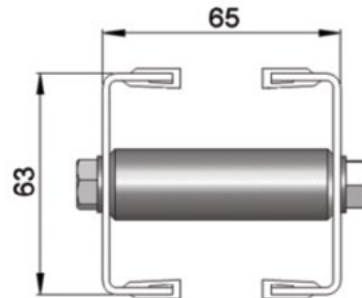

### Conveyor Beam SSCB-LXXXX

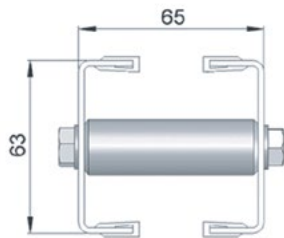

Where:  
XXXX = Length (mm)

UOM: each

### Chain Connecting Module SSCC-160

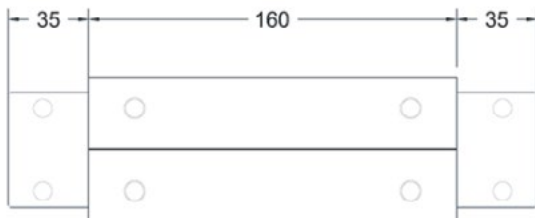

UOM: 3 Meter / Length

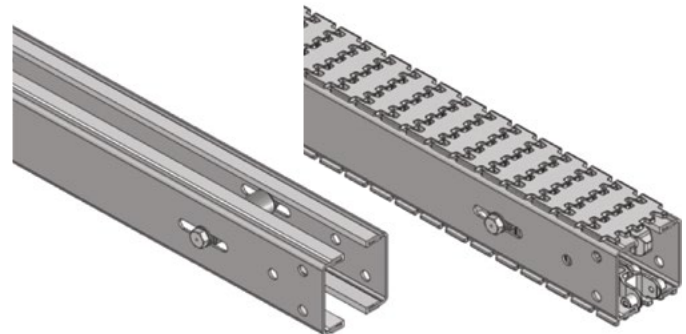

### Connecting Strip – Stainless Steel

SACS-50x70

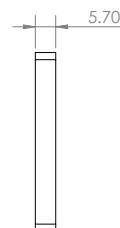
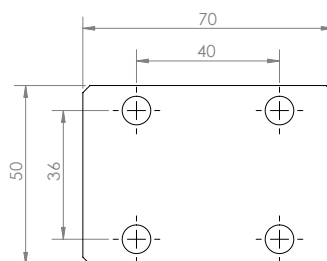
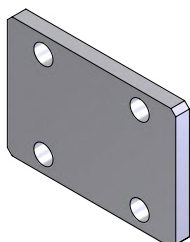

UOM: pc

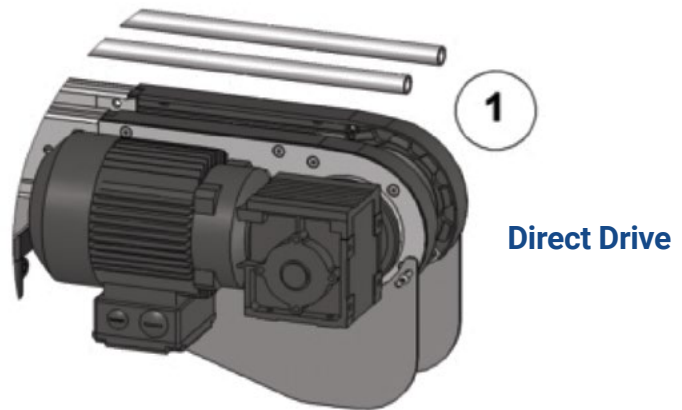



### Chain Common Data

**Packaging:** 5 m per box

**Pitch:** 25.4 mm

**Width:** 63 mm

Tensile Strength at 20°C: 4000N

**Color:** White & Black (Conductive)

### Material:

**Chain:** White Acetal / POM

**Pivot:** Polyamide

**Pivot Pin:** Stainless Steel

**Insert (Wedge & Friction):** TPE Grey

### Example for FSCT-5A17-L.#

# = 1 cleated top chain with alternate of # link of plain chain

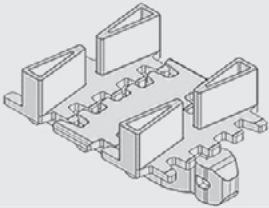

The above chain is FSCT-5A17-L1, 1 link cleated top chain with alternate of 1 link of plain chain.

**Note:** # = 1, 2, 3, 4, 5.....20

### Standard Plain Chain FSPC-5

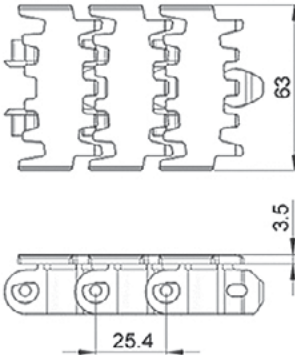
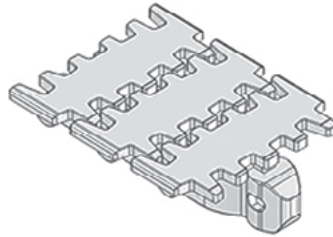

**UOM: 5 Meter / box**

Application: Suitable for horizontal and slope < 5° transport of products with accumulation.

### Universal Chain FSUC-5

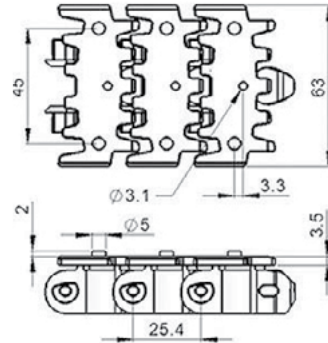
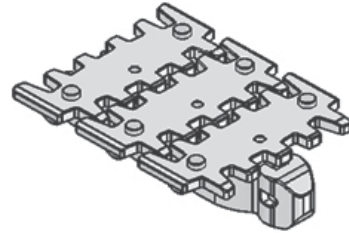

**UOM: 5 Meter / box**

Application: Universal Link with M3 Nut, Suitable for attached customer cleat or fixture

### Wedge Top Chain FSWT-5A

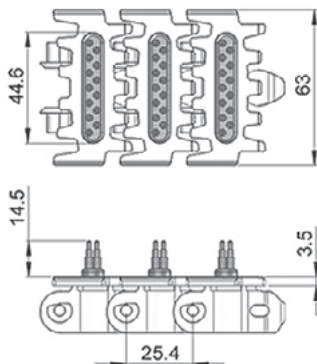
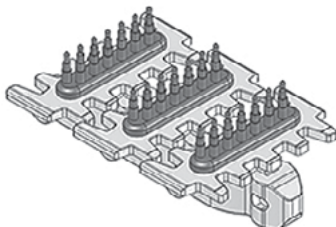

**UOM: 5 Meter / box**

Application: Vertical Wedge transportation of products.

### Wedge Top Chain FSWT-5C

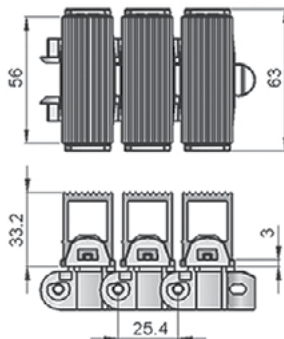
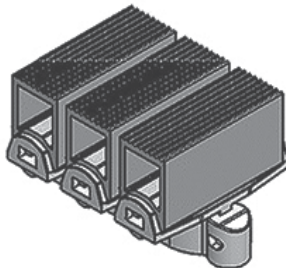

**UOM: 5 Meter / box**

Application: Vertical Wedge transportation of products. (Heavy Duty)

### Wedge Top Chain FSWT-5D

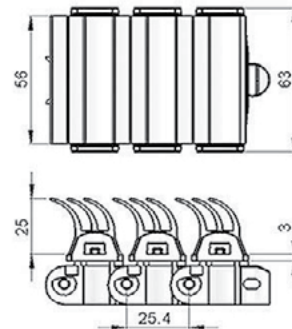
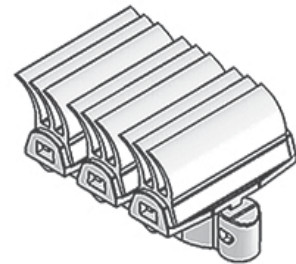

**UOM: 5 Meter / box**

Application: Vertical Wedge transportation of products.

Friction Top Chain **FSFT-5**

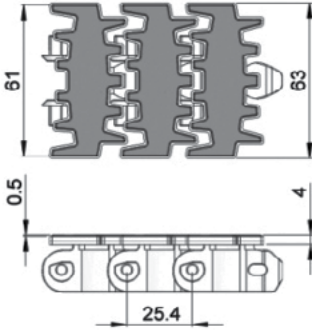
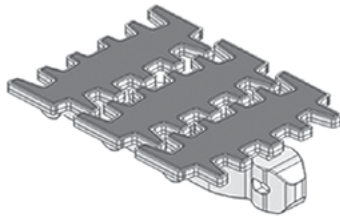

**UOM: 5 Meter / box**  
 Application: Suitable for transport product in slope > 5° but ≤ 30° without accumulation.

Friction Top Chain **FSFT-5C**

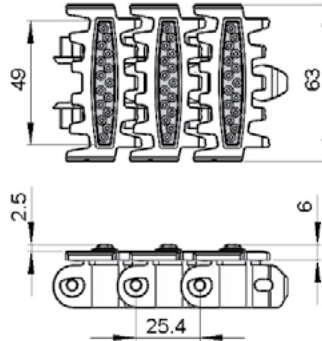
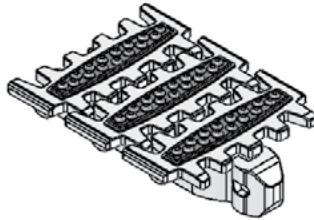

**UOM: 5 Meter / box**  
 Application: Suitable for transport product in slope > 5° but ≤ 35° without accumulation. Subject to product weight and packing

Twist Chain **FSPC-5M**

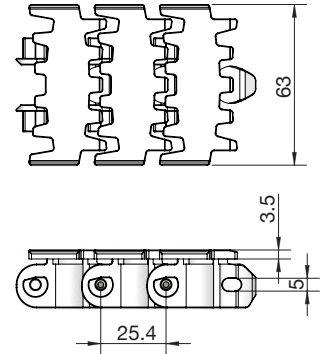
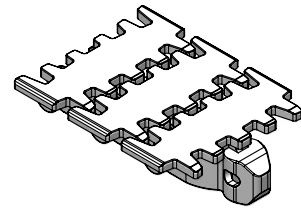

**UOM: 5 Meter / box**  
 Application: Suitable twist conveyor beam; horizontal and slope < 5° transport of products with accumulation

Conductive Chain **FSPC-5CD**

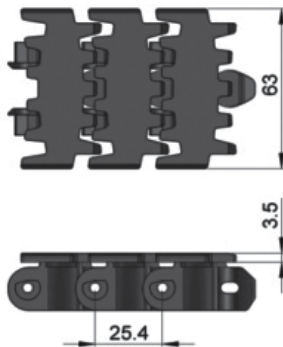
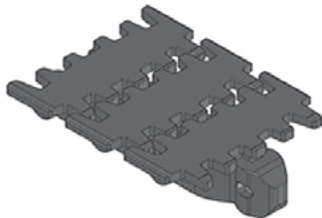

**UOM: 5 Meter / box**  
 Application: Suitable for transport of static sensitive product.

Flocked Chain **FSFK-5**

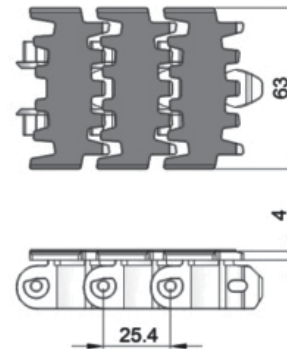
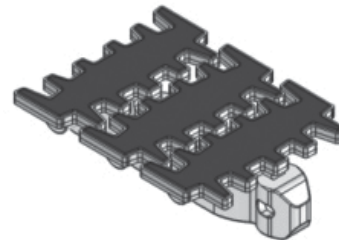

**UOM: 5 Meter / box**  
 Application: Suitable to transport lightweight, fragile and scratch sensitive product.

**Cleat Top Chain-A FSCT-5A17-L#**

# = 1, 2, 3, 4, 5.....20

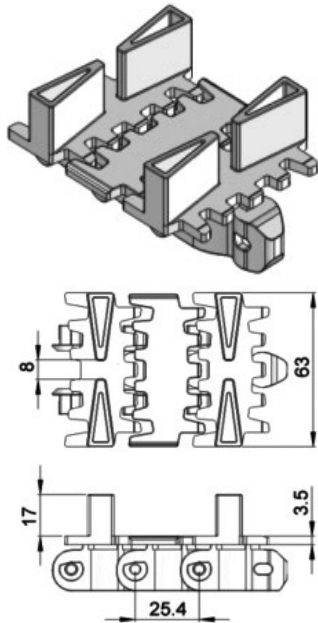

**UOM: 5 Meter / box**

Application: Suitable for vertical transport of product with no accumulation.

**Cleat Top Chain-A FSCT-5A30-L#**

# = 1, 2, 3, 4, 5.....20

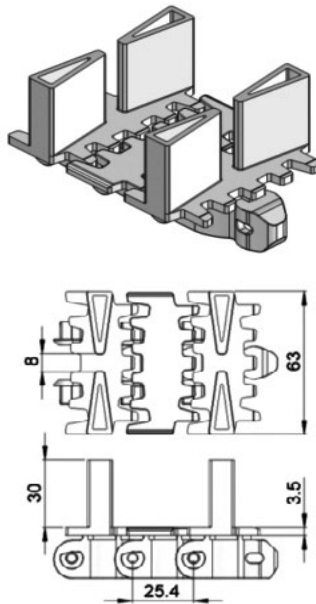

**UOM: 5 Meter / box**

Application: Suitable for vertical transport of product with no accumulation.

**Cleat Top Chain-B FSCT-5B**

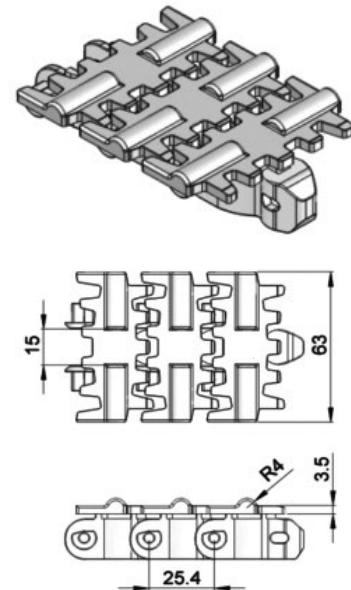

**UOM: 5 Meter / box**

Application: Suitable Cigarette transport.

**Cleat Top Chain-C FSCT-5C**

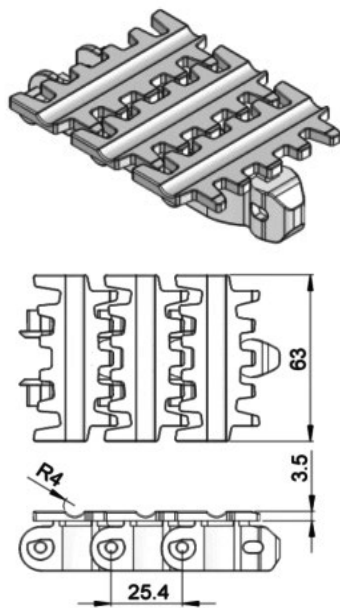

**UOM: 5 Meter / box**

Application: Suitable for Cigarette transport.

**Magnet Top Chain FSMT-5**

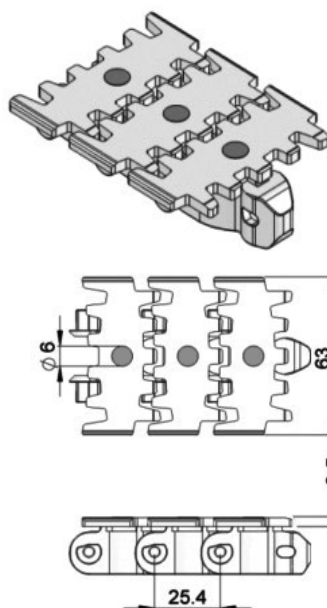

**UOM: 5 Meter / box**

Application: Suitable for conveying ferromagnetic products in slope.

**Magnet Top Chain FSMT-5-L#**

# = 1, 2, 3, 4, 5.....20

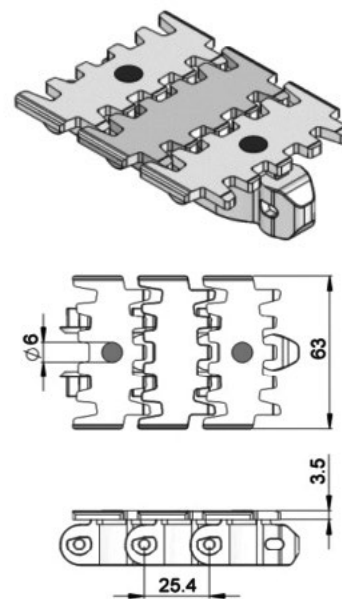

**UOM: 5 Meter / box**

Application: Suitable for conveying ferromagnetic products in slope.

Hardened Steel Top Chain **FSST-5**

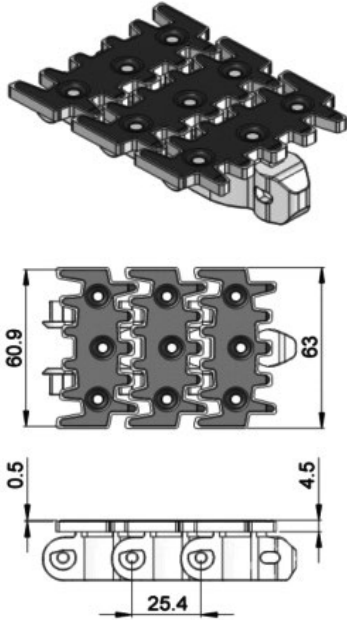

**UOM: 5 Meter / box**  
 Application: Suitable to transport metal products in accumulation.

Stainless Steel Top Chain **FSST-5S**

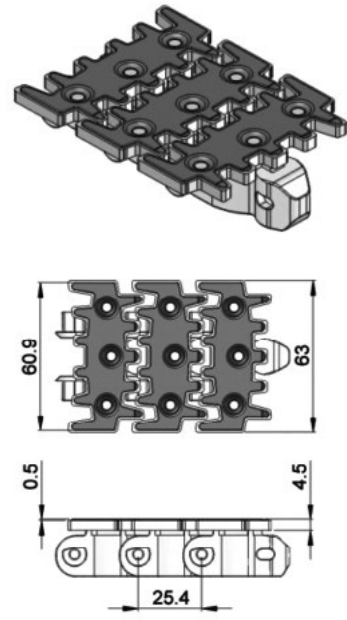

**UOM: 5 Meter / box**  
 Application: Suitable to transport metal products in accumulation.

Roller Top Chain **FSRT-5**

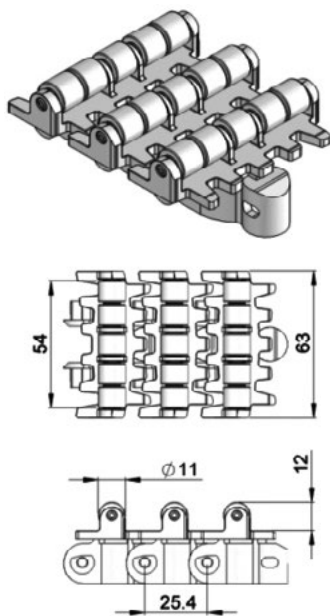

**UOM: 5 Meter / box**  
 Application: Suitable for accumulation of product with low friction and pressure.

Roller Cleat Chain **FSRC-5A-L#**

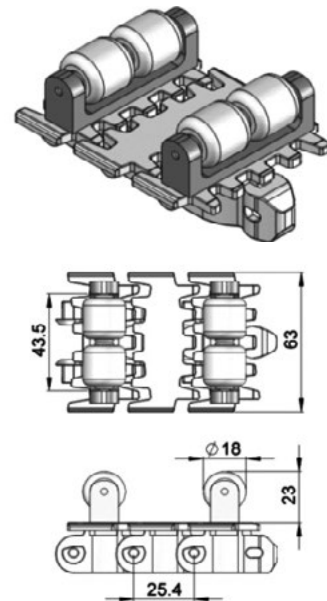

**UOM: 5 Meter / box**  
 Application: Suitable for vertical transportation, of product in slope with no accumulation.



**SS Direct End Drive without Motor (LEFT)**

SSDD-A65-0L

**SS Direct End Drive without Motor (RIGHT)**

SSDD-A65-0R

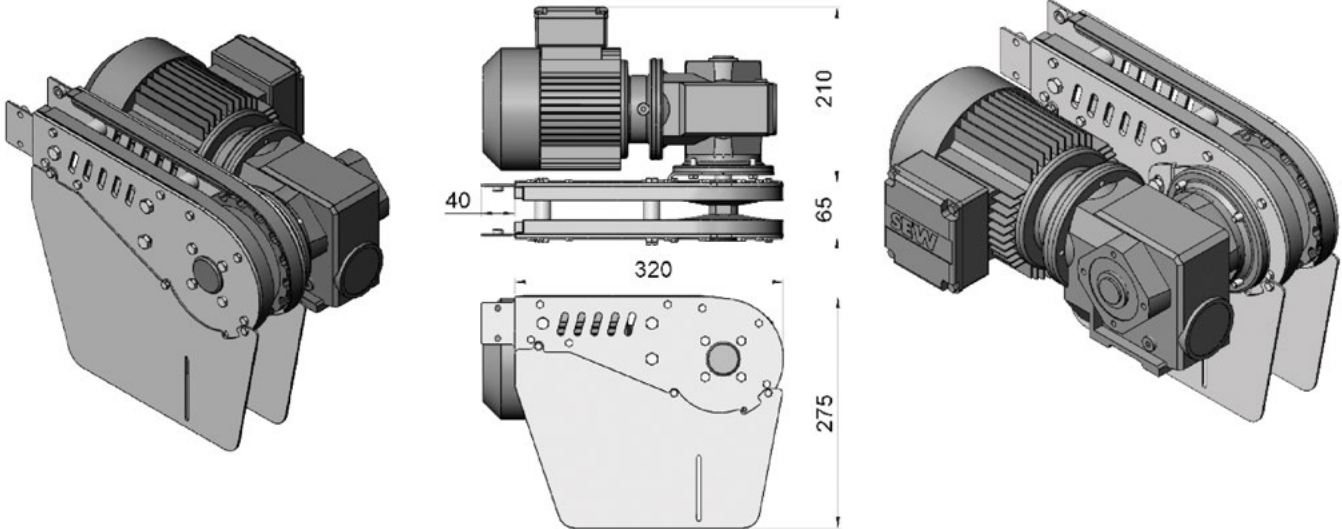

**Max Traction Force: 500N**

The standard Direct End Drive Unit is without torque limiter. See page 66-67 for Gearmotor options.

**UOM: pc**

Chain required 2-way: 0.8 meter    Slide rail required 2-way: 0.5 meter

**SS Direct End Drive without Motor GP (LEFT)**

SSDD-A65GP-0L

**SS Direct End Drive without Motor GP (RIGHT)**

SSDD-A65GP-0R

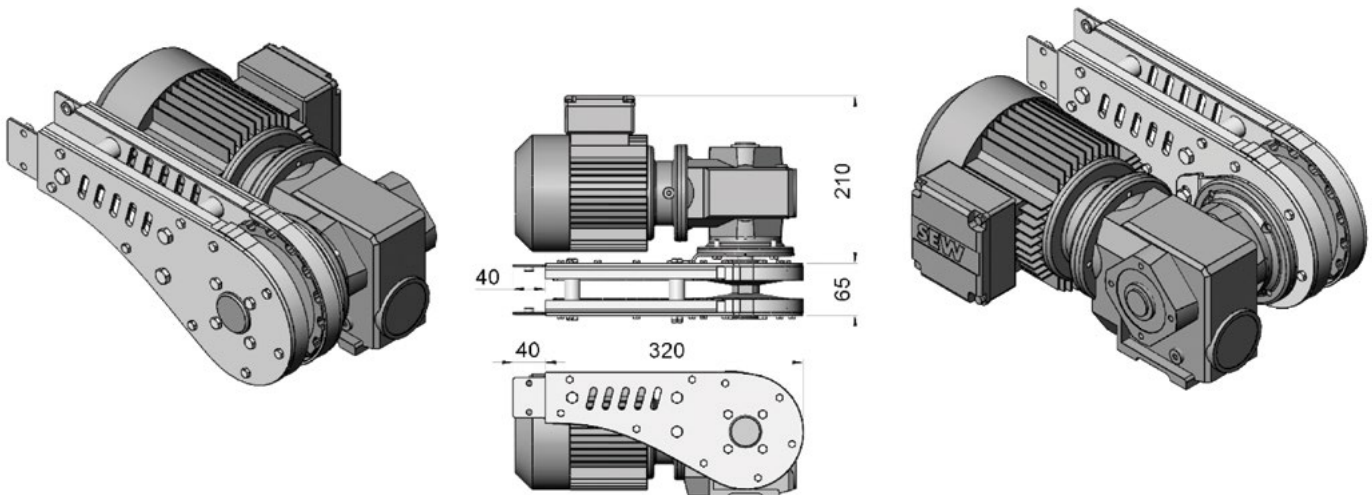

**Max Traction Force: 500N**

The Direct End Drive GP is used for vertical wedge conveyor. See page 66-67 for Gearmotor options.

**UOM: pc**

Chain required 2-way: 0.8 meter    Slide rail required 2-way: 0.5 meter

SEW gearmotors are products of SEW Eurodrive



SS Idler End-A65

SSIE-A65

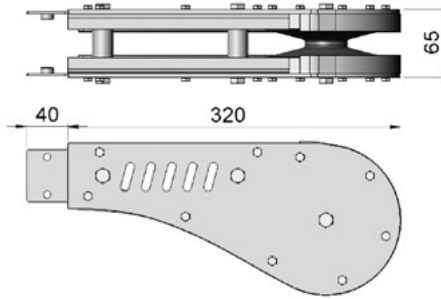
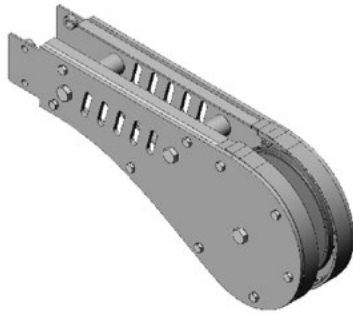

**UOM: pc**  
 Chain required 2-way: 0.8 meter  
 Slide rail required 2-way: 0.5meter

SS Wheel Bend 180°

SSWB-180R150A

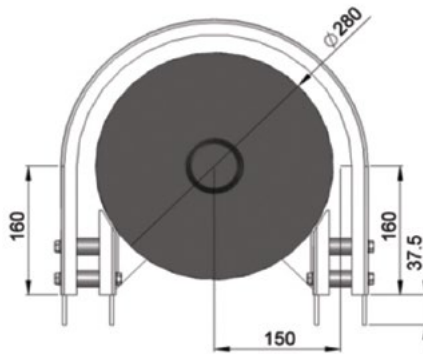
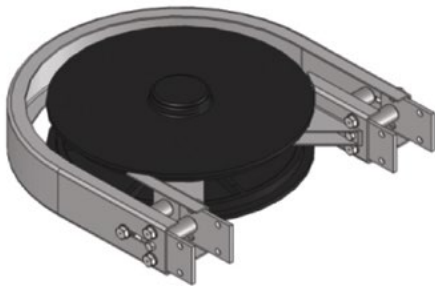

**UOM: pc**  
 Chain required 2-way: 1.4 meter  
 Slide rail required 2-way: 2.8 meter

SS Wheel Bend 90°

SSWB-90R150A

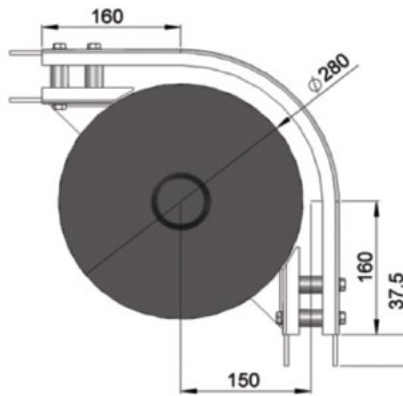

**UOM: pc**  
 Chain required 2-way: 0.9 meter  
 Slide rail required 2-way: 1.7 meter

SS Wheel Bend 45°

SSWB-45R150A

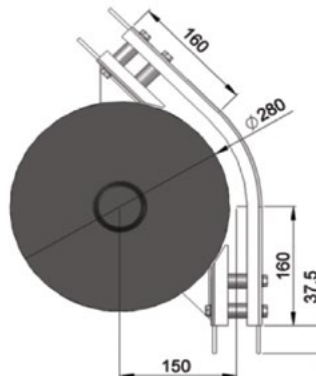
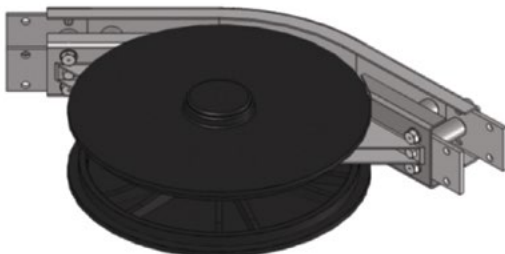

**UOM: pc**  
 Chain required 2-way: 0.6 meter  
 Slide rail required 2-way: 1.2 meter

**SS Wheel Bend 5° - 180°**

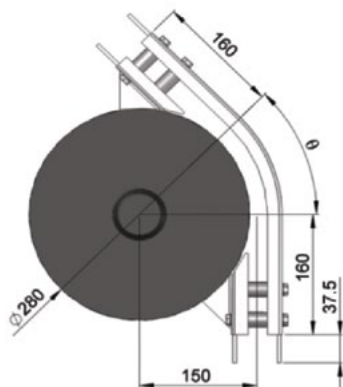

**Example for SS Wheel Bend Ordering**

- Wheel bend,  $\theta \pm 1^\circ$

If an angle of 65° is needed for wheel bend, the ordering part number is

**SSWB-65R150**

The outer bend is assembled using connecting strip (SACS-50x75). Angle of  $\theta^\circ$  must be indicated when ordering.

**SS Horizontal Plain Bend 30°**

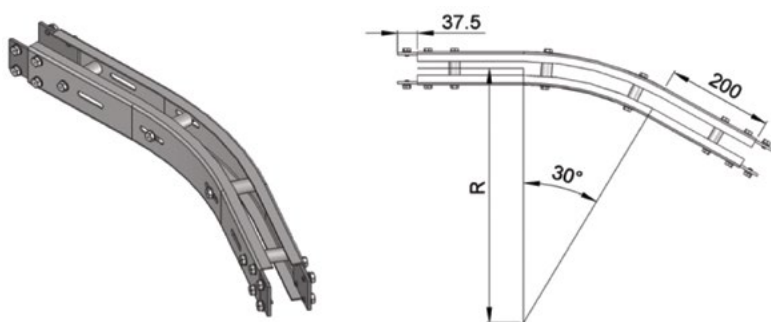

**Horizontal plain bend, 30° ± 1°**

- R = 500 ± 10 mm      **SSHB-30R500**
- R = 700 ± 10 mm      **SSHB-30R700**

**UOM: pc**

Chain required 2-way (500, 700): 1.4, 1.6 meter  
Slide rail required 2-way (500, 700): 2.8, 3.2 meter

**SS Horizontal Plain Bend 45°**

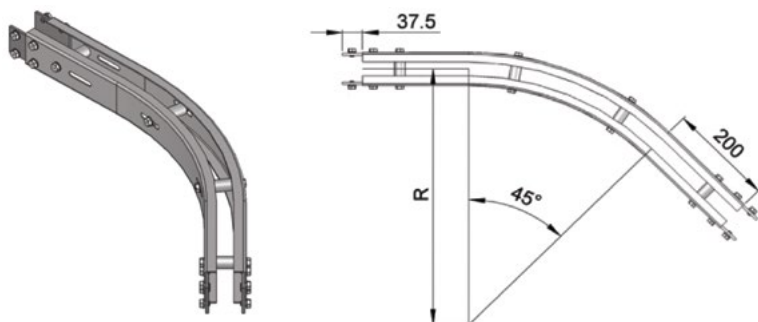

**Horizontal plain bend, 45° ± 1°**

- R = 500 ± 10 mm      **SSHB-45R500**
- R = 700 ± 10 mm      **SSHB-45R700**

**UOM: pc**

Chain required 2-way (500, 700): 1.6, 1.9 meter  
Slide rail required 2-way (500, 700): 2.9, 3.3 meter

**SS Horizontal Plain Bend 90°**

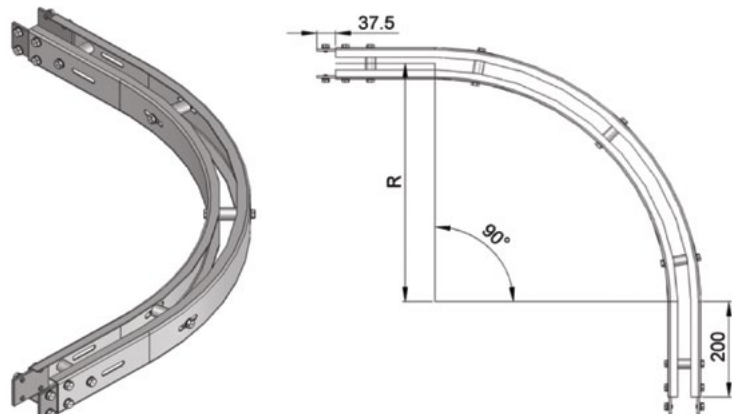

**Horizontal plain bend, 90° ± 1°**

- R = 500 ± 10 mm      **SSHB-90R500**
- R = 700 ± 10 mm      **SSHB-90R700**

**UOM: pc**

Chain required 2-way (500, 700): 2.4, 3.0 meter  
Slide rail required 2-way (500, 700): 4.8, 6.0 meter

SS Horizontal Plain Bend 5-180°

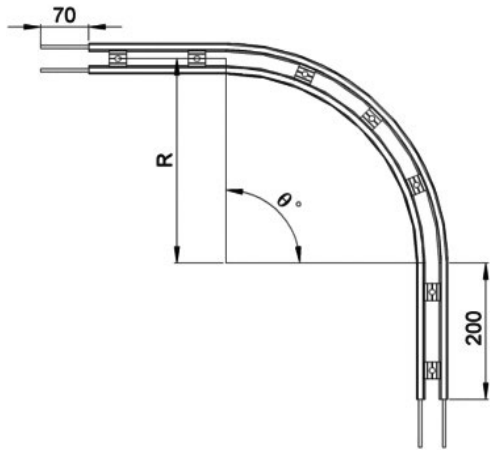

Example for SS Horizontal Plain Bend Ordering

Horizontal plain bend,  $\theta \pm 1^\circ$

- R = 500 ± 10 mm      SSHB-  $\theta^\circ$ R50
- R = 700 ± 10 mm      SSHB-  $\theta^\circ$ R700

If an angle of 120° is needed for radius R500 horizontal plain bend, the ordering part number is

**SSHB-120R500**

UOM: pc

Chain required 2-way (500, 700): meter (Variable to angle)

Slide rail required 2-way (500, 700): meter (Variable to angle)

SS Vertical Bend 5°      SSVB-5R300

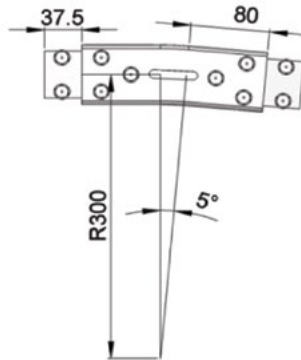
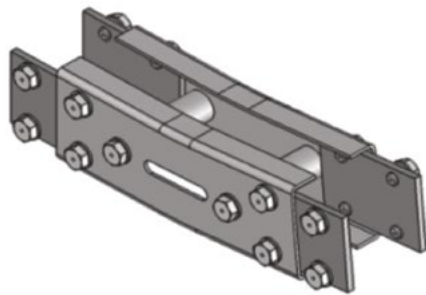

UOM: pc

Chain required 2-way: 0.4 meter

Slide rail required 2-way: 0.8 meter

SS Vertical Bend 15°      SSVB-15R300

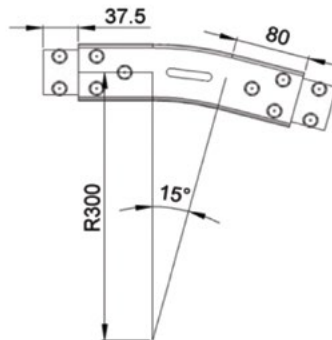
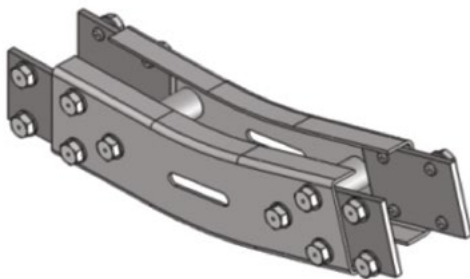

UOM: pc

Chain required 2-way: 0.6 meter

Slide rail required 2-way: 1.1 meter

SS Vertical Bend 30°      SSVB-30R300

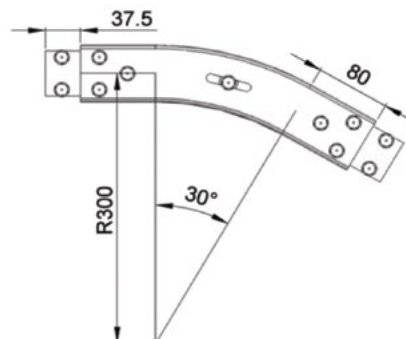
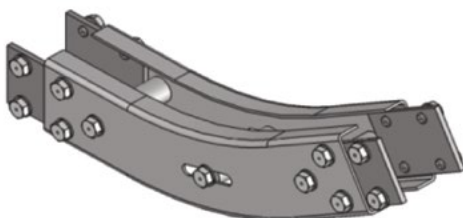

UOM: pc

Chain required 2-way: 0.8 meter

Slide rail required 2-way: 1.5 meter

**SS Vertical Bend 5° - 90°**

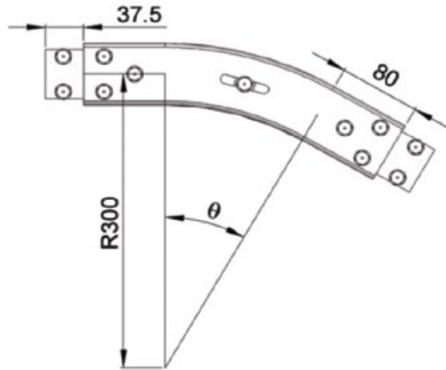

**Example for SS Vertical Bend Ordering**

- Vertical bend,  $\theta \pm 1^\circ$

If an angle of 25° is needed for vertical bend, the ordering part number is

**SSVB-25R300**

*The outer bend is assembled using connecting strip (SACS-50x75). Angle of  $\theta^\circ$  must be indicated when ordering.*

**SS Horizontal Beam Support Bracket – Stainless Steel**

**SAHBS-90S**

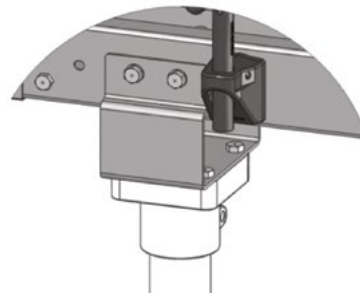
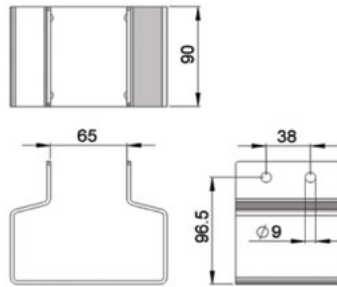
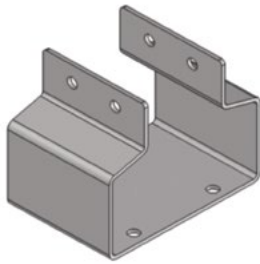

UOM: pc

**SS Adjustable Angle Beam Support Bracket**

**SAHBS-90S-A35**

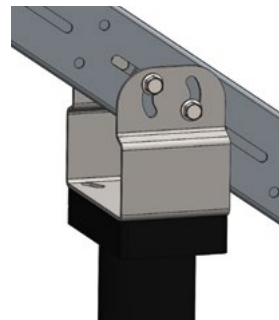
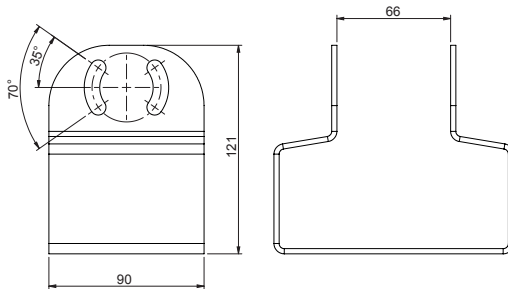

UOM: pc

**SS Horizontal Tripod Support**

**SBSS-HXXXX, where XXXX = H Height (mm)**

**SS Adjustable Angle Tripod Support**

**SBSS-A-HXXXX, where XXXX = H Height (mm)**

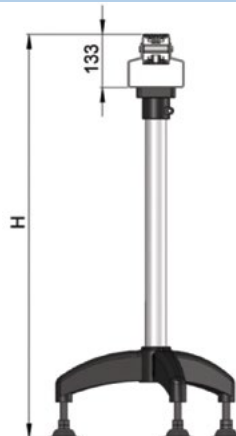

UOM: pc  
Includes Beam Support Bracket

## SM Series

### SM Series:

Beam Width: 85 mm

Product Width: Refer to Guide Rail Assembly

### Accessories Needed:

Slide Rail Required: FASR-25 OR FASR-25U

Slide Rail Color: White or Natural Color

Slide Rail Material: HDPE OR UHMW

Slide Rail Rivet & Screw: FASLS-M5

Connecting strip is used to connect two beams.

Connecting Strip: SACS-50x70

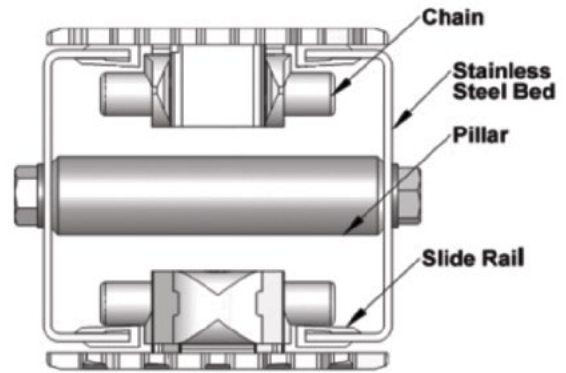

### Conveyor Beam SMCB-LXXXX

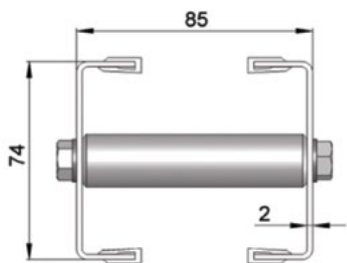

Where:  
XXXX = Length (mm)

UOM: each

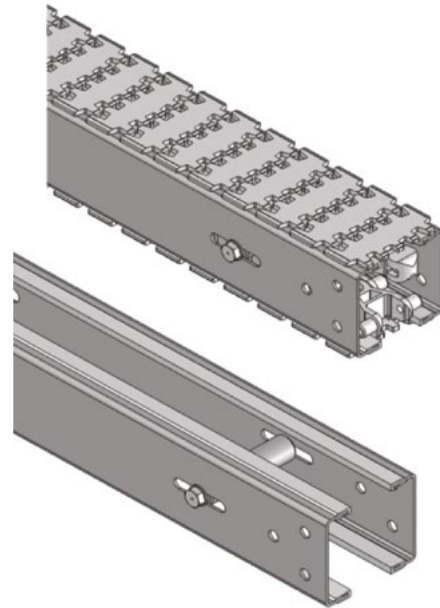

### Chain Connecting Module SMCC-160

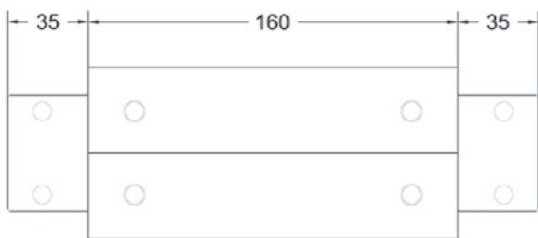

### Connecting Strip – Stainless Steel

SACS-50x70

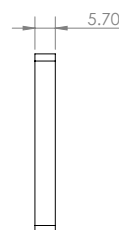
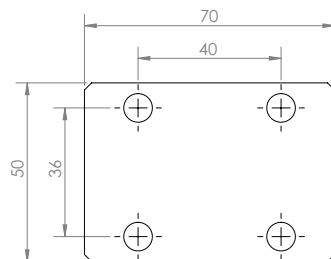
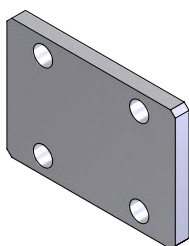

UOM: pc



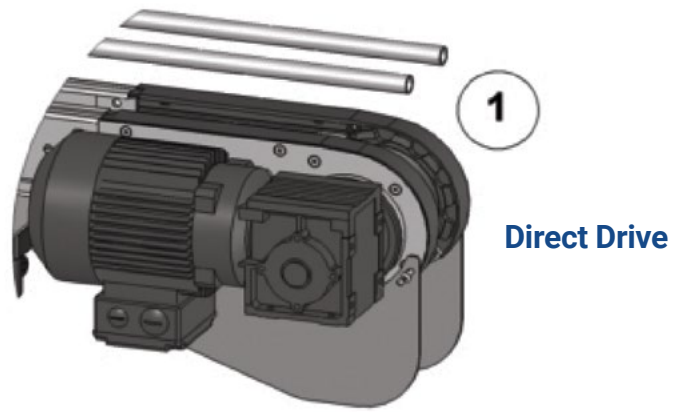
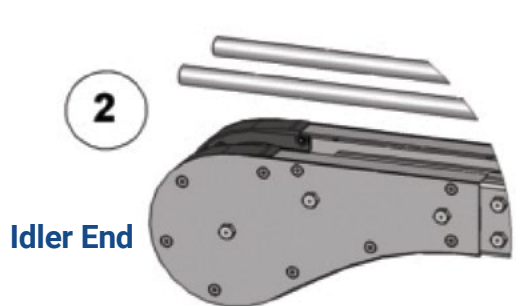

### Chain Common Data

**Packaging:** 5 m per box  
**Pitch:** 33.5 mm  
**Width:** 83 mm  
 Tensile Strength at 20°C: 6000N  
**Color:** White & Black (Conductive)

### Material:

**Chain:** White Acetal / POM  
**Pivot:** Polyamide  
**Pivot Pin:** Stainless Steel  
**Insert (Wedge & Friction):** TPE Grey

### Example for FMCT-5A17-L#

# = 1 cleated top chain with alternate of # link of plain chain

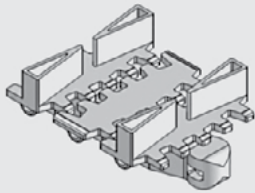

The above chain is FMCT-5A17-L1, 1 link cleated top chain with alternate of 1 link of plain chain.

**Note:** # = 1, 2, 3, 4, 5.....20

### Standard Plain Chain FMPC-5

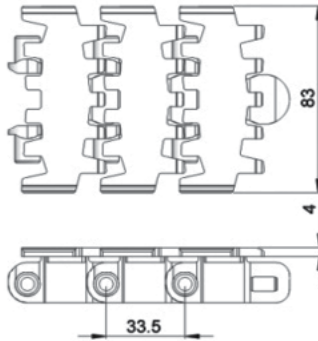
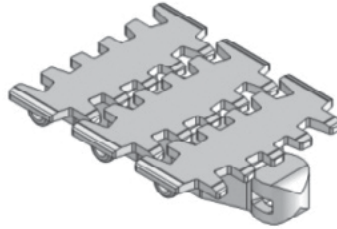

**UOM: 5 Meter / box**

Application: Suitable for horizontal and slope < 5° transport of products with accumulation.

### Conductive Chain FMPC-5CD

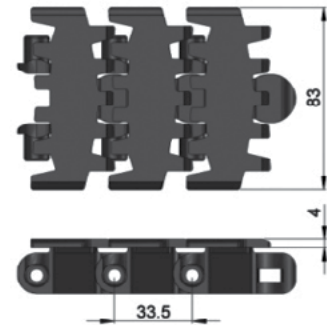
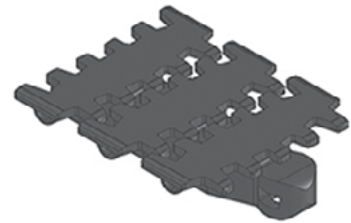

**UOM: 5 Meter / box**

Application: Suitable for transport of static sensitive product.

### Twist Chain FMPC-5M

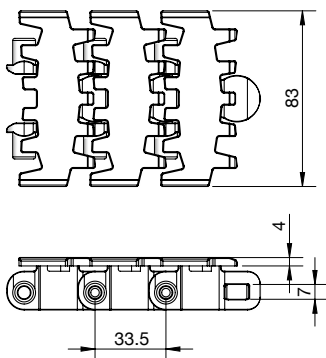
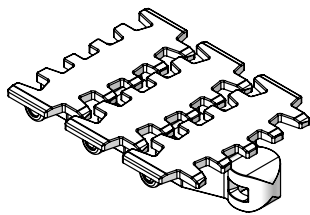

**UOM: 5 Meter / box**

Application: Suitable twist conveyor beam; horizontal and slope < 5° transport of products with accumulation

### Safety Chain FMPC-5V

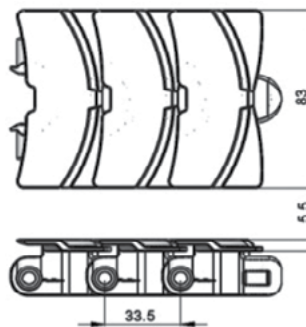
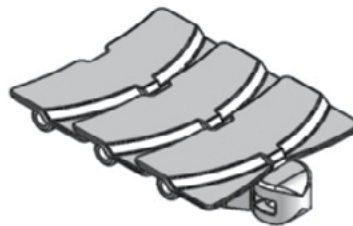

**UOM: 5 Meter / box**

Application: (Safety Chain) Suitable for horizontal and slope < 5° transport of products with accumulation

### Safety Chain Friction Top FMFT-5V-A

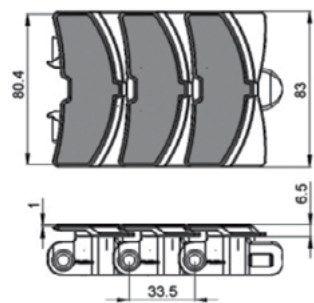

**UOM: 5 Meter / box**

Application: (Safety Chain) Suitable for transport product in slope > 5° but ≤ 30° without accumulation.

**Friction Top Chain FMFT-5**

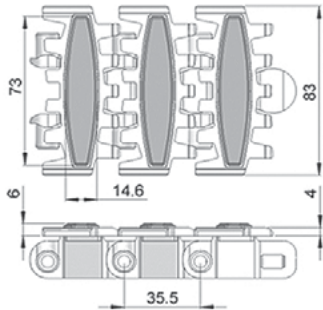
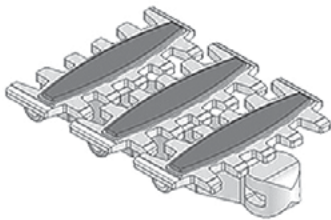

**UOM: 5 Meter / box**

Application: Suitable for transport product in slope > 5° but ≤ 30° without accumulation.

**Friction Top Chain FMFT-5A**

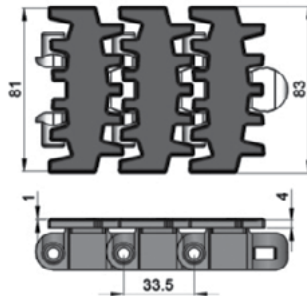
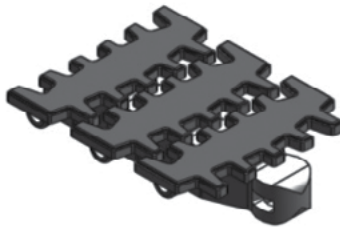

**UOM: 5 Meter / box**

Application: Suitable for transport product in slope > 5° but ≤ 30° without accumulation.

**Wedge Top Chain FMWT-5A**

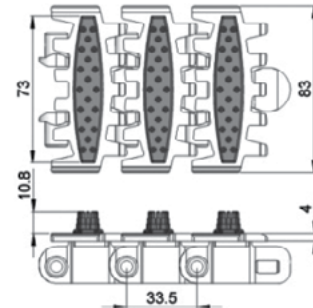
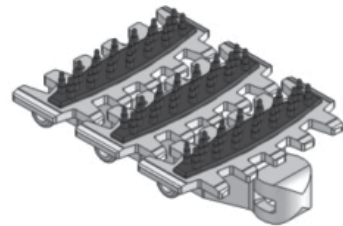

**UOM: 5 Meter / box**

Application: Vertical Wedge transportation of products.

**Wedge Top Chain FMWT-5B**

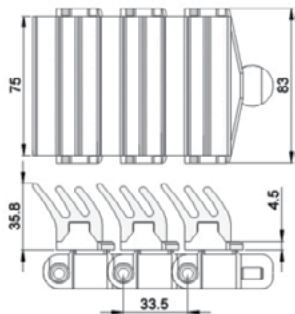
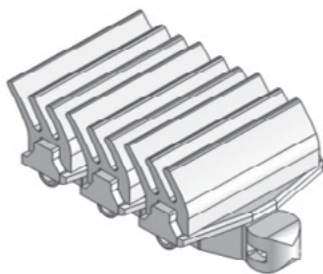

**UOM: 5 Meter / box**

Application: Vertical Wedge transportation of products (Heavy Duty)

**Wedge Top Chain FMWT-5C**

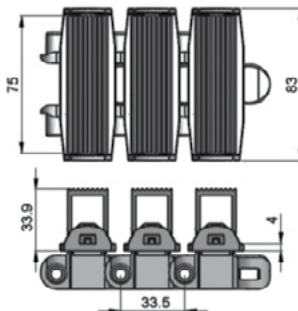
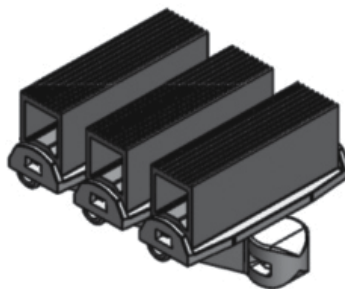

**UOM: 5 Meter / box**

Application: Vertical Wedge transportation of products (Heavy Duty)

**Wedge Top Chain FMWT-5D**

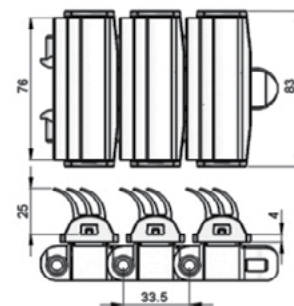
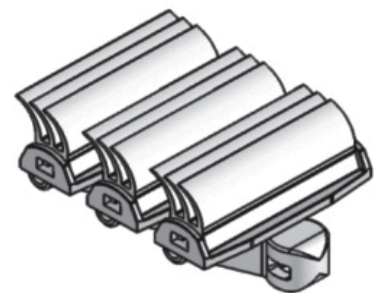

**UOM: 5 Meter / box**

Application: Vertical Wedge transportation of products.

Magnet Top Chain **FMMT-5**

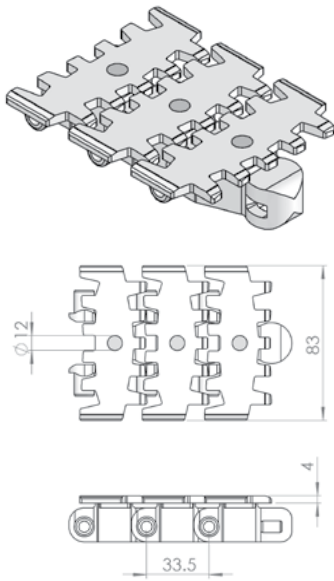

**UOM: 5 Meter / box**  
 Application: Suitable for conveying of ferromagnetic products in slope.

Magnet Top Chain **FMMT-5-L#**

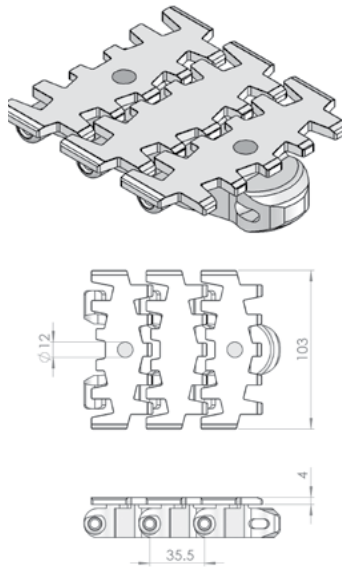

**UOM: 5 Meter / box**  
 Application: Suitable for conveying of ferromagnetic products in slope.

Flocked Chain **FMFK-5**

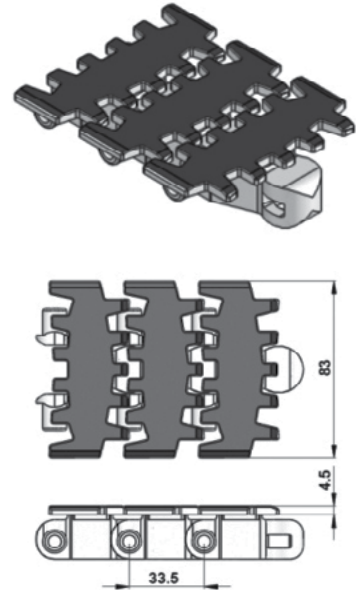

**UOM: 5 Meter / box**  
 Application: Suitable to transport lightweight, fragile and scratch sensitive product.

Hardened Steel Top Chain **FMST-5**

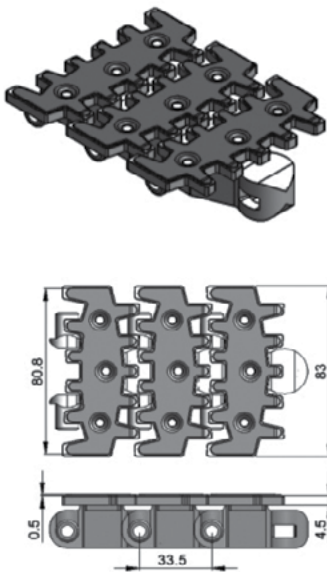

**UOM: 5 Meter / box**  
 Application: Suitable to transport metal products in accumulation.

Stainless Steel Top Chain **FMST-5S**

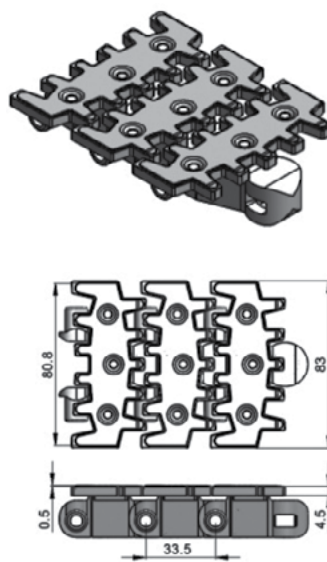

**UOM: 5 Meter / box**  
 Application: Suitable to transport metal products in accumulation.

Universal Chain **FMUC-5**

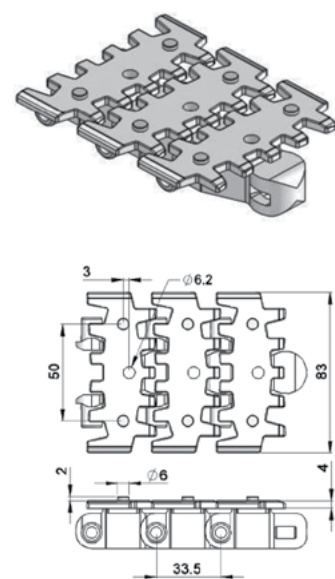

**UOM: 5 Meter / box**  
 Application: Universal Link with M6 Nut, Suitable for attached customer cleat or fixture.



**Roller Top Chain FMRT-5**

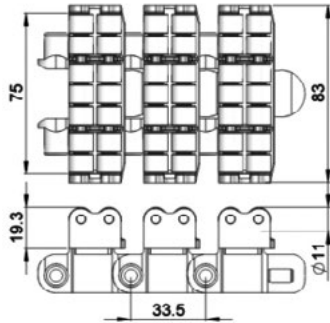
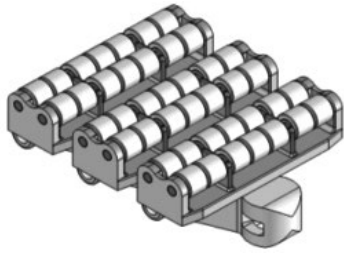

**UOM: 5 Meter / box**

Application: Suitable for accumulation of product with low friction and pressure.

**Roller Cleat Chain FMRC-5A-L#**

# = 1, 2, 3, 4, 5.....20

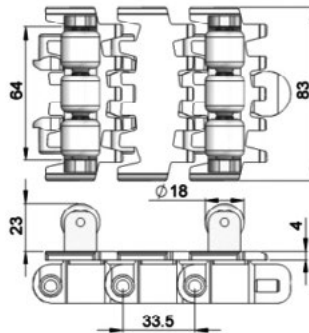
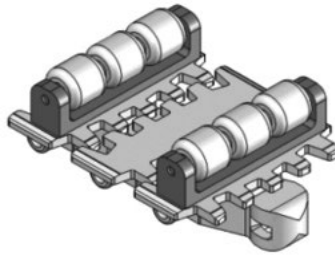

**UOM: 5 Meter / box**

Application: Suitable for vertical transportation of product in slope with no accumulation.

**Roller Cleat Chain FMRC-5B-L#**

# = 1, 2, 3, 4, 5.....20

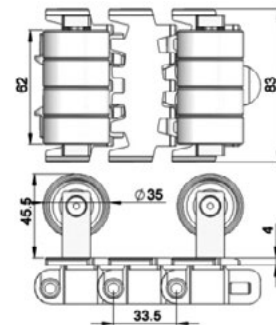
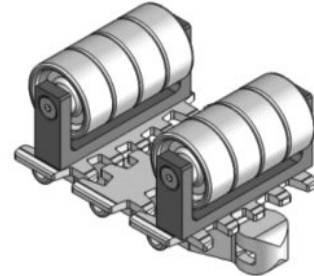

**UOM: 5 Meter / box**

Application: Suitable for vertical transportation of product in slope with no accumulation.

**Cleat Top Chain FMCT-5A17-L#**

# = 1, 2, 3, 4, 5.....20

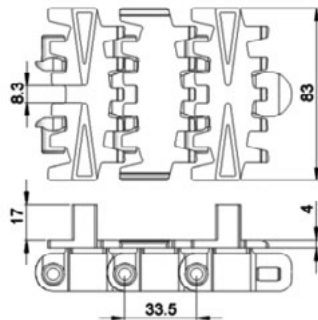
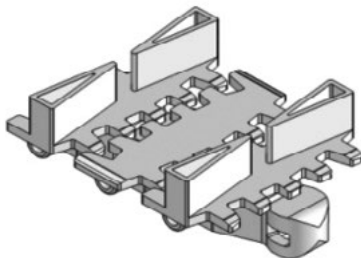

**UOM: 5 Meter / box**

Application: Suitable for vertical transport of product with no accumulation.

**Cleat Top Chain FMCT-5A30-L#**

# = 1, 2, 3, 4, 5.....20

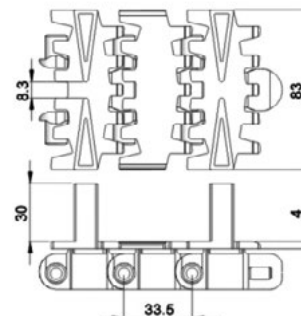
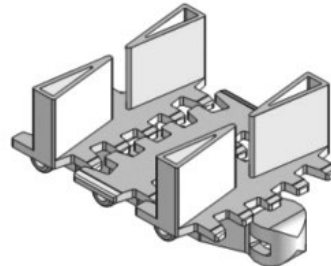

**UOM: 5 Meter / box**

Application: Suitable for vertical transport of product with no accumulation.



# SM SERIES: 85 mm

SM Direct End Drive without Motor (LEFT)  
SMDD-A85-0L

SM Direct End Drive without Motor (RIGHT)  
SMDD-A85-0R

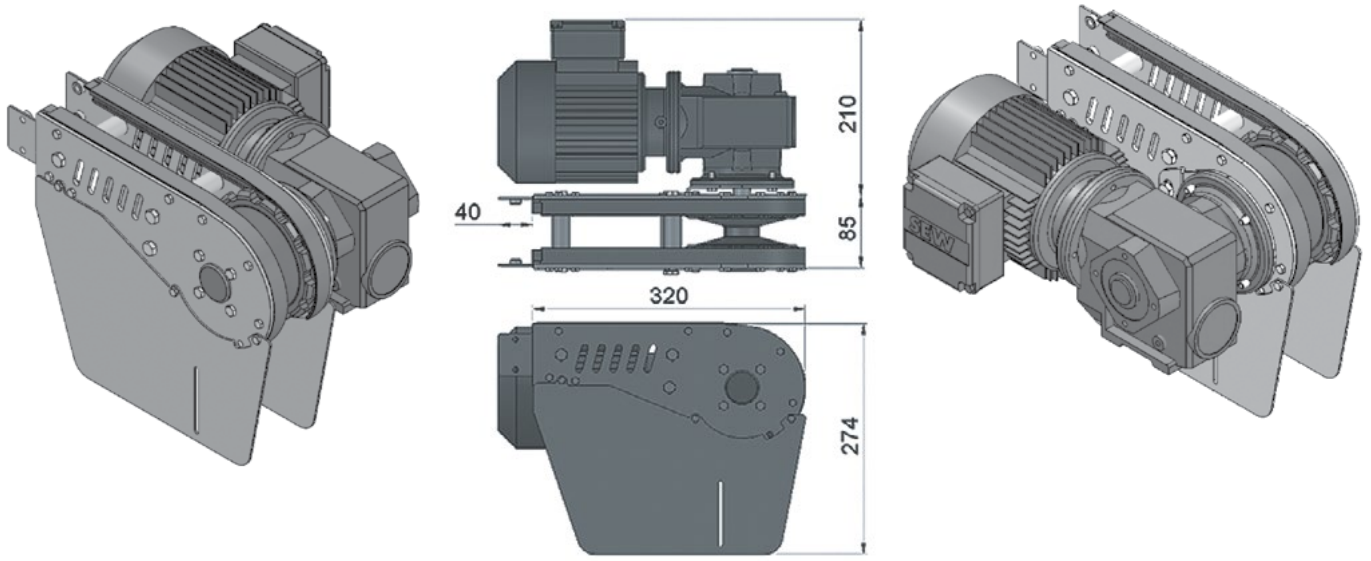

**Max Traction Force: 1250N**

The Direct End Drive Unit is without torque limiter. See page 66-67 for Gearmotor options.

**UOM: pc**

Chain required 2-way: 0.8 meter    Slide rail required 2-way: 0.5 meter

SM Direct End Drive GP without Motor (LEFT)  
SMDD-A85GP-0L

SM Direct End Drive GP without Motor (RIGHT)  
SMDD-A85GP-0R

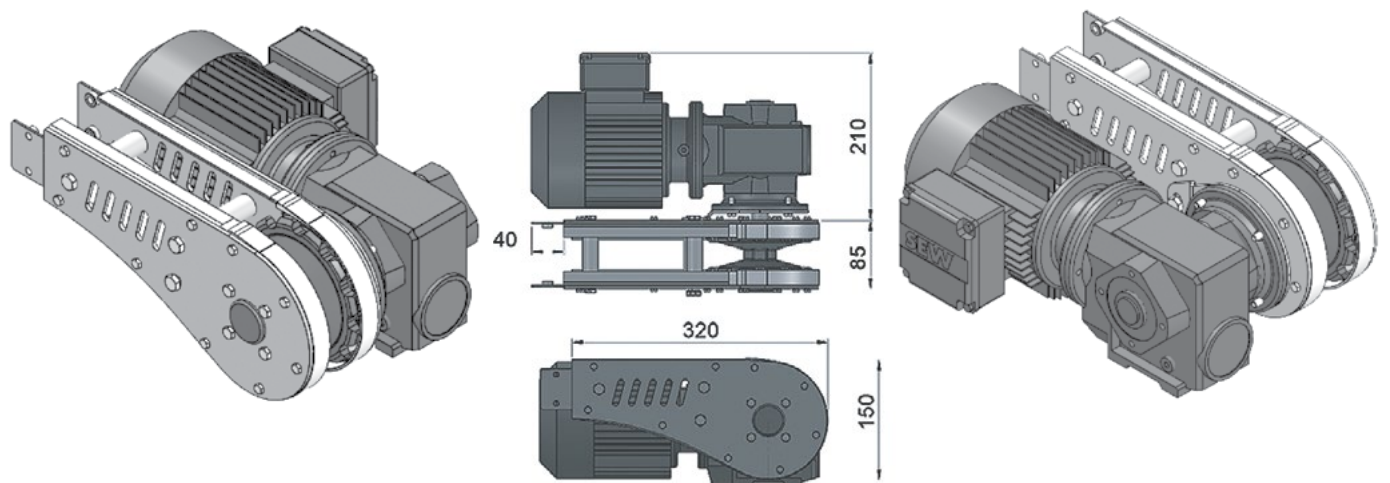

**Max Traction Force: 1250N**

The Direct End Drive Unit is without torque limiter. See page 66-67 for Gearmotor options.

**UOM: pc**

Chain required 2-way: 0.8 meter    Slide rail required 2-way: 0.5 meter

SEW gearmotors are products of SEW Eurodrive

**SM Idler End-A85**

**SMIE-A85**

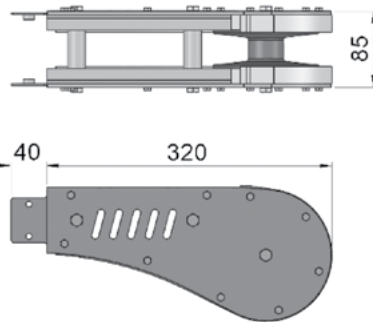
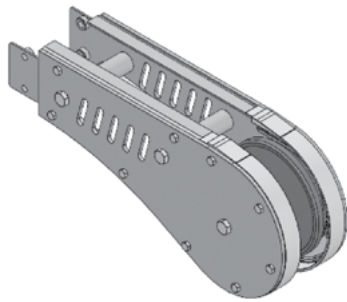

**UOM: pc**  
 Chain required 2-way: 0.8 meter  
 Slide rail required 2-way: 0.5meter

**SM Wheel Bend 180°**

**SMWB-180R160A**

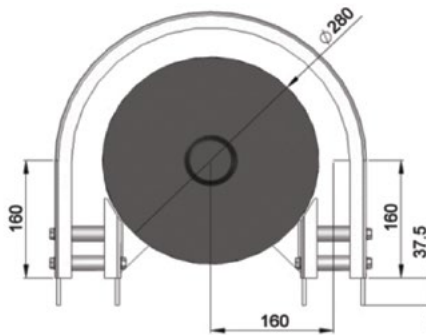
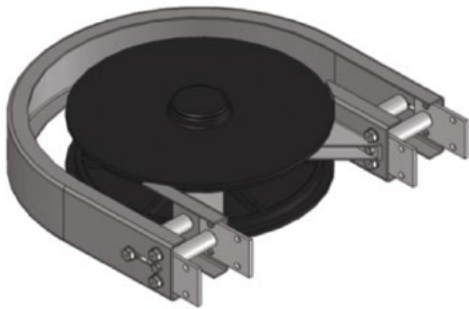

**UOM: pc**  
 Chain required 2-way: 1.4 meter  
 Slide rail required 2-way: 2.8 meter

**SM Wheel Bend 90°**

**SMWB-90R160A**

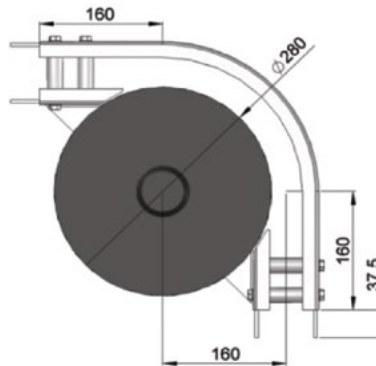

**UOM: pc**  
 Chain required 2-way: 0.9 meter  
 Slide rail required 2-way: 1.7 meter

**SM Wheel Bend 45°**

**SMWB-45R160A**

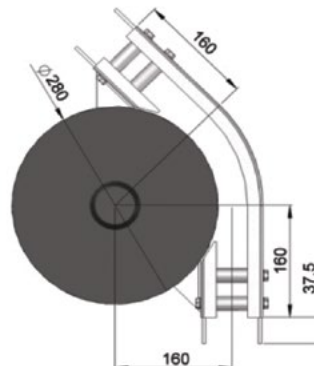
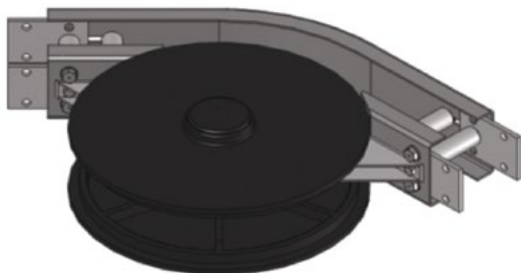

**UOM: pc**  
 Chain required 2-way: 0.6 meter  
 Slide rail required 2-way: 1.2 meter

SM Wheel Bend 5° - 180°

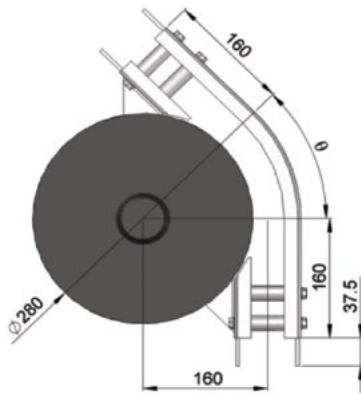

Example for SM Wheel Bend Ordering

- Wheel bend,  $\theta^\circ \pm 1^\circ$

If an angle of 65° is needed for wheel bend, the ordering part number is

**SMWB-65R160**

The outer bend is assembled using connecting strip (SACS-50x75). Angle of  $\theta^\circ$  must be indicated when ordering.

SM Horizontal Plain Bend 30°

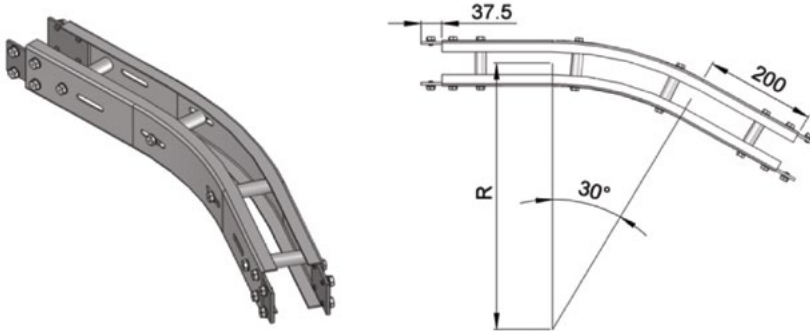

Horizontal plain bend,  $30^\circ \pm 1^\circ$

- R = 500 ± 10 mm      **SMHB-30R500**
- R = 700 ± 10 mm      **SMHB-30R700**

UOM: pc

Chain required 2-way (500, 700): 1.4, 1.6 meter  
Slide rail required 2-way (500, 700): 2.8, 3.2 meter

SM Horizontal Plain Bend 45°

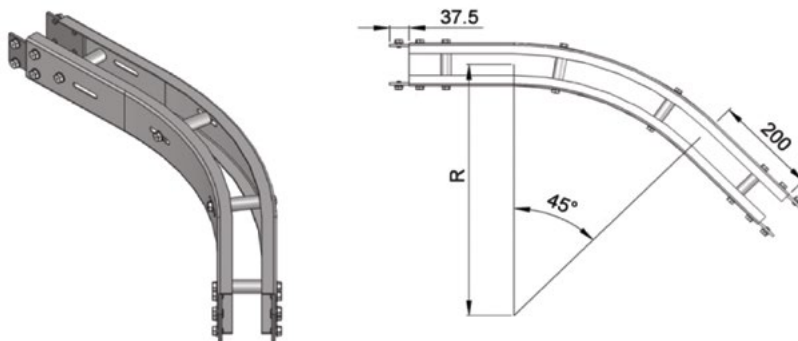

Horizontal plain bend,  $45^\circ \pm 1^\circ$

- R = 500 ± 10 mm      **SMHB-45R500**
- R = 700 ± 10 mm      **SMHB-45R700**

UOM: pc

Chain required 2-way (500, 700): 1.6, 1.9 meter  
Slide rail required 2-way (500, 700): 2.9, 3.3 meter

SM Horizontal Plain Bend 90°

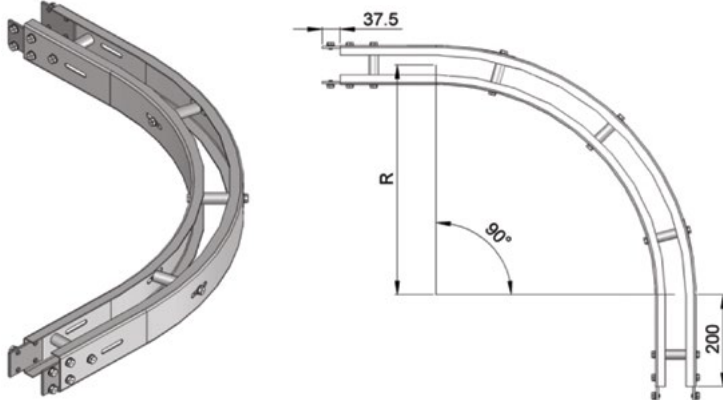

Horizontal plain bend,  $90^\circ \pm 1^\circ$

- R = 500 ± 10 mm      **SMHB-90R500**
- R = 700 ± 10 mm      **SMHB-90R700**

UOM: pc

Chain required 2-way (500, 700): 2.4, 3.0 meter  
Slide rail required 2-way (500, 700): 4.8, 6.0 meter

**SM Horizontal Plain Bend 5-180°**

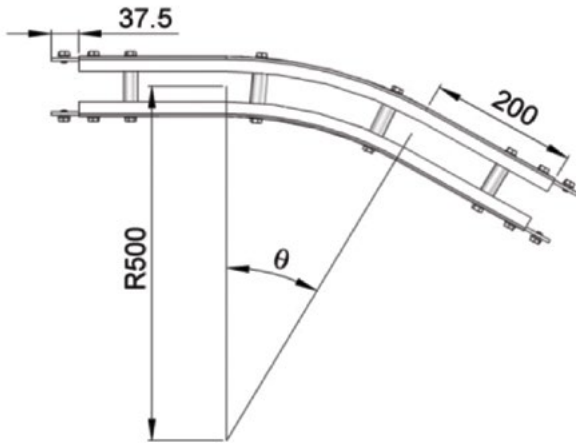

**Example for SM Horizontal Plain Bend Ordering**

**Horizontal plain bend,  $\theta^\circ \pm 1^\circ$**

R = 500 ± 10 mm      **SMHB-ØR500**

R = 700 ± 10 mm      **SMHB-ØR700**

If an angle of 70° is needed for radius R500 horizontal plain bend, the ordering part number is

**SMHB-70R500**

**UOM: pc**

Chain required 2-way (500, 700): meter (Variable to angle)

Slide rail required 2-way (500, 700): meter (Variable to angle)

**SM Vertical Bend 5°**

**SMVB-5R400**

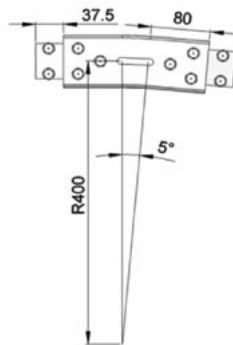
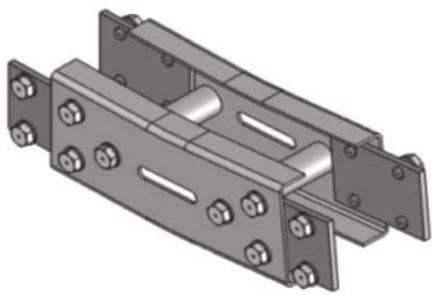

**UOM: pc**

Chain required 2-way: 0.4 meter

Slide rail required 2-way: 0.8 meter

**SM Vertical Bend 15°**

**SMVB-15R400**

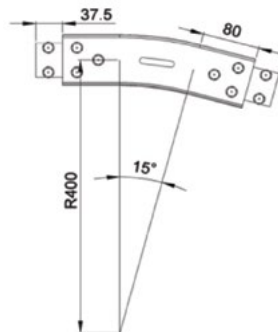
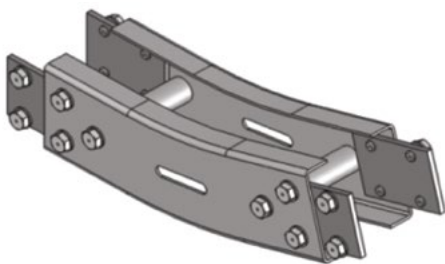

**UOM: pc**

Chain required 2-way: 0.6 meter

Slide rail required 2-way: 1.1 meter

**SM Vertical Bend 30°**

**SMVB-30R400**

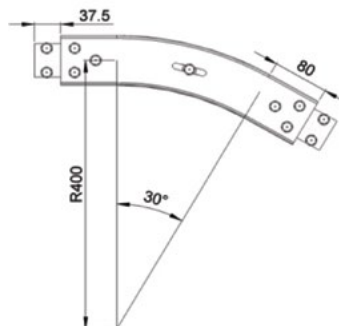
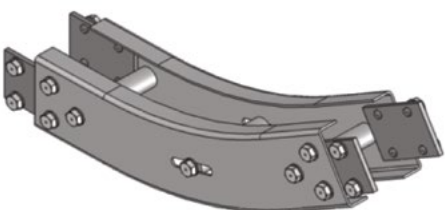

**UOM: pc**

Chain required 2-way: 0.8 meter

Slide rail required 2-way: 1.5 meter

SM Vertical Bend 5° - 90°

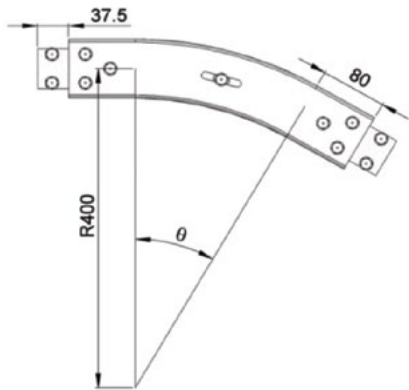

**Example for SM Vertical Bend Ordering**

- Vertical bend,  $\theta^\circ \pm 1^\circ$

If an angle of 25° is needed for vertical bend, the ordering part number is

**SMVB-25R400**

The outer bend is assembled using connecting strip (SACS-50x75). Angle of  $\theta^\circ$  must be indicated when ordering.

SM Horizontal beam support bracket – Stainless Steel

SAHBS-90M

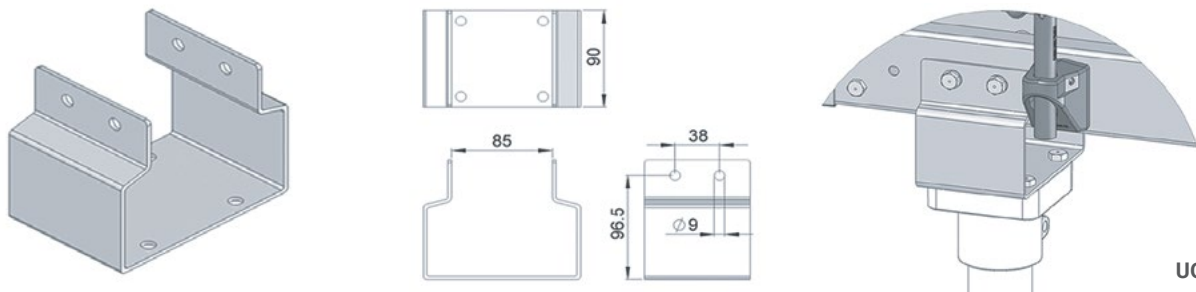

UOM: pc

SM Adjustable Angle Beam Support Bracket

SAHBS-90M-A35

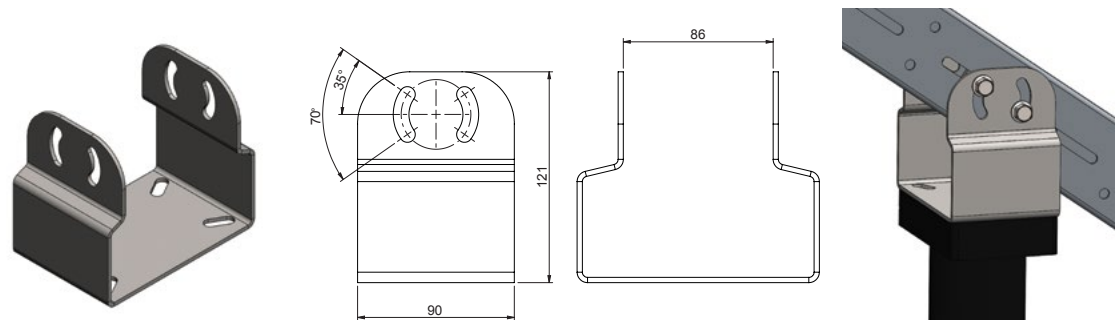

UOM: pc

SM Horizontal Tripod Support

SBSM-HXXXX, where XXXX = H Height (mm)

SM Adjustable Angle Tripod Support

SBSM-A-HXXXX, where XXXX = H Height (mm)

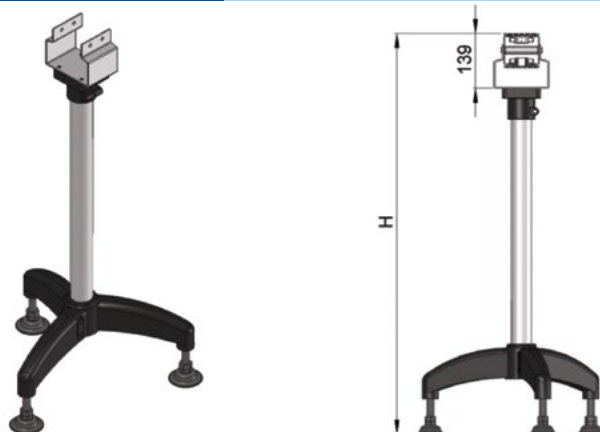

UOM: pc  
Includes Beam Support Bracket



## SC Series

### SC Series:

**Beam Width:** 105 mm

**Product Width:** Refer to Guide Rail Assembly

### Accessories Needed:

**Slide Rail Required:** FASR-25 OR FASR-25U

**Slide Rail Color:** White or Natural Color

**Slide Rail Material:** HDPE OR UHMW

**Slide Rail Rivet:** FASLS-M5

Connecting strip is used to connect 2 beams.

**Connecting Strip:** SACS-50x70

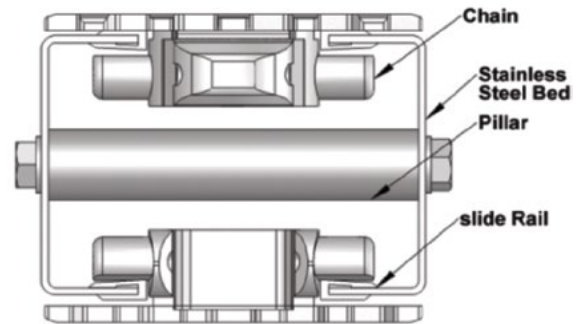

### Conveyor Beam SCCB-LXXXX

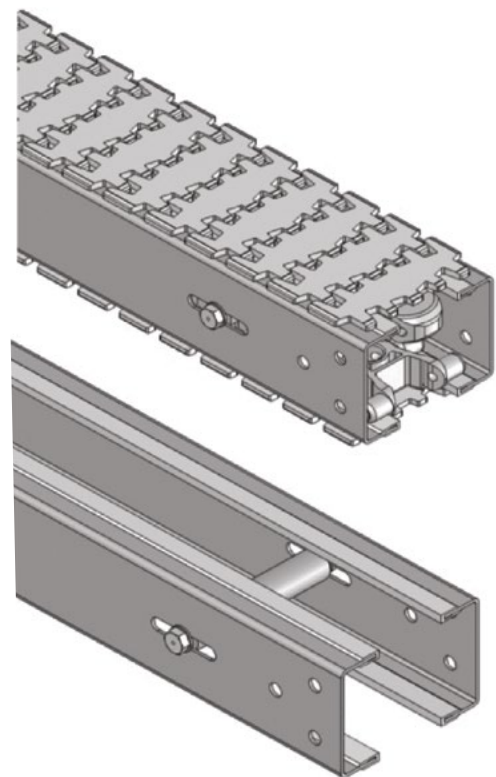
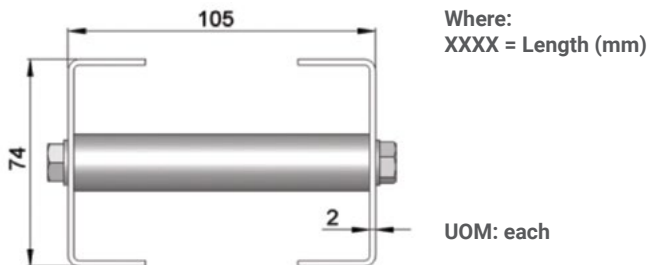

### Chain Connecting Module SCCC-160

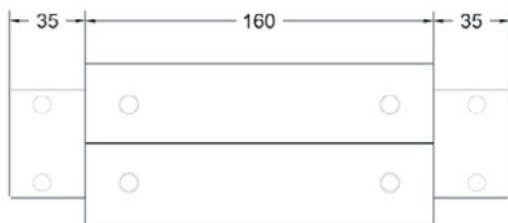

### Connecting Strip – Stainless Steel

SACS-50x70

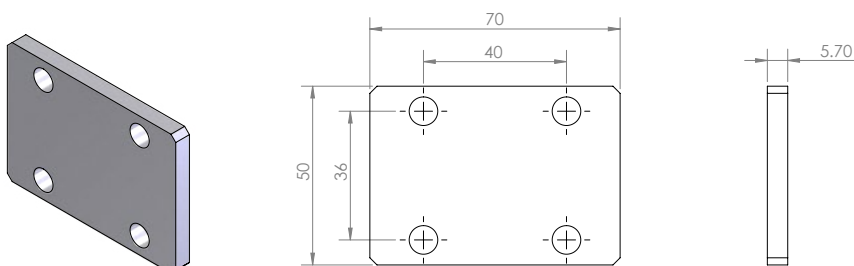



Idler End

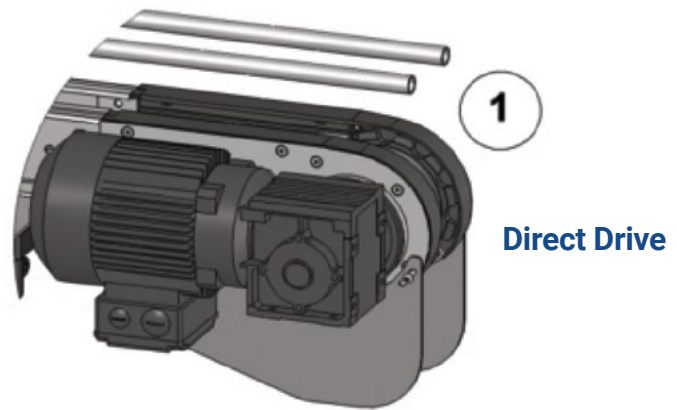

Direct Drive



Horizontal  
Beam Support



Tripod  
Structure

### Chain Common Data

**Packaging:** 5 m per box

**Pitch:** 35.5 mm

**Width:** 103 mm

Tensile Strength at 20°C: 6000N

**Color:** White & Black (Conductive)

### Material:

**Chain:** White Acetal / POM

**Pivot:** Polyamide

**Pivot Pin:** Stainless Steel

**Insert (Wedge & Friction):** TPE Grey

### Example for FCCT-5A17-L#

# = 1 cleated top chain with alternate of # link of plain chain

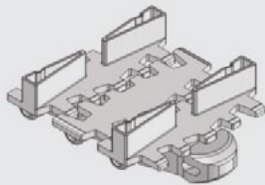

The above chain is FCCT-5A17-L1, 1 link cleated top chain with alternate of 1 link of plain chain.

**Note:** # = 1, 2, 3, 4, 5.....20

### Standard Plain Chain FCPC-5

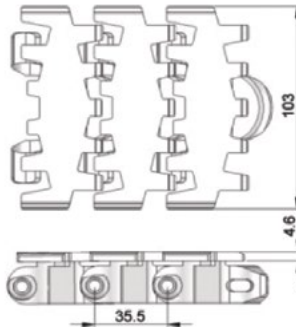
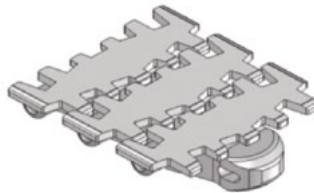

**UOM:** 5 Meter / box

Application: Suitable for horizontal and slope < 5° transport of products with accumulation.

### Conductive Chain FCPC-5CD

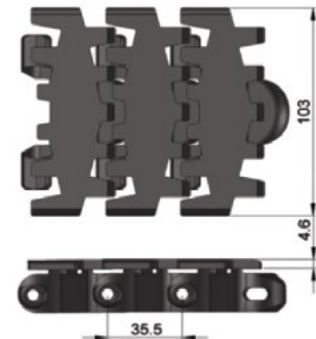
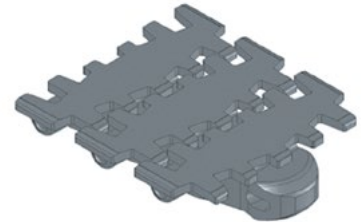

**UOM:** 5 Meter / box

Application: Suitable for transport of static sensitive product.

### Cleat Top Chain FCCT-5A30-L#

# = 1, 2, 3, 4, 5.....20

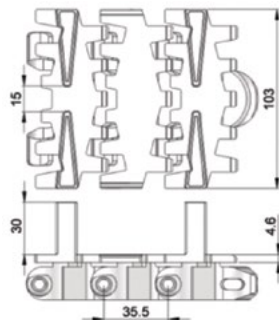
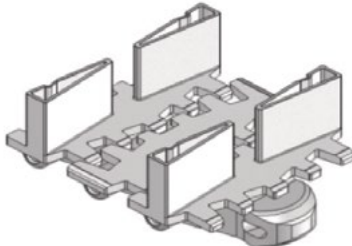

**UOM:** 5 Meter / box

Application: Suitable for vertical transport of product with no accumulation.

### Cleat Top Chain FCCT-5A17-L#

# = 1, 2, 3, 4, 5.....20

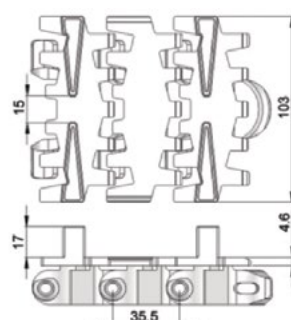
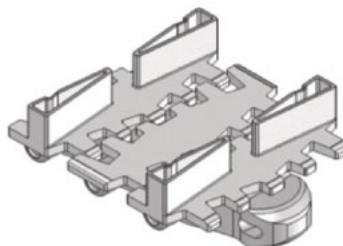

**UOM:** 5 Meter / box

Application: Suitable for vertical transport of product with no accumulation.

### Roller Top Chain FCRT-5

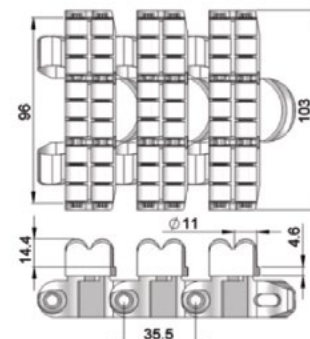
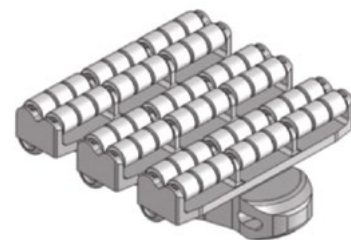

**UOM:** 5 Meter / box

Application: Suitable for accumulation of product with low friction and pressure.

Roller Cleat Chain **FCRC-5A-L#**

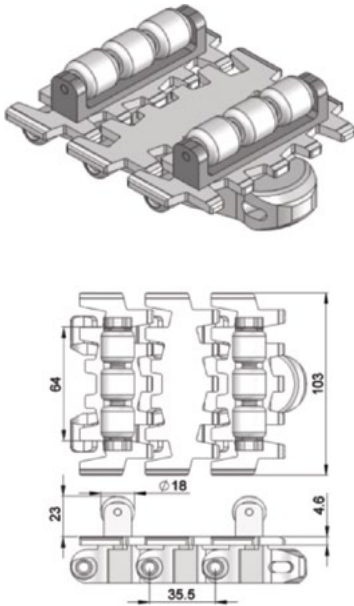

**UOM: 5 Meter / box**  
 Application: Suitable for vertical transportation of product in slope with no accumulation.

Roller Cleat Chain **FCRC-5B-L#**

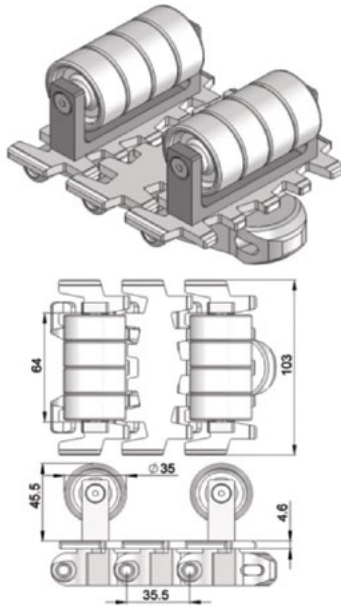

**UOM: 5 Meter / box**  
 Application: Suitable for vertical transportation of product in slope with no accumulation.

Friction Top Chain **FCFT-5**

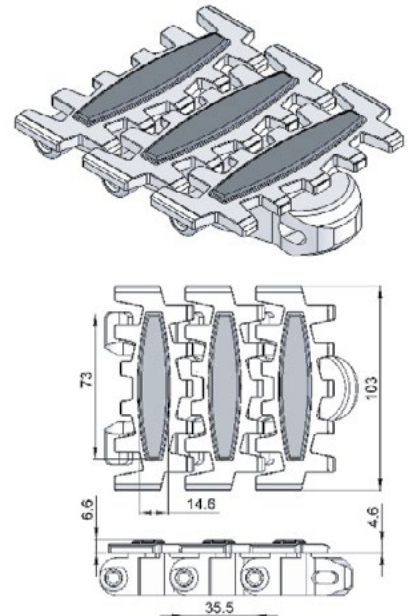

**UOM: 5 Meter / box**  
 Application: Suitable for transport product in slope > 5° but ≤ 30° without accumulation.

Friction Top Chain **FCFT-5A**

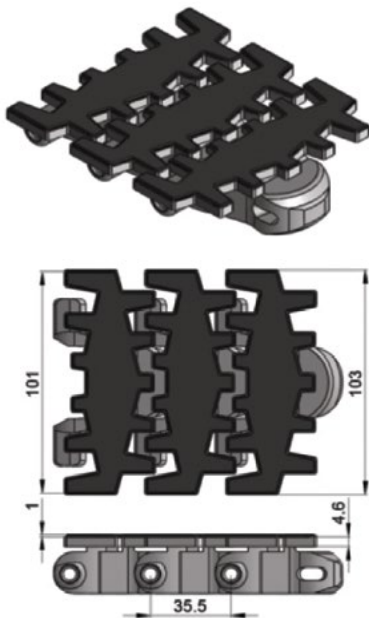

**UOM: 5 Meter / box**  
 Application: Suitable for transport product in slope > 5° but ≤ 30° without accumulation.

Friction Top Chain **FCFT-5B**

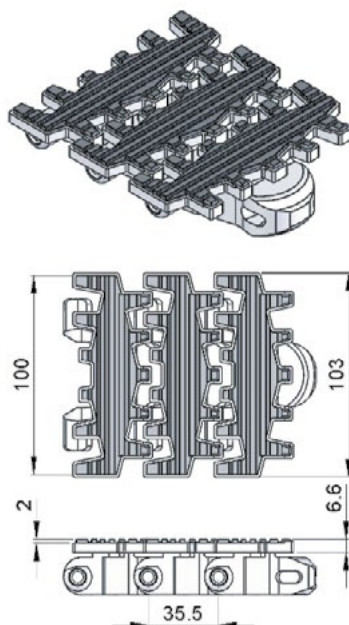

**UOM: 5 Meter / box**  
 Application: Suitable for transport product in slope > 5° but ≤ 40° without accumulation.

Friction Top Chain **FCFT-5C**

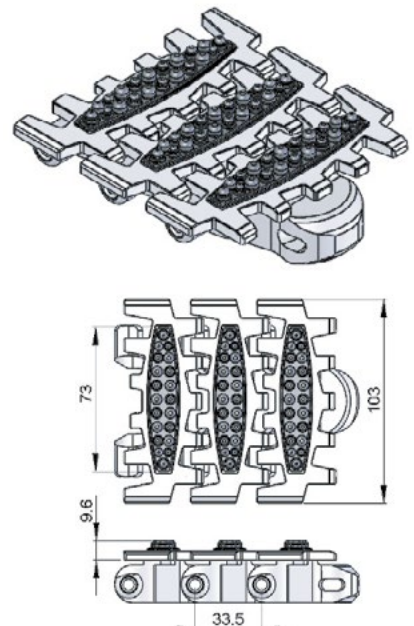

**UOM: 5 Meter / box**  
 Application: Suitable for transport product in slope > 5° but ≤ 35° without accumulation.



Hardened Steel Top Chain FCST-5

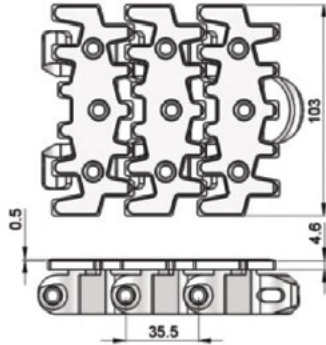
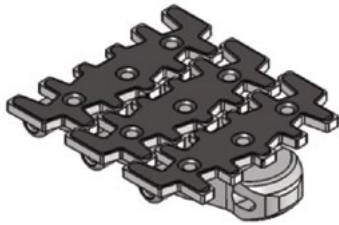

**UOM: 5 Meter / box**  
 Application: Suitable to transport metal products in accumulation.

Stainless Steel Top Chain FCST-5S

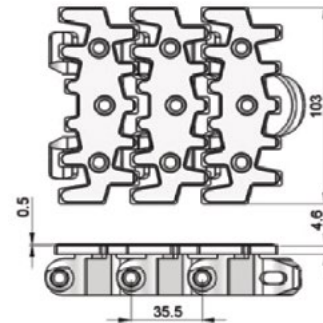
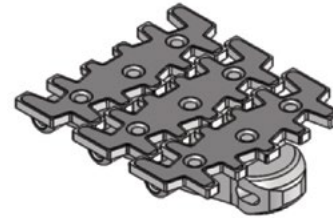

**UOM: 5 Meter / box**  
 Application: Suitable to transport metal products in accumulation.

Flocked Chain FCFK-5

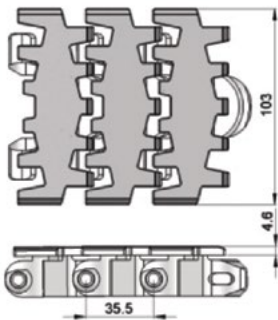
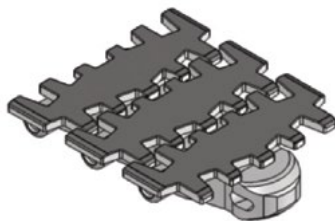

**UOM: 5 Meter / box**  
 Application: Suitable to transport lightweight, fragile and scratch sensitive product.

Safety Chain FCPC-5V

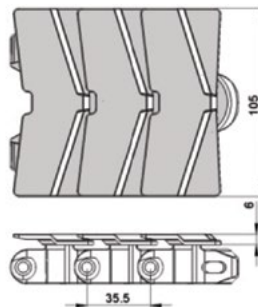
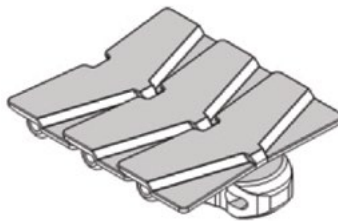

**UOM: 5 Meter / box**  
 Application: (Safety Chain) Suitable for horizontal and slope < 5° transport of products with accumulation.

Twist Chain FCPC-5M

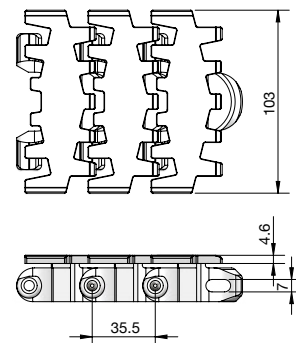
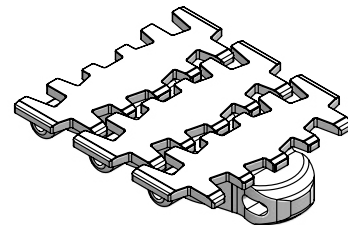

**UOM: 5 Meter / box**  
 Application: Suitable twist conveyor beam; horizontal and slope < 5° transport of products with accumulation



SC Direct End Drive without Motor (LEFT)  
SCDD-A105-0L

SC Direct End Drive without Motor (LEFT)  
SCDD-A105-0R

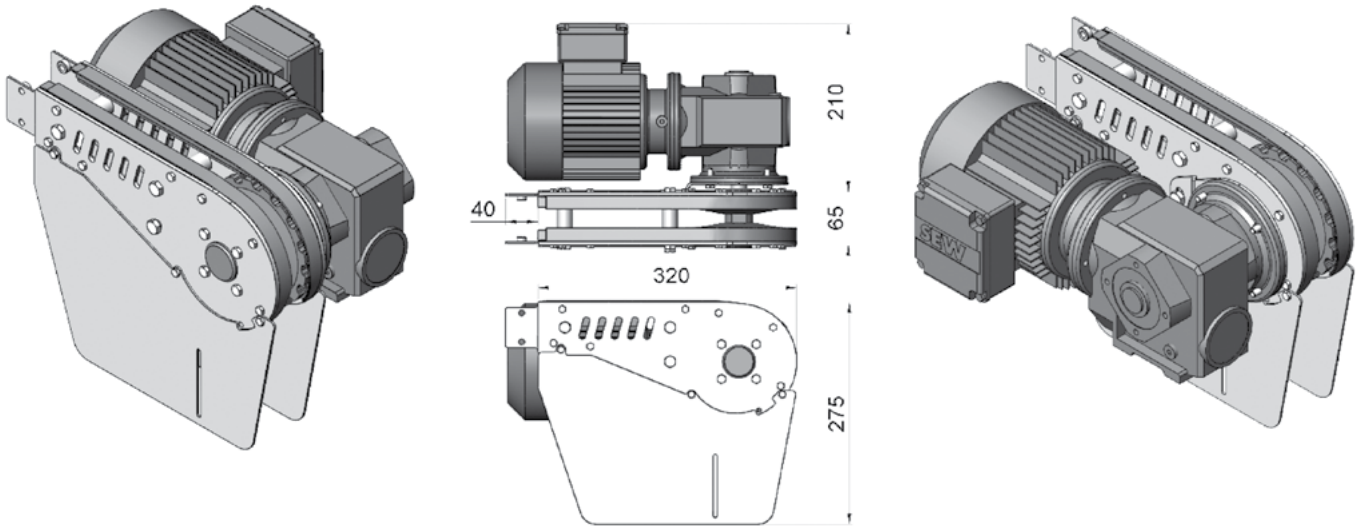

**Max Traction Force: 1250N**

The Direct End Drive Unit is without torque limiter. See page 66-67 for Gearmotor options.

**UOM: pc**

Chain required 2-way: 0.8 meter    Slide rail required 2-way: 0.5 meter

SC Idler End-A105

SCIE-A105

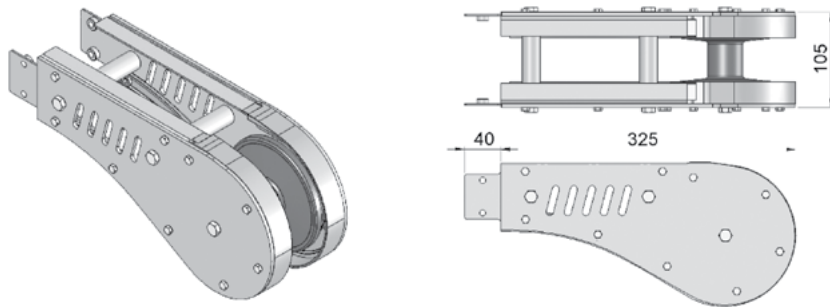

**UOM: pc**

Chain required 2-way: 0.8 meter  
Slide rail required 2-way: 0.5meter

SEW gearmotors are products of SEW Eurodrive

**SC Wheel Bend 180°**

SCWB-180R170A

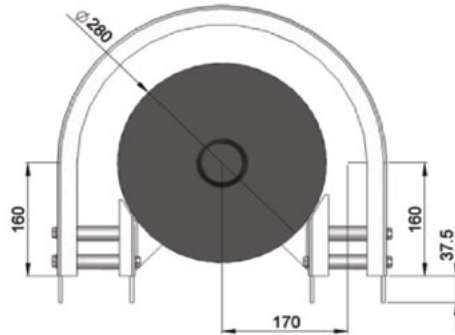
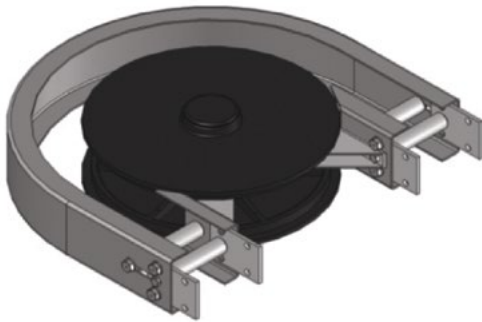

**UOM: pc**  
Chain required 2-way: 1.4 meter  
Slide rail required 2-way: 2.8 meter

**SC Wheel Bend 90°**

SCWB-90R170A

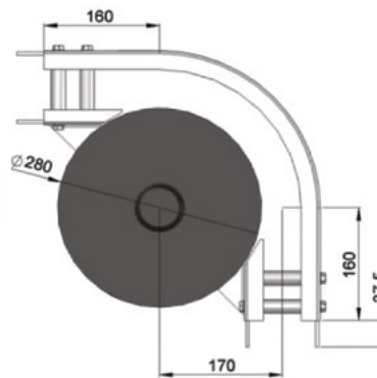

**UOM: pc**  
Chain required 2-way: 0.9 meter  
Slide rail required 2-way: 1.7 meter

**SC Wheel Bend 45°**

SCWB-45R170A

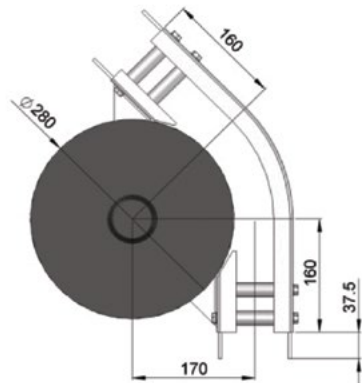
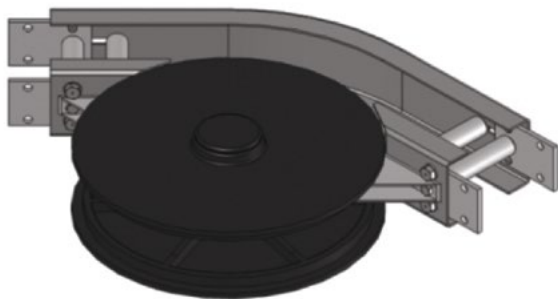

**UOM: pc**  
Chain required 2-way: 0.6 meter  
Slide rail required 2-way: 1.2 meter

**SC Wheel Bend 5° - 180°**

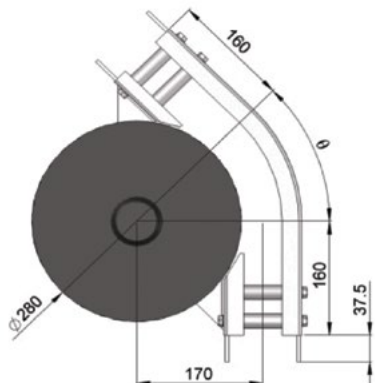

**Example for SC Wheel Bend Ordering**

- Wheel bend,  $\emptyset^\circ \pm 1^\circ$

If an angle of 65° is needed for wheel bend, the ordering part number is

**SCWB-65R170**

The outer bend is assembled using connecting strip (SACS-50x75). Angle of  $\emptyset^\circ$  must be indicated when ordering.

SC Horizontal Plain Bend 30°

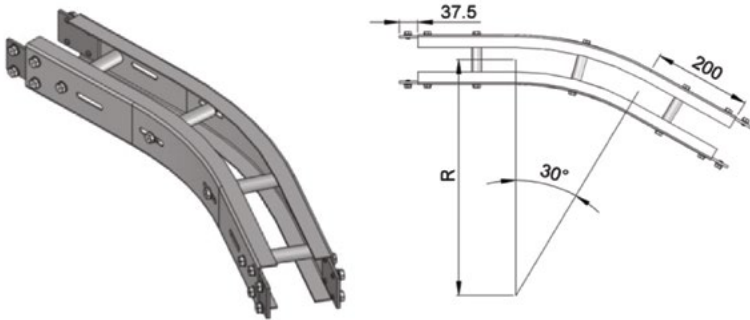

Horizontal plain bend, 30° ± 1°

- R = 500 ± 10 mm      **SCHB-30R500**
- R = 700 ± 10 mm      **SCHB-30R700**

UOM: pc

Chain required 2-way (500, 700): 1.4, 1.6 meter  
 Slide rail required 2-way (500, 700): 2.8, 3.2 meter

SC Horizontal Plain Bend 45°

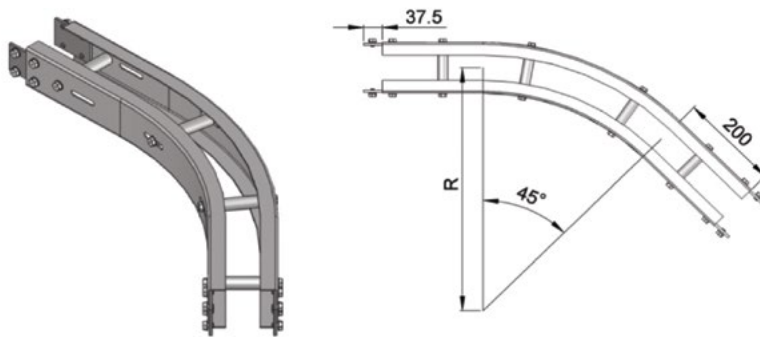

Horizontal plain bend, 45° ± 1°

- R = 500 ± 10 mm      **SCHB-45R500**
- R = 700 ± 10 mm      **SCHB-45R700**

UOM: pc

Chain required 2-way (500, 700): 1.6, 1.9 meter  
 Slide rail required 2-way (500, 700): 2.9, 3.3 meter

SC Horizontal Plain Bend 90°

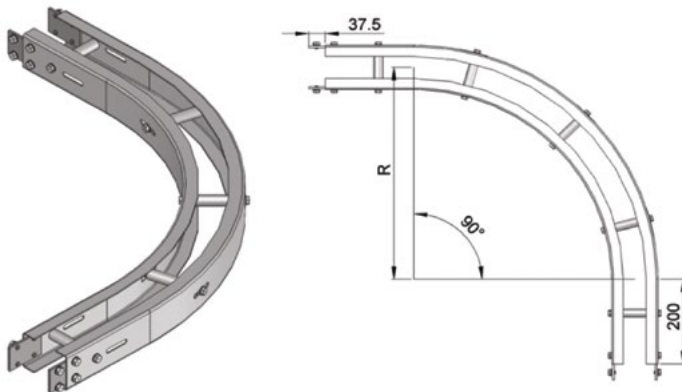

Horizontal plain bend, 90° ± 1°

- R = 500 ± 10 mm      **SCHB-90R500**
- R = 700 ± 10 mm      **SCHB-90R700**

UOM: pc

Chain required 2-way (500, 700): 2.4, 3.0 meter  
 Slide rail required 2-way (500, 700): 4.8, 6.0 meter

SC Horizontal Plain Bend 5-180°

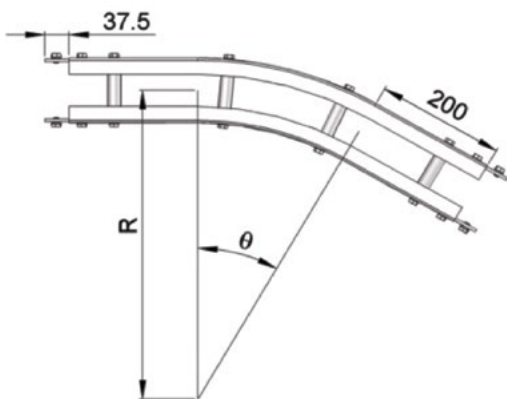

Example for SC Horizontal Plain Bend Ordering

Horizontal plain bend, 0° ± 1°

- R = 500 ± 10 mm      **SCHB-0R500**
- R = 700 ± 10 mm      **SCHB-0R700**

If an angle of 70° is needed for radius R500 horizontal plain bend, the ordering part number is

**SCHB-70R500**

UOM: pc

Chain required 2-way (500, 700): meter (Variable to angle)  
 Slide rail required 2-way (500, 700): meter (Variable to angle)

**SC Vertical Bend 5°**

SCVB-5R400

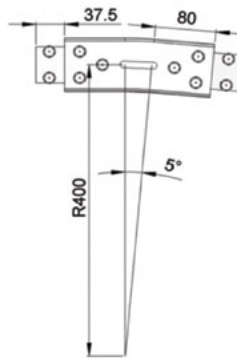
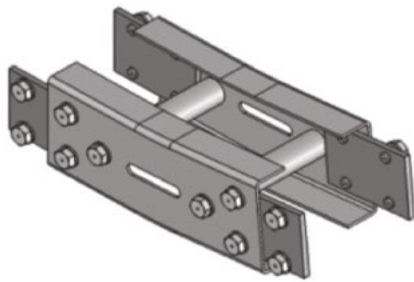

**UOM: pc**  
 Chain required 2-way: 0.4 meter  
 Slide rail required 2-way: 0.8 meter

**SC Vertical Bend 15°**

SCVB-15R400

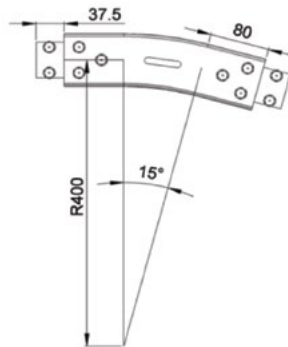
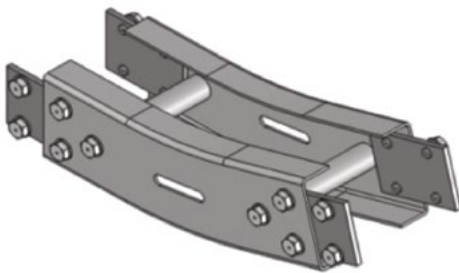

**UOM: pc**  
 Chain required 2-way: 0.6 meter  
 Slide rail required 2-way: 1.1 meter

**SC Vertical Bend 30°**

SCVB-30R400

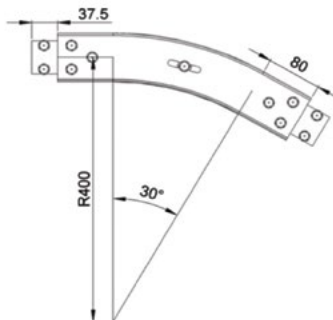
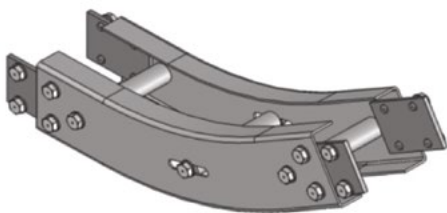

**UOM: pc**  
 Chain required 2-way: 0.8 meter  
 Slide rail required 2-way: 1.5 meter

**SC Vertical Bend 5° - 90°**

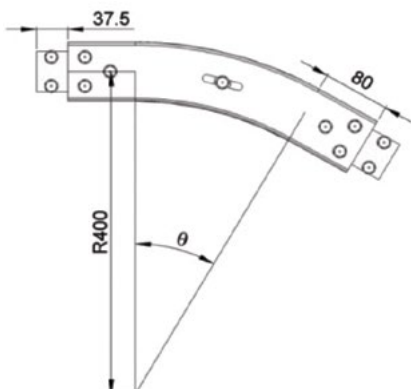

**Example for SC Vertical Bend Ordering**

- Vertical bend,  $\theta^\circ \pm 1^\circ$

If an angle of 25° is needed for vertical bend, the ordering part number is

**SCVB-25R400**

*The outer bend is assembled using connecting strip (SACS-50x75). Angle of  $\theta^\circ$  must be indicated when ordering.*

SC Horizontal beam support bracket – Stainless Steel

SAHBS-90C

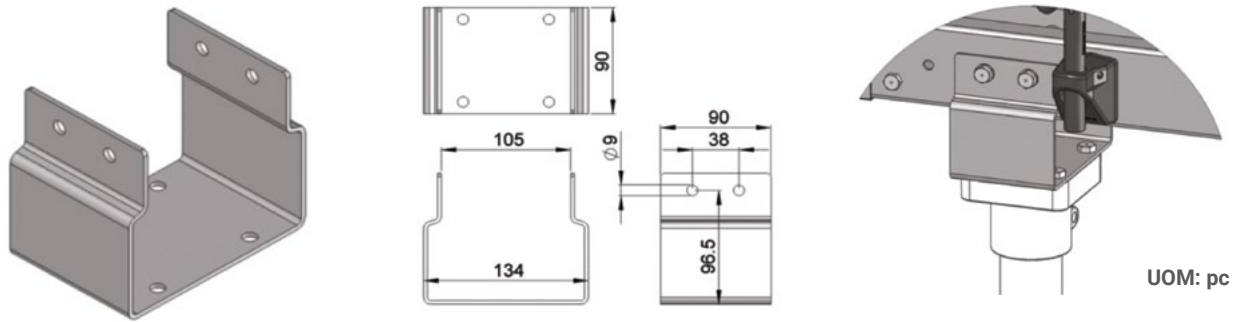

SC Adjustable Angle Beam Support Bracket

SAHBS-90C-A35

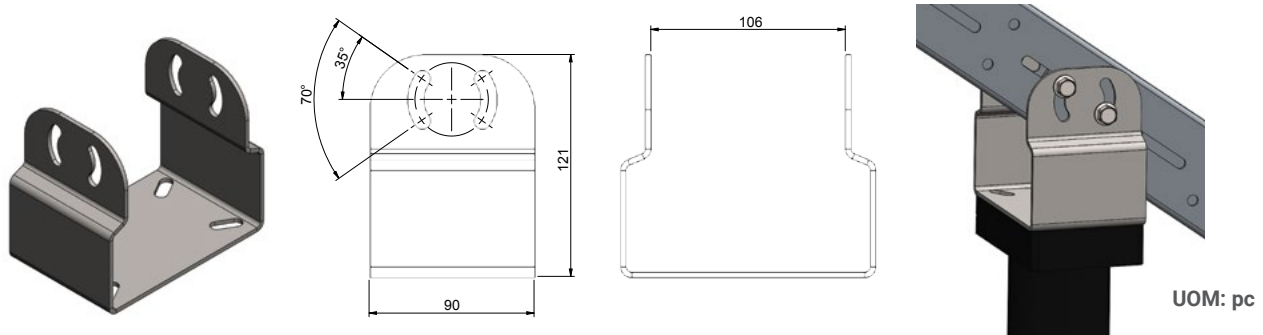

SC Adjustable Angle Tripod Support

SBSC-HXXXX, where XXXX = H Height (mm)

SC Horizontal Tripod Support

SBSC-A-HXXXX, where XXXX = H Height (mm)

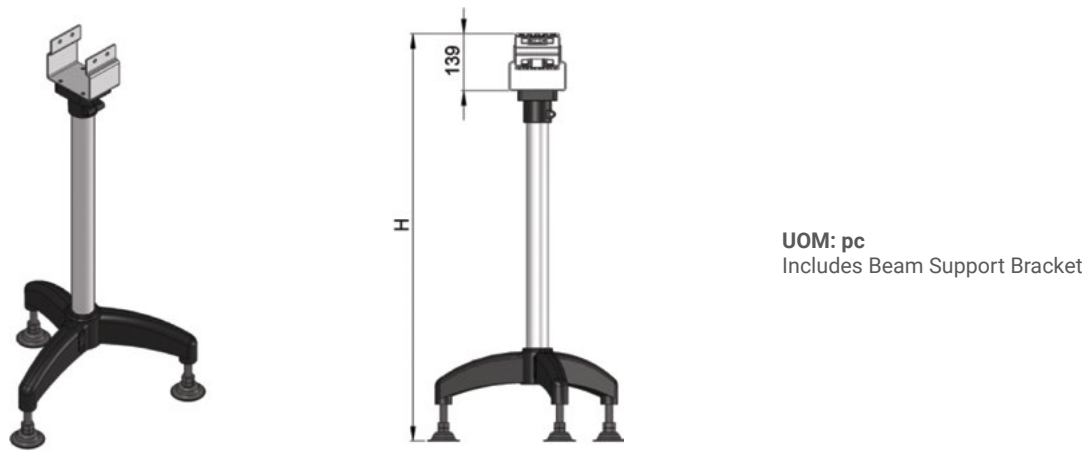



## SU Series

### SU Series:

**Beam Width:** 179 mm

**Product Width:** Refer to Guide Rail Assembly

### Accessories Needed:

**Slide Rail Required:** FASR-25, FASR-25U, FASR-25X

**Slide Rail Color:** White or Natural Color

**Slide Rail Material:** HDPE, UHMWPE or Special PE

**Slide Rail Rivet:** FASLS-M5

Connecting strip is used to connect two beams.

**Connecting Strip:** SACS-50x70

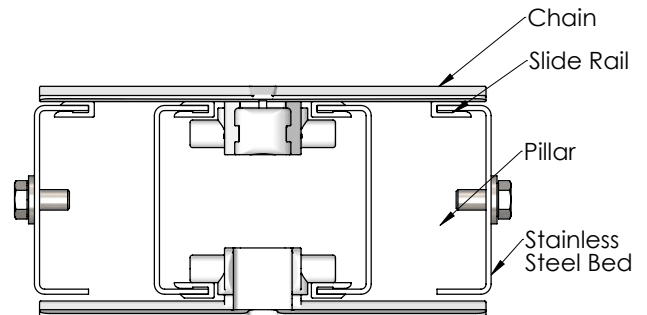

### Conveyor Beam SUCB-LXXXX

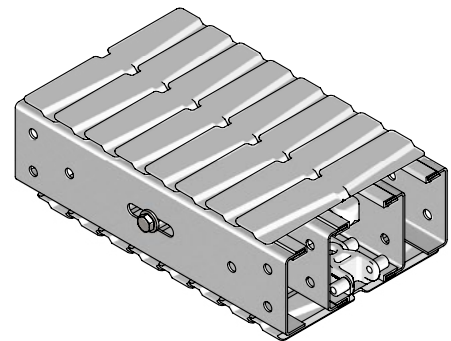
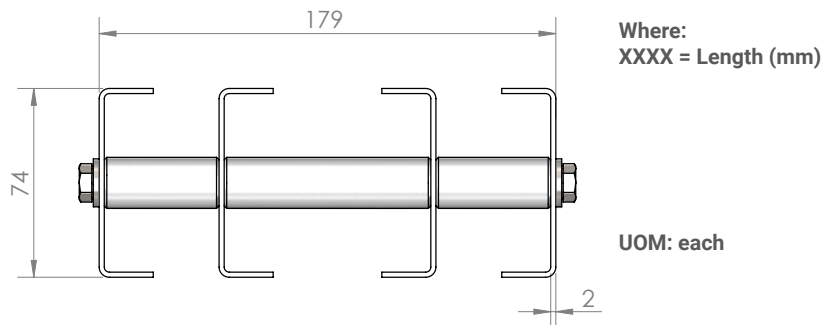

### Chain Connecting Module SUCC-300

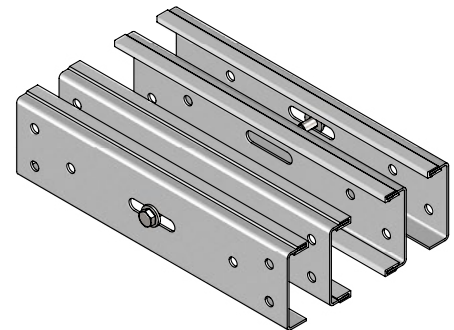
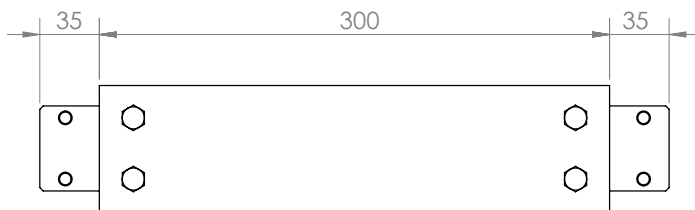

### Connecting Strip – Stainless Steel

SACS-50x70

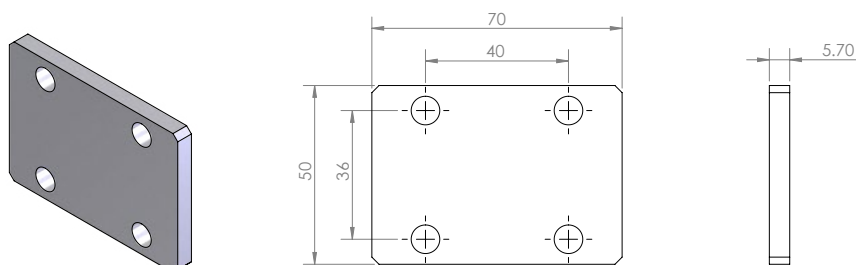

UOM: pc

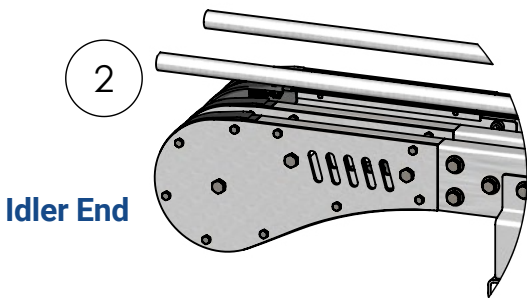
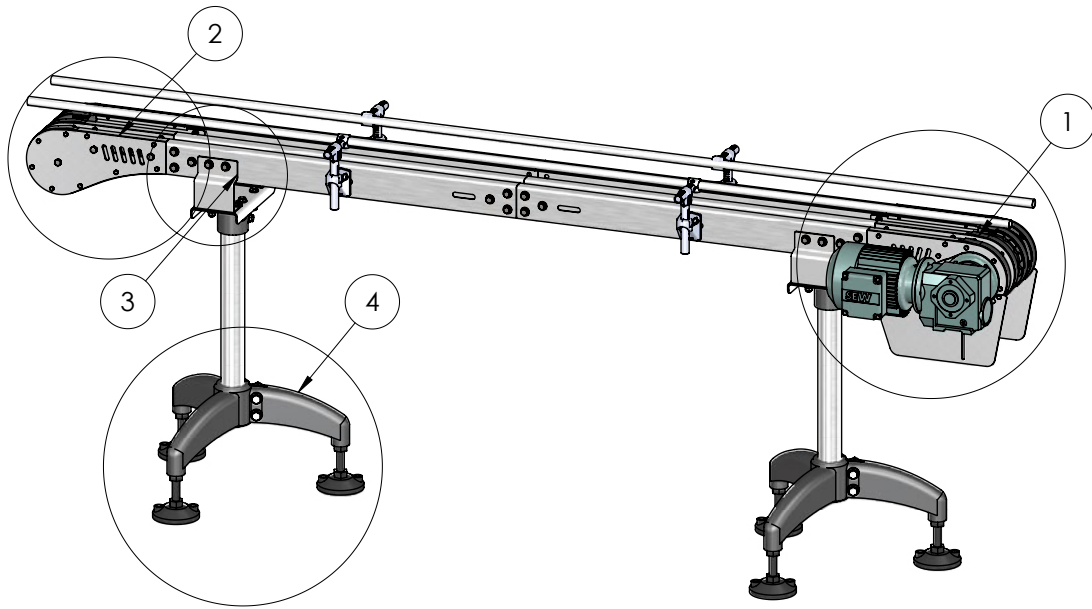

**Idler End**

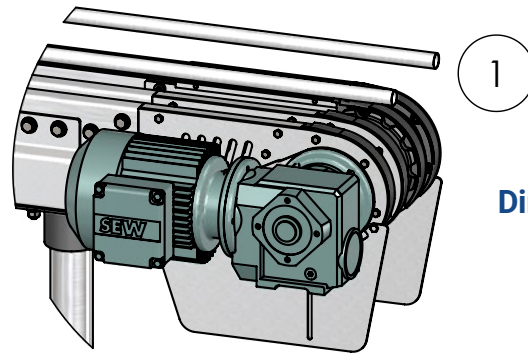

**Direct Drive**

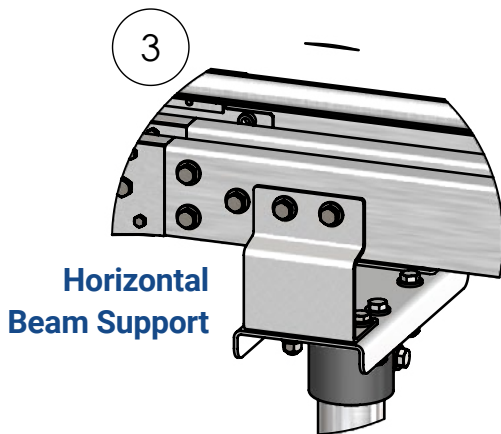

**Horizontal  
Beam Support**

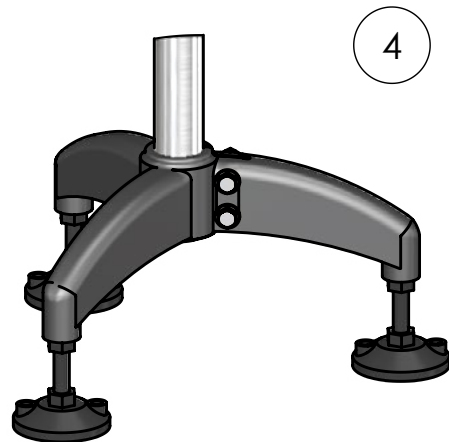

**Tripod  
Structure**

### Chain Common Data

**Packaging:** 5 m per box

**Pitch:** 33.5 mm

**Width:** 175 mm

**Tensile Strength at 20°C:** 6000N

**Color:** White

### Material:

**Chain:** White Acetal / POM

**Pivot:** Polyamide

**Pivot Pin:** Stainless Steel

**Insert (Wedge & Friction):** TPE Grey

### Plain Chain FUPC-5

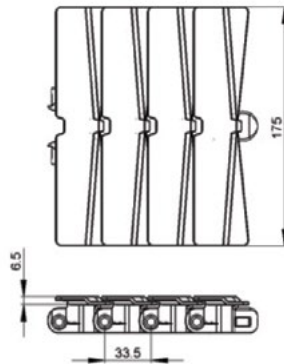
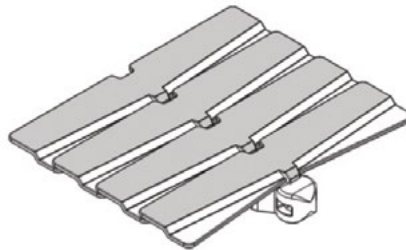

**UOM:** 5 Meter / box

Application: Suitable for horizontal and slope < 5° transport of products with accumulation.

### Roller Plain Chain FUPC-5R

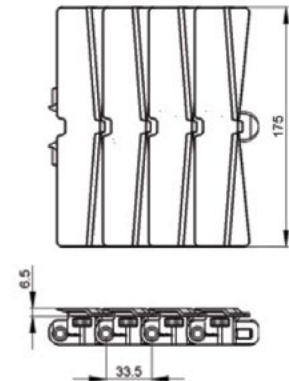
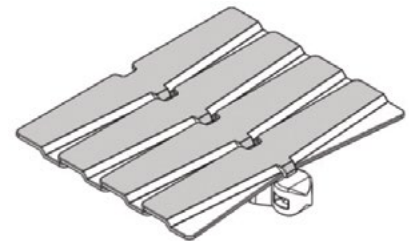

**UOM:** 5 Meter / box

Application: Suitable for horizontal and slope < 5° transport of products with accumulation.

**Note:** Friction Reducing Roller Chain recommended for high speed or high load plain bends

### Friction Top Chain FUFT-5

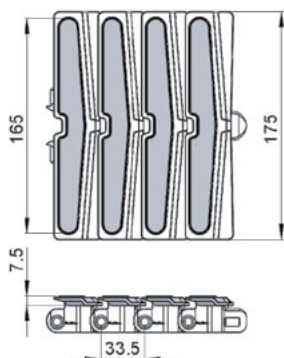
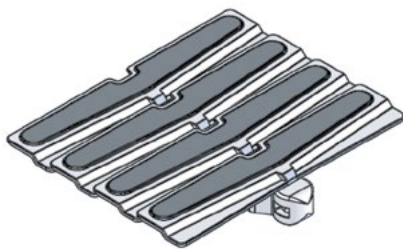

**UOM:** 5 Meter / box

Application: Suitable for horizontal and slope ≤ 30° transport of products without accumulation.

### Roller Friction Top Chain FUFT-5R

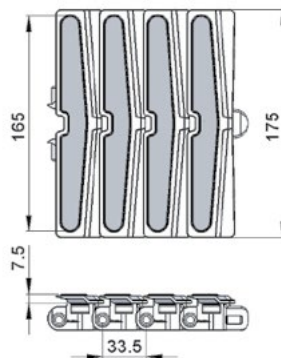
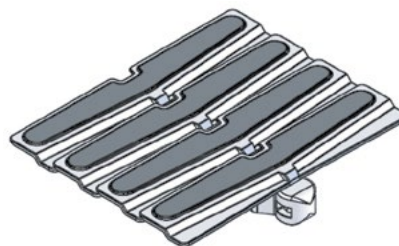

**UOM:** 5 Meter / box

Application: Suitable for horizontal and slope ≤ 30° transport of products without accumulation.

**Note:** Friction Reducing Roller Chain recommended for high speed or high load plain bends

### Twist Chain FUPC-5M

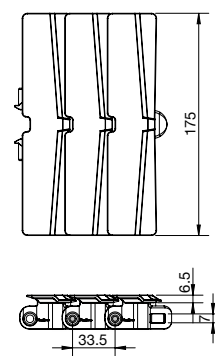
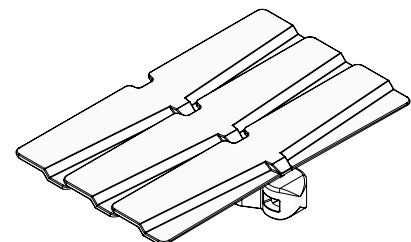

**UOM:** 5 Meter / box

Application: Suitable twist conveyor beam; horizontal and slope < 5° transport of products with accumulation.

# SU SERIES: 180 mm

SU Direct End Drive without Motor (LEFT)  
SUDD-A180-0L

SU Direct End Drive without Motor (RIGHT)  
SUDD-A180-0R

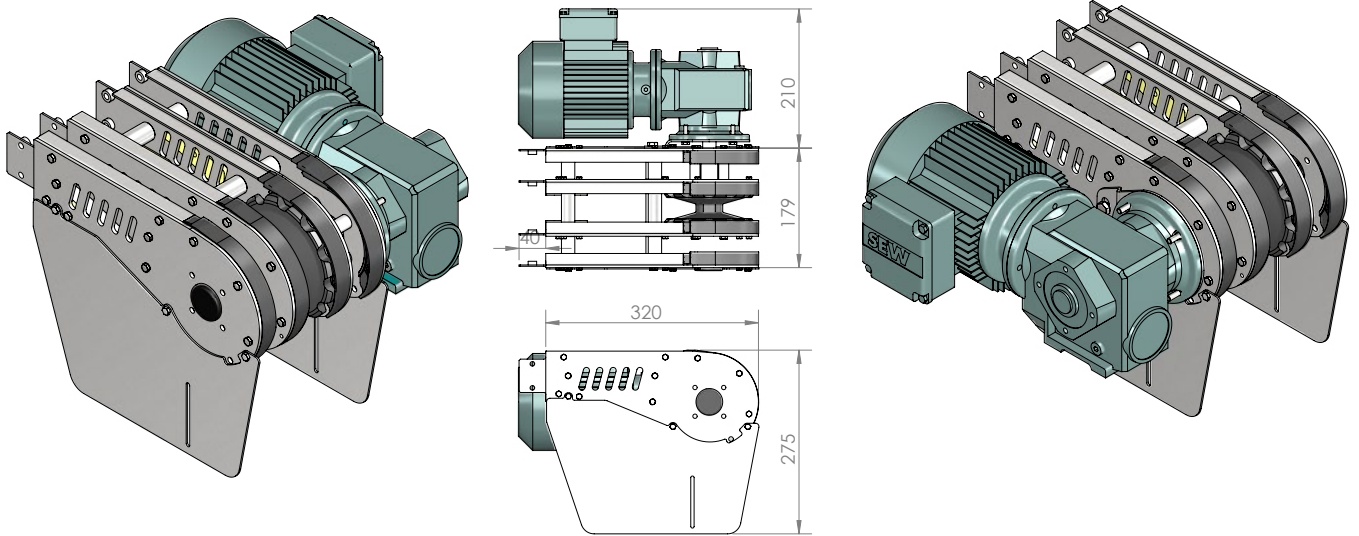

**Max Traction Force: 1250N**

The Direct End Drive Unit is without torque limiter. See page 66-67 for Gearmotor options.

**UOM: pc**

Chain required 2-way: 0.8 meter    Slide rail required 2-way: 0.9 meter

SU Idler End-A180

SUIE-A180

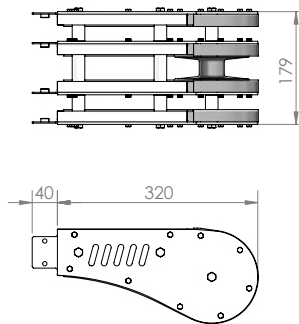
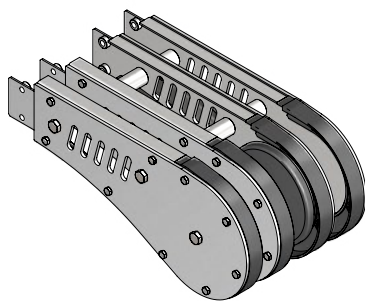

**UOM: pc**

Chain required 2-way: 0.8 meter  
Slide rail required 2-way: 0.9 meter

SEW gearmotors are products of SEW Eurodrive

**SU Horizontal Plain Bend 30°**

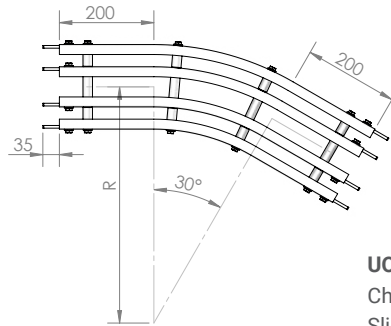
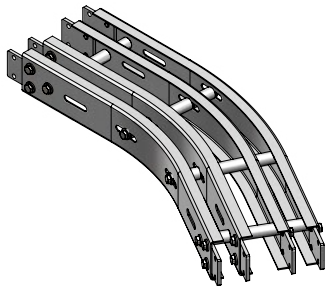

**Horizontal plain bend, 30° ± 1°**

- R = 500 ± 10 mm      **SUHB-30R500**
- R = 700 ± 10 mm      **SUHB-30R700**
- R = 1000 ± 10 mm     **SUHB-30R1000**

**UOM: pc**

Chain required 2-way (500, 700, 1000): 1.4, 1.6, 1.9 meter  
 Slide rail required 2-way (500, 700, 1000): 4.0, 4.7, 5.6 meter

**SU Horizontal Plain Bend 45°**

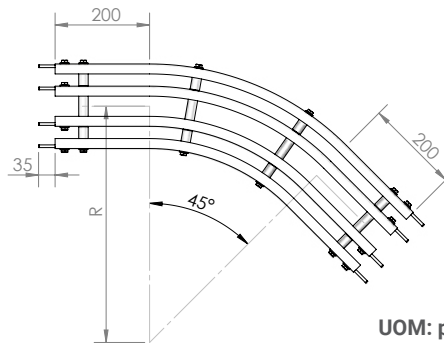
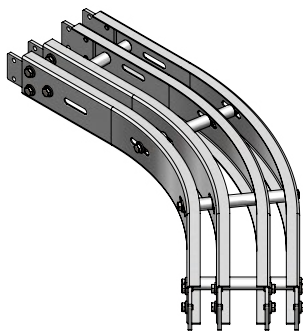

**Horizontal plain bend, 45° ± 1°**

- R = 500 ± 10 mm      **SUHB-45R500**
- R = 700 ± 10 mm      **SUHB-45R700**
- R = 1000 ± 10 mm     **SUHB-45R1000**

**UOM: pc**

Chain required 2-way (500, 700, 1000): 1.6, 2.0, 2.4 meter  
 Slide rail required 2-way (500, 700, 1000): 4.8, 5.8, 7.2 meter

**SU Horizontal Plain Bend 90°**

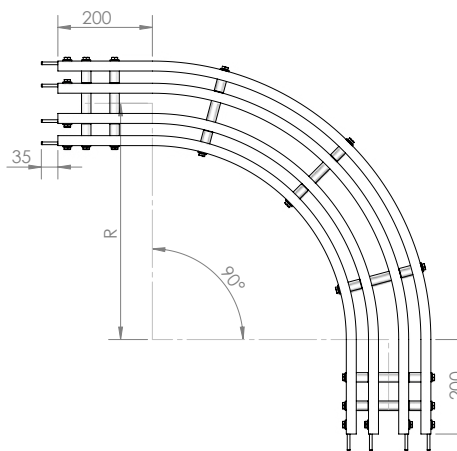
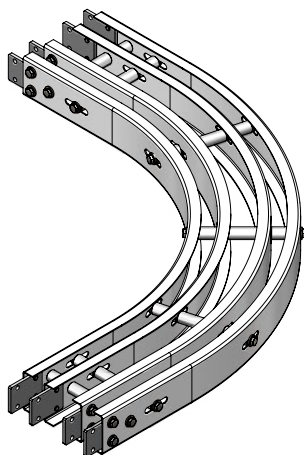

**Horizontal plain bend, 90° ± 1°**

- R = 500 ± 10 mm      **SUHB-90R500**
- R = 700 ± 10 mm      **SUHB-90R700**
- R = 1000 ± 10 mm     **SUHB-90R1000**

**UOM: pc**

Chain required 2-way (500, 700, 1000): 2.4, 3.1, 4.0 meter  
 Slide rail required 2-way (500, 700, 1000): 7.2, 9.1, 12.0 meter



SU Horizontal Plain Bend 5-180°

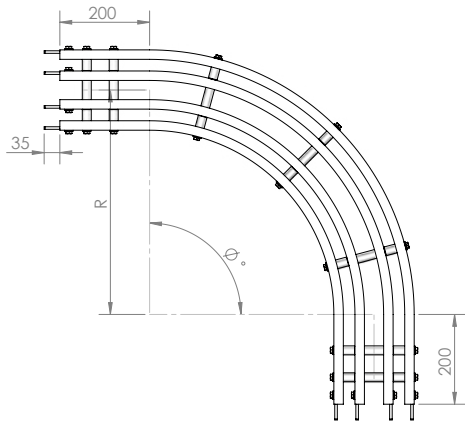

Example for SU Horizontal Plain Bend Ordering

Horizontal plain bend,  $\theta \pm 1^\circ$

- R = 500 ± 10 mm      **SUHB-ØR500**
- R = 700 ± 10 mm      **SUHB-ØR700**
- R = 1000 ± 10 mm    **SUHB-ØR1000**

If an angle of 120° is needed for radius R500 horizontal plain bend, the ordering part number is

**SUHB-70R500**

**UOM: pc**

Chain required 2-way (500, 700, 1000): meter (Variable to angle)  
 Slide rail required 2-way (500, 700, 1000): meter (Variable to angle)

SU Vertical Bend 5°

SUVB-5R400

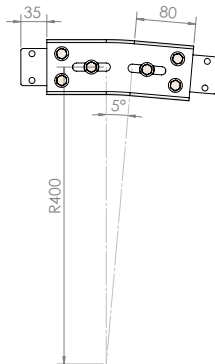
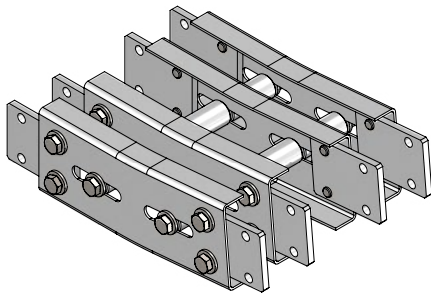

**UOM: pc**

Chain required 2-way: 0.4 meter  
 Slide rail required 2-way: 1.6 meter

SU Vertical Bend 15°

SUVB-15R400

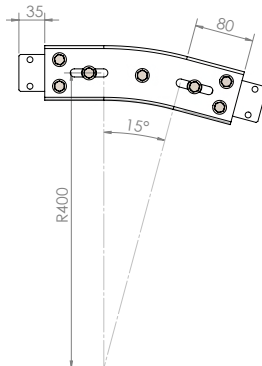
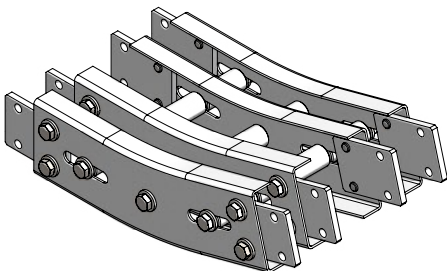

**UOM: pc**

Chain required 2-way: 0.6 meter  
 Slide rail required 2-way: 2.2 meter

SU Vertical Bend 30°

SUVB-30R400

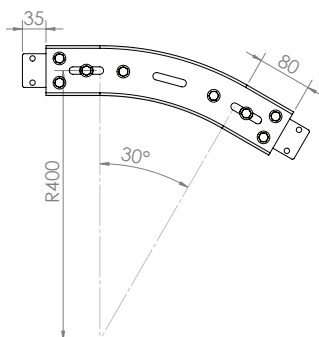
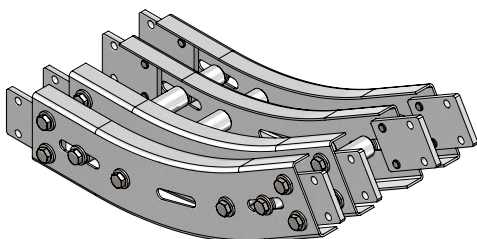

**UOM: pc**

Chain required 2-way: 0.8 meter  
 Slide rail required 2-way: 3.0 meter

**SU Vertical Bend 5° - 90°**

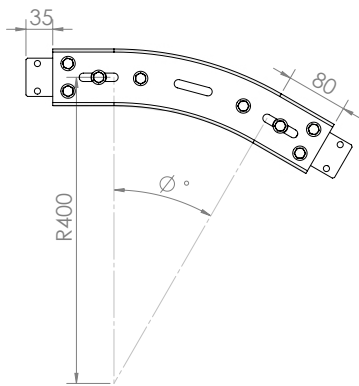

**Example for SU Vertical Bend Ordering**

- Vertical bend,  $\varnothing^\circ \pm 1^\circ$

If an angle of 25° is needed for vertical bend, the ordering part number is

**SUVB-25R400**

The outer bend is assembled using connecting strip (SACS-50x75). Angle of  $\varnothing^\circ$  must be indicated when ordering.

**SU Horizontal beam support bracket – Stainless Steel**

**SAHBS-90**

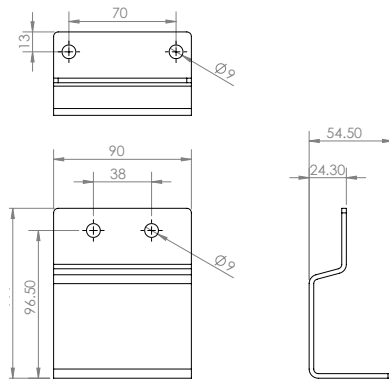
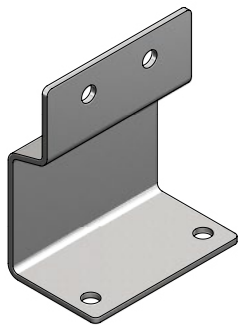

UOM: pc

**SU Horizontal Tripod Support**

SBSU-HXXXX, where XXXX = H Height (mm)

**SU Adjustable Angle Tripod Support**

SBSU-A-HXXXX, where XXXX = H Height (mm)

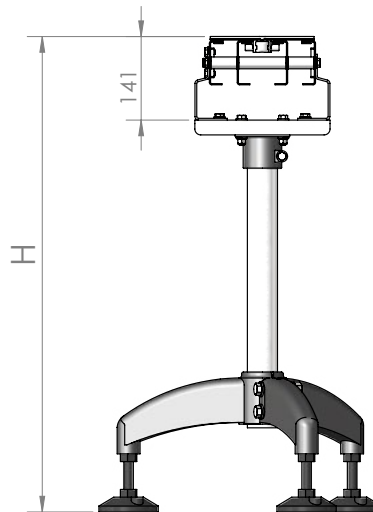
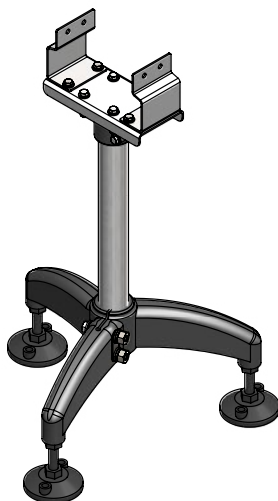

UOM: pc  
Includes Beam Support Brackets

## SV Series

### SV Series:

**Beam Width:** 260 mm

**Product Width:** Refer to Guide Rail Assembly

### Accessories Needed:

**Slide Rail Required:** FASR-25, FASR-25U, FASR-25X

**Slide Rail Color:** White or Natural Color

**Slide Rail Material:** HDPE, UHMWPE or Special PE

**Slide Rail Rivet:** FASLS-M5

Connecting strip is used to connect two beams.

**Connecting Strip:** SACS-50x70

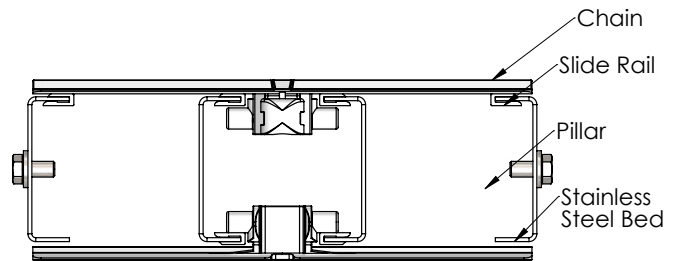

### Conveyor Beam SVCB-LXXXX

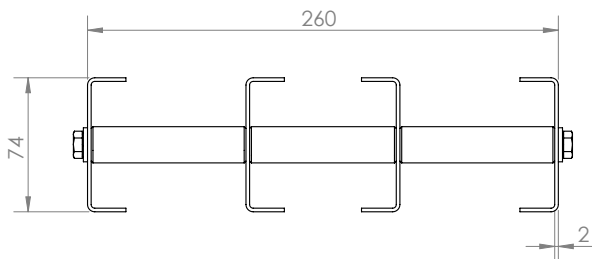

Where:  
XXXX = Length (mm)

UOM: each

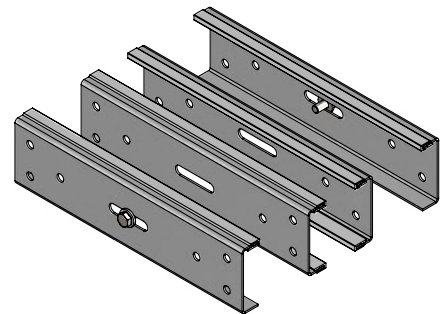
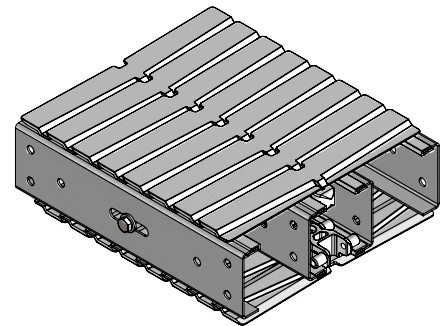

### Chain Connecting Module SVCC-300

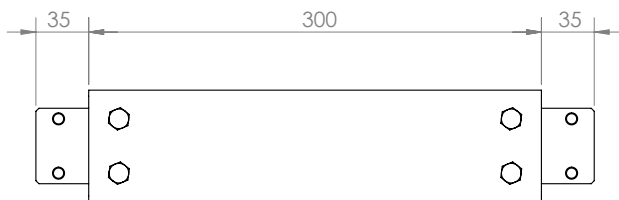

### Connecting Strip – Stainless Steel

SACS-50x70

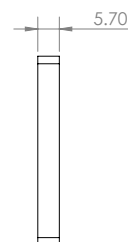
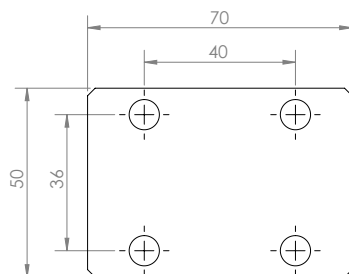
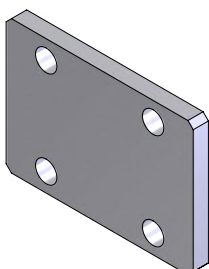

UOM: pc

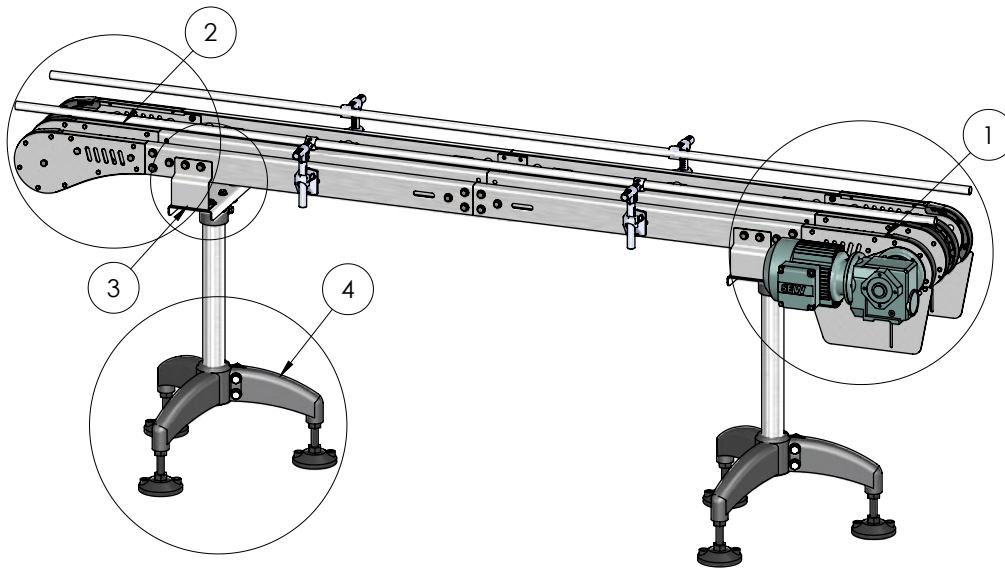

2

**Idler End**

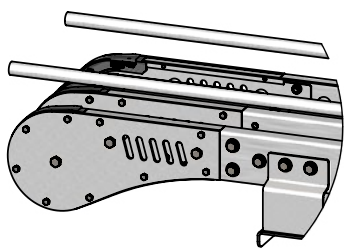

1

**Direct Drive**

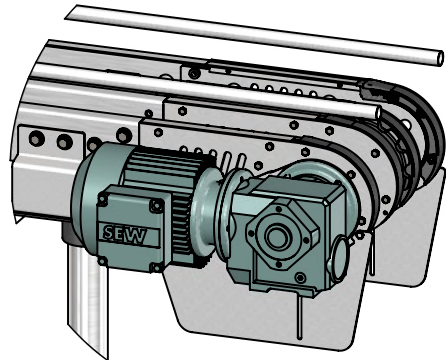

3

**Horizontal Beam Support**

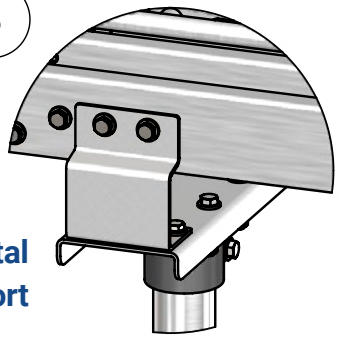

4

**Tripod Structure**

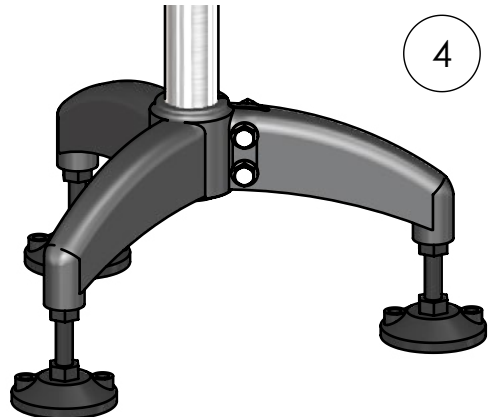

### Chain Common Data

**Packaging:** 5 m per box

**Pitch:** 33.5 mm

**Width:** 255 mm

**Tensile Strength at 20°C:** 6000N

**Color:** White

#### Material:

**Chain:** White Acetal / POM

**Pivot:** Polyamide

**Pivot Pin:** Stainless Steel

**Insert (Wedge & Friction):** TPE Grey

### Plain Chain FVPC-5

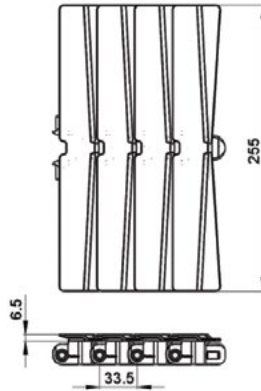
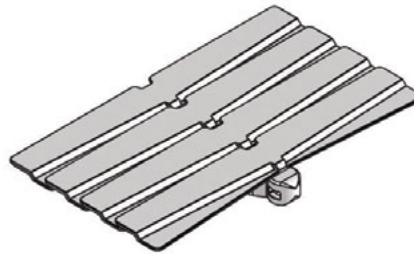

**UOM:** 5 Meter / box

Application: Suitable for horizontal and slope < 5° transport of products with accumulation.

### Roller Plain Chain FVPC-5R

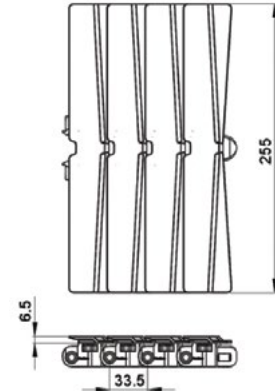
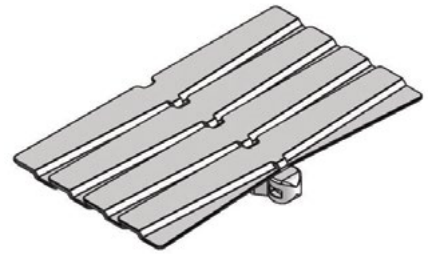

**UOM:** 5 Meter / box

Application: Suitable for horizontal and slope < 5° transport of products with accumulation.

**Note:** Friction Reducing Roller Chain recommended for high speed or high load plain bends

### Friction Top Chain FVFT-5

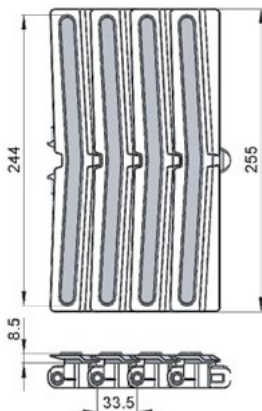
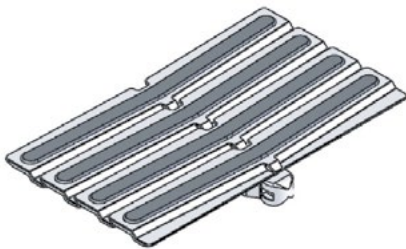

**UOM:** 5 Meter / box

Application: Suitable for horizontal and slope ≤ 30° transport of products without accumulation.

### Roller Friction Top Chain FVFT-5R

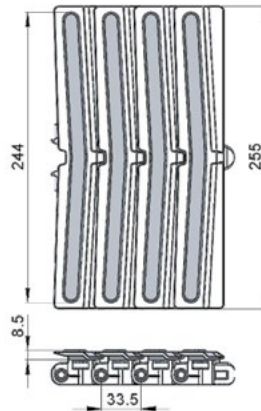
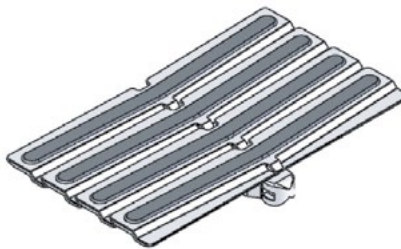

**UOM:** 5 Meter / box

Application: Suitable for horizontal and slope ≤ 30° transport of products without accumulation.

**Note:** Friction Reducing Roller Chain recommended for high speed or high load plain bends

### Twist Chain FVPC-5M

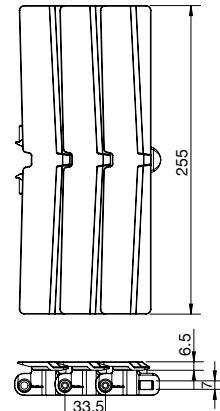
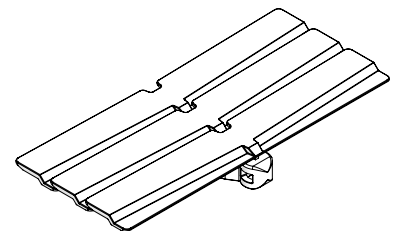

**UOM:** 5 Meter / box

Application: Suitable twist conveyor beam; horizontal and slope < 5° transport of products with accumulation.



**SV Direct End Drive without Motor (LEFT)**

SVDD-A260-0L

**SV Direct End Drive without Motor (RIGHT)**

SVDD-A260-0R

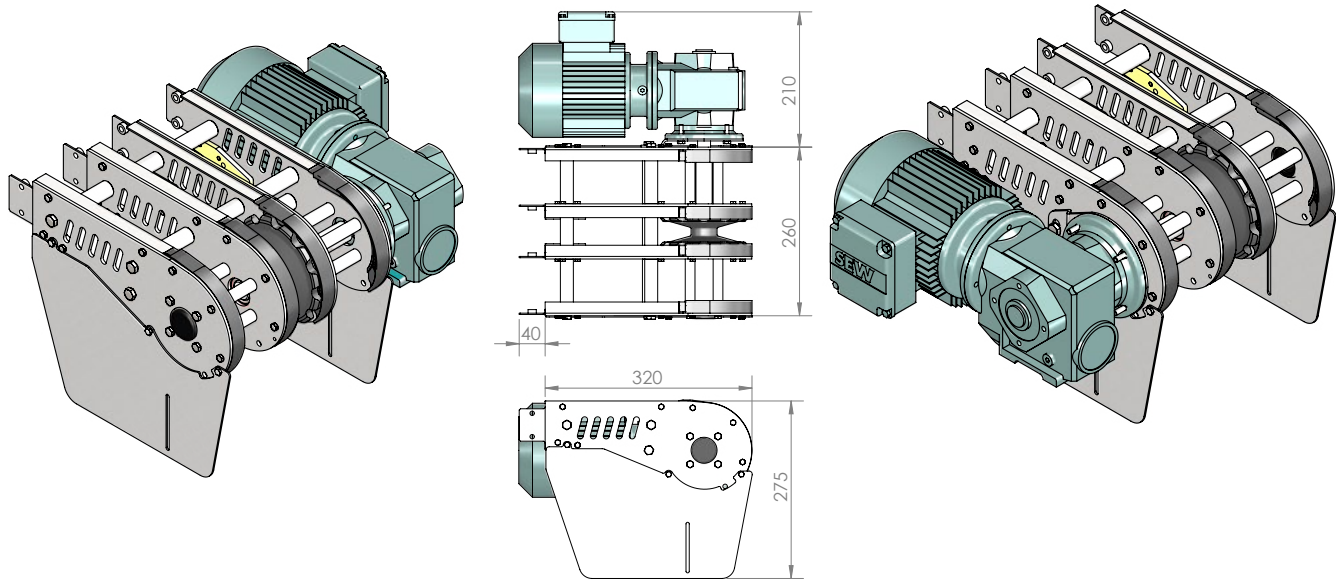

**Max Traction Force: 1250N**

The Direct End Drive Unit is without torque limiter. See page 66-67 for Gearmotor options.

**UOM: pc**

Chain required 2-way: 0.8 meter    Slide rail required 2-way: 0.9 meter

**SV Idler End-A260**

**SVIE-A260**

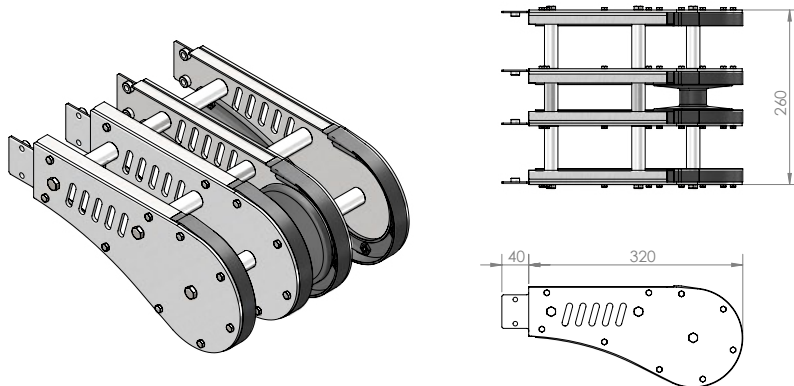

**UOM: pc**

Chain required 2-way: 0.8 meter  
Slide rail required 2-way: 0.9 meter

SEW gearmotors are products of SEW Eurodrive

SV Horizontal Plain Bend 30°

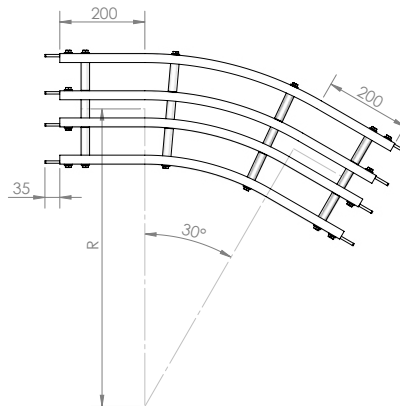
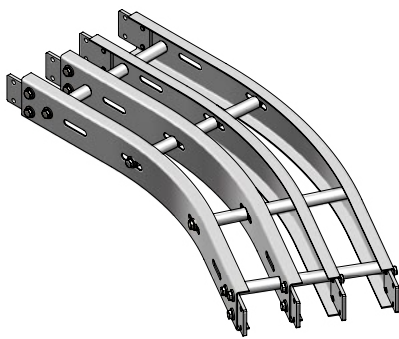

**Horizontal plain bend, 30° ± 1°**

- R = 700 ± 10 mm      **SVHB-30R700**
- R = 1000 ± 10 mm    **SVHB-30R1000**

**UOM: pc**

Chain required 2-way (700, 1000): 1.6, 1.9 meter  
 Slide rail required 2-way (500, 700, 1000): 4.7, 5.6 meter

SV Horizontal Plain Bend 45°

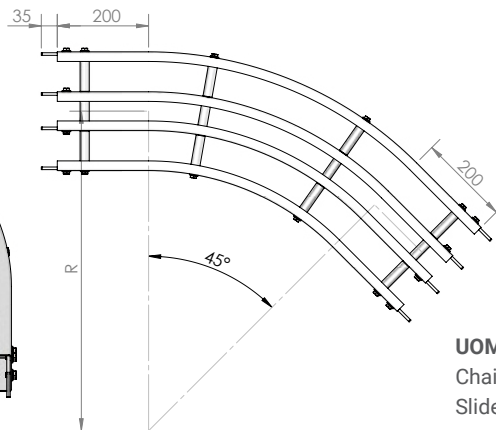
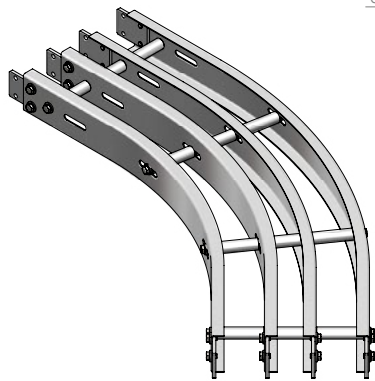

**Horizontal plain bend, 45° ± 1°**

- R = 700 ± 10 mm      **SVHB-45R700**
- R = 1000 ± 10 mm    **SVHB-45R1000**

**UOM: pc**

Chain required 2-way (700, 1000): 2.0, 2.4 meter  
 Slide rail required 2-way (700, 1000): 5.8, 7.2 meter

SV Horizontal Plain Bend 90°

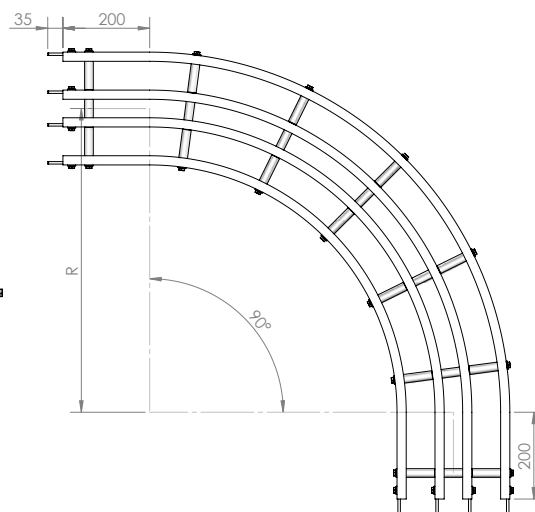

**Horizontal plain bend, 90° ± 1°**

- R = 700 ± 10 mm      **SVHB-90R700**
- R = 1000 ± 10 mm    **SVHB-90R1000**

**UOM: pc**

Chain required 2-way (700, 1000): 3.1, 4.0 meter  
 Slide rail required 2-way (700, 1000): 9.1, 12.0 meter

**SV Horizontal Plain Bend 5-180°**

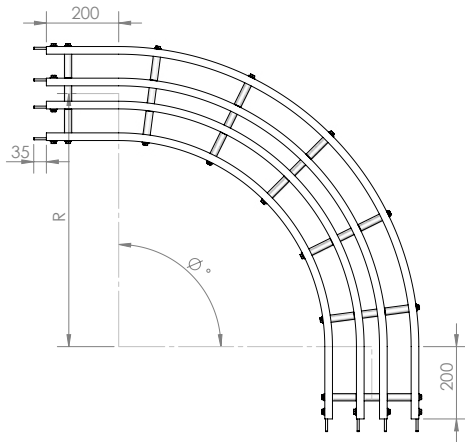

**Example for SV Horizontal Plain Bend Ordering**

**Horizontal plain bend,  $\theta \pm 1^\circ$**

R = 700 ± 10 mm      **SVHB-ØR700**

R = 1000 ± 10 mm    **SVHB-ØR1000**

If an angle of 120° is needed for radius R700 horizontal plain bend, the ordering part number is

**SVHB-120R500**

**UOM: pc**

Chain required 2-way (700, 1000): meter (Variable to angle)

Slide rail required 2-way (700, 1000): meter (Variable to angle)

**SV Vertical Bend 5°**

**SVVB-5R400**

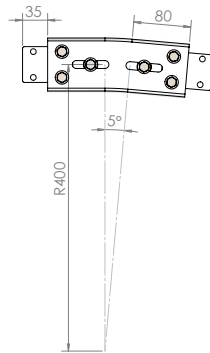
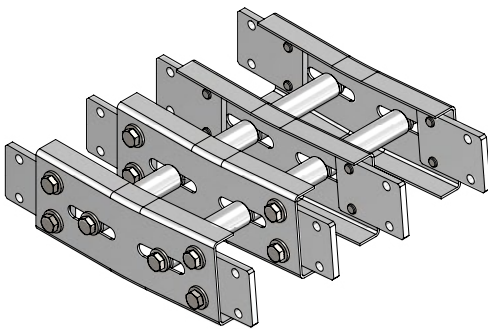

**UOM: pc**

Chain required 2-way: 0.4 meter

Slide rail required 2-way: 1.6 meter

**SV Vertical Bend 15°**

**SVVB-15R400**

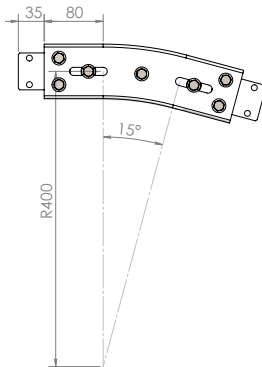
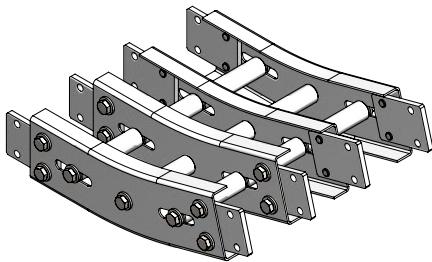

**UOM: pc**

Chain required 2-way: 0.6 meter

Slide rail required 2-way: 2.2 meter

**SV Vertical Bend 30°**

**SVVB-30R400**

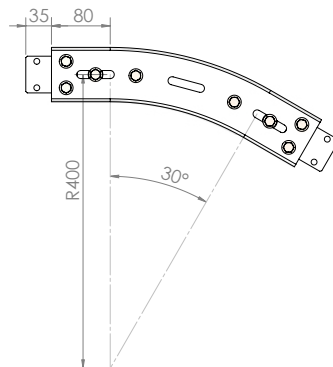
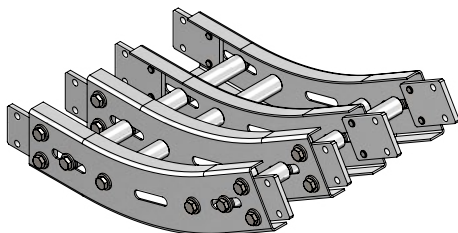

**UOM: pc**

Chain required 2-way: 0.8 meter

Slide rail required 2-way: 3.0 meter

SU Vertical Bend 5° - 90°

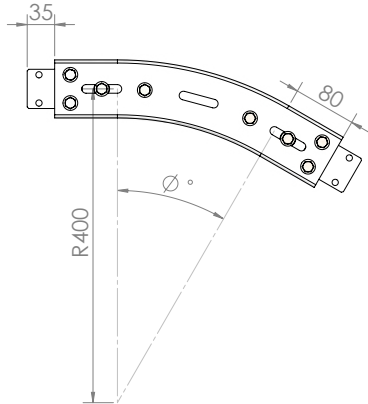

**Example for SV Vertical Bend Ordering**

- Vertical bend,  $\emptyset^\circ \pm 1^\circ$

If an angle of 25° is needed for vertical bend, the ordering part number is

**SVVB-25R400**

*The outer bend is assembled using connecting strip (SACS-50x75). Angle of  $\emptyset^\circ$  must be indicated when ordering.*

SV Horizontal beam support bracket – Stainless Steel

SAHBS-90

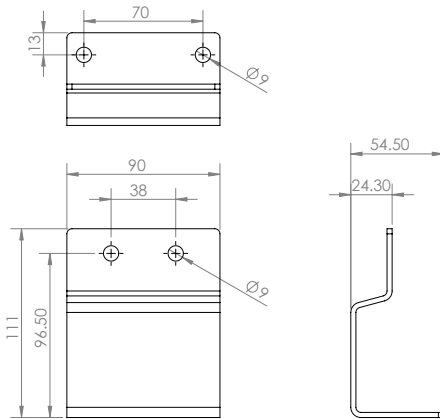
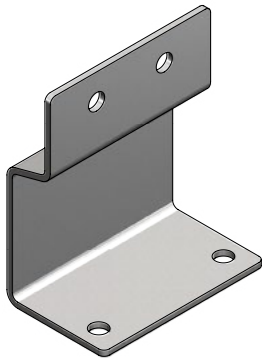

UOM: pc

SV Horizontal Tripod Support

SBSV-HXXXX, where XXXX = H Height (mm)

SV Adjustable Angle Tripod Support

SBSV-A-HXXXX, where XXXX = H Height (mm)

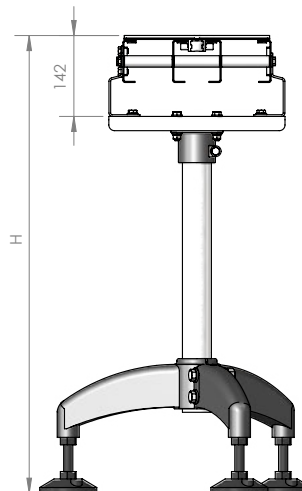

UOM: pc  
Includes Beam Support Brackets

FASR-25	HDPE Slide Rail - White	"Normal Application"
FASR-25U	UHMW-PE Slide Rail - White	"Low Friction, suitable for accumulation"
FASR-25X	Special PE Slide Rail - Blue	"Lowest Friction, suitable for accumulation"
FASR-25T	PAPE Slide Rail - Grey	"High abrasive and High load"
FASR-25CD	Conductive Slide Rail - Black	"Static conductive"
FASR-25P	PVDF Slide Rail - White	"For Abrasive application"

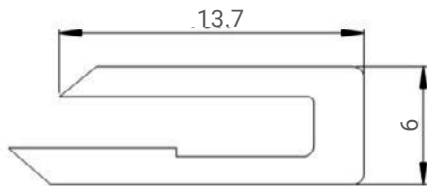

See page 70 for detail slide rail information

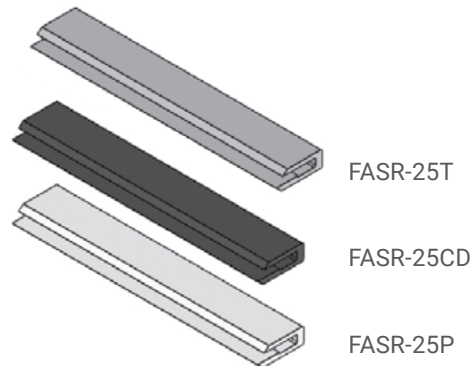
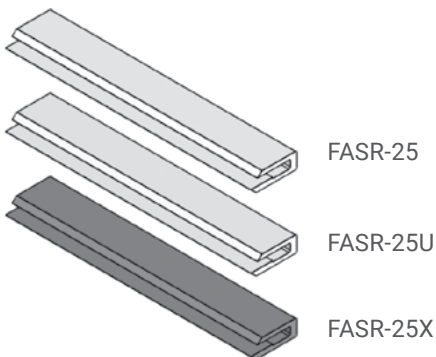

UOM: 25 meter / roll

**FASLR-4x6** Aluminum Rivet for Slide Rail

**FASLS-M5** Nylon Set Screw for Slide Rail

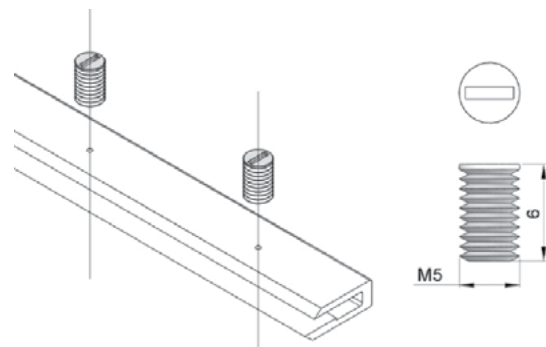
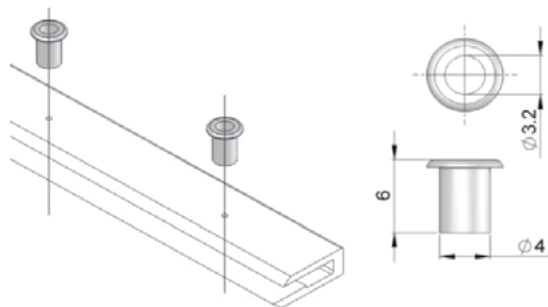

UOM: 50 pcs / pk

UOM: 50 pcs / pk



**SASHN-1M8** M8 Single Nut, Non-Rotating

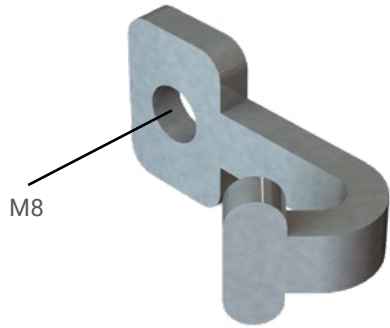

UOM: 10 pcs / pk

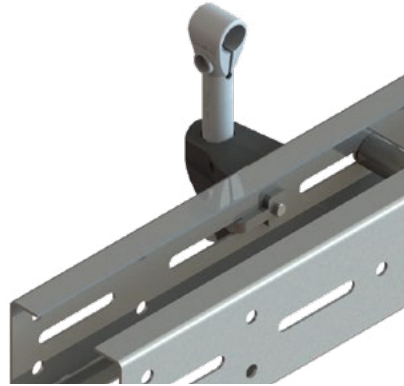

**SASHN-2M8** M8 Double Nut, Non-Rotating

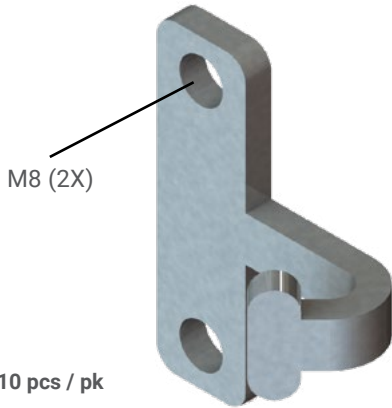

UOM: 10 pcs / pk

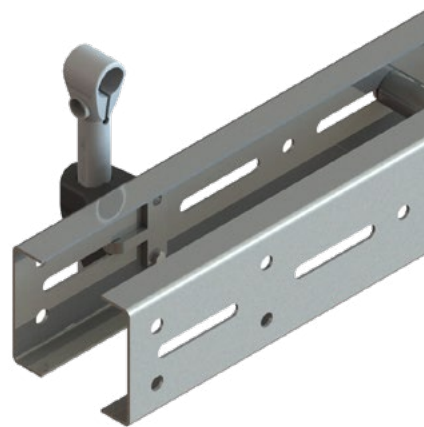

**SAFW-M8** M8 Flat Washer – Stainless Steel

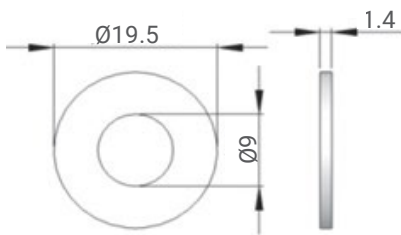

UOM: 50 pcs / pk

**SALN-M8** M8 Lock Nut – Stainless Steel

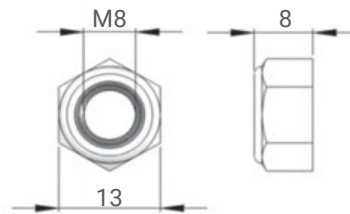

UOM: 50 pcs / pk

**SAHB-M8xXX** Hex Bolt, M8 – Stainless Steel. Where XX = L = Length (= 12, 16, 25, 45, 100 mm)

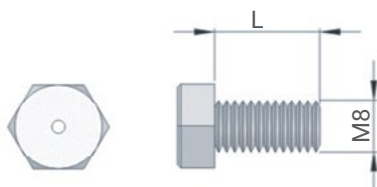

UOM: 50 pcs / pk

**SADBS-WW-HHHH** Direct Drive Tripod Support

Where WW = Width (SS = 65; SM = 85; SC = 105; SU = 180; SV = 260)  
 HHHH = Height = Top of Chain Height

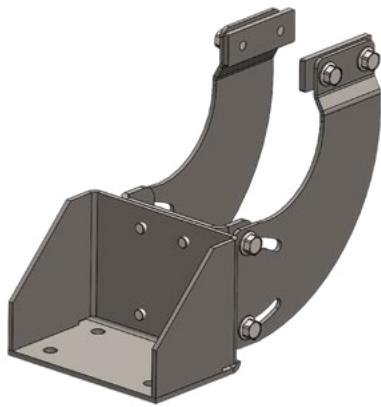

UOM: pc  
 Includes Beam Support Bracket

**SABS-38x4** Beam Spacer, Stainless Steel

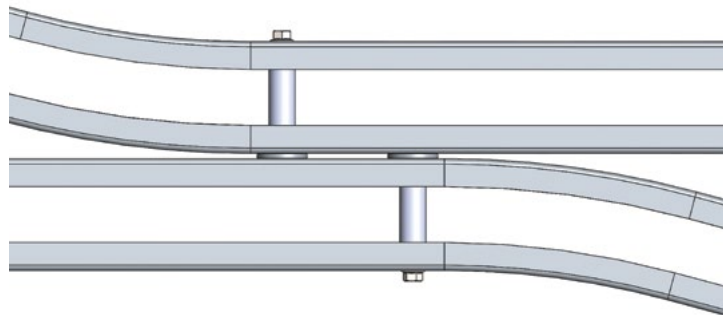
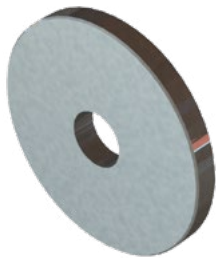

UOM: 10 pcs / pk

**FAFR-35** Free Roller – POM

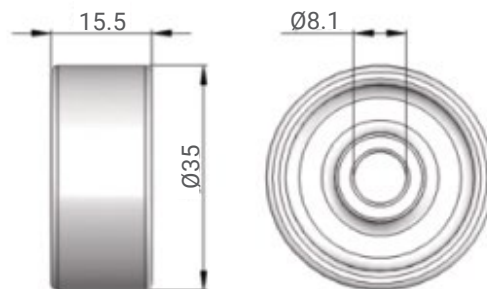

UOM: 10 pcs / pk

**FAFR-18** Free Roller – POM

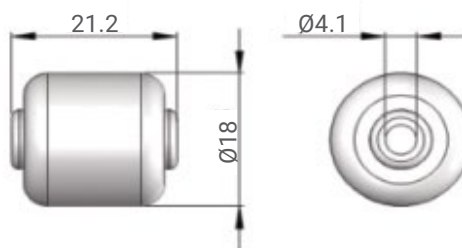

UOM: 10 pcs / pk

**FAFR-11** Free Roller - POM

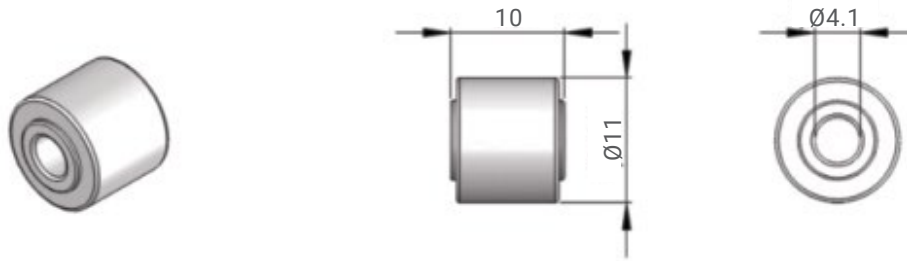

UOM: 10 pcs / pk

**FASR-75x15** Sponge Roller, Sponge Rubber

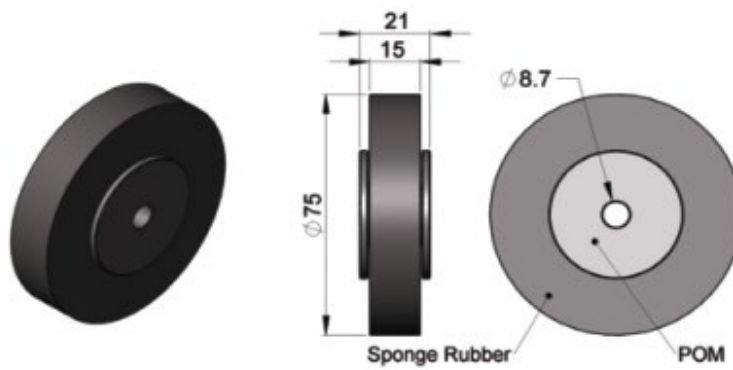

UOM: 10 pcs / pk

**FASR-75x19P** PVC Roller c/w POM Core & Screw

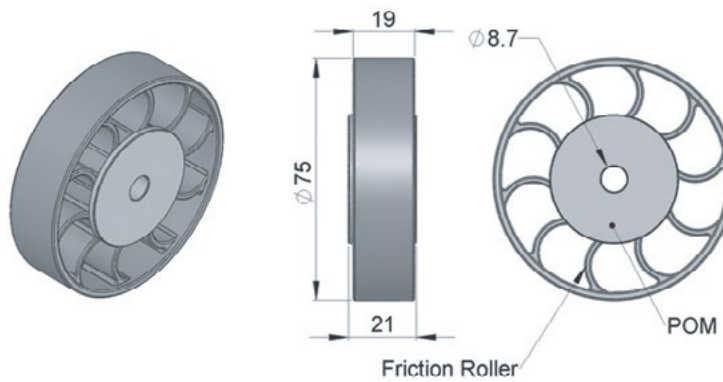

UOM: 10 pcs / pk

**SG Guide Assembly** 12/18 mm Rail, Fully Adjustable

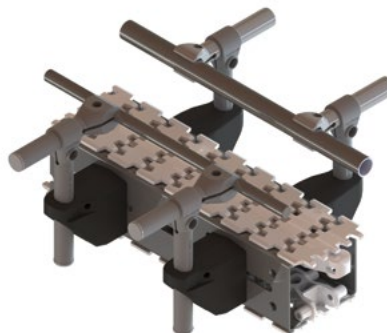
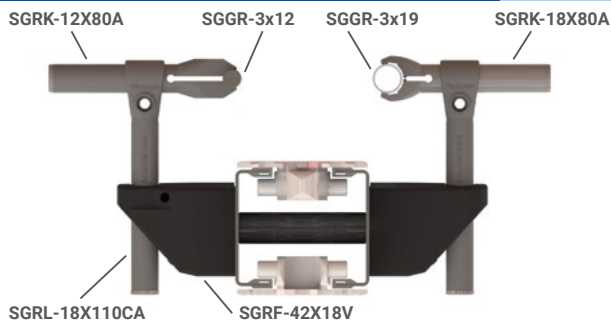

**SG Guide Assembly** 12/18 mm Rail, Adjustable Width/Height

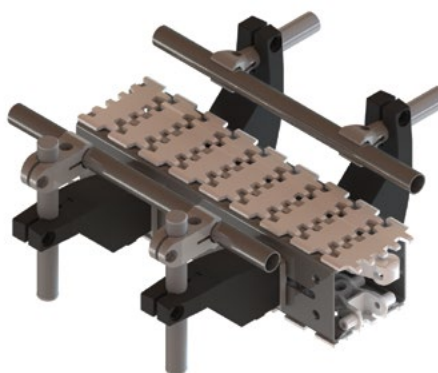
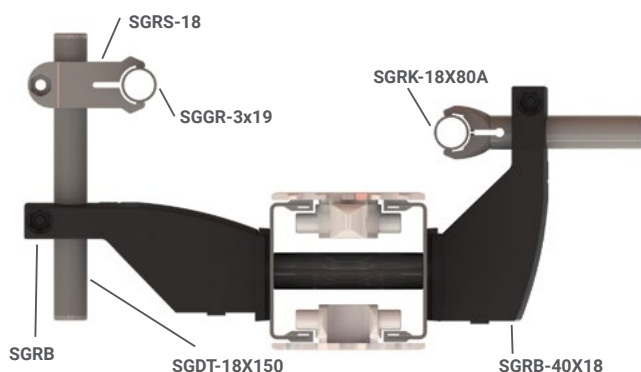

**SG Guide Assembly** 12/18 mm Rail, Twin Rail

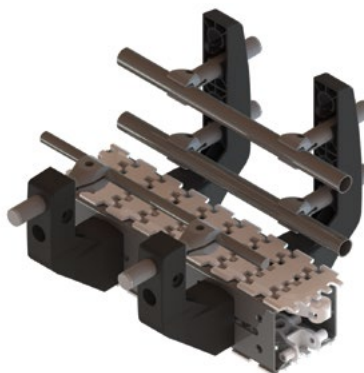
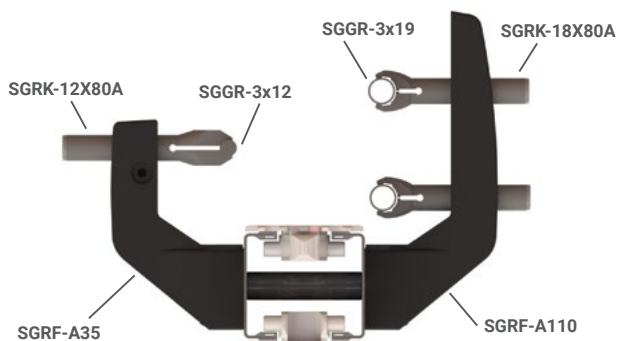

**SG Guide Assembly** 18 mm Rail, Overhead Guide

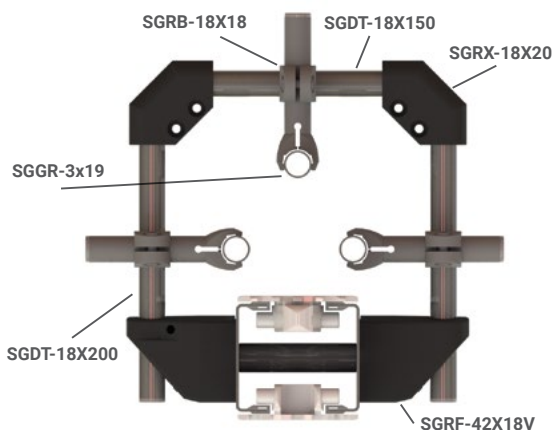

**FGRR-15X20P** Guide Rail Rectangular, 15 mm x 20 mm – HDPE

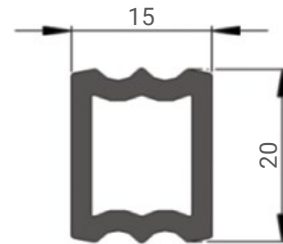
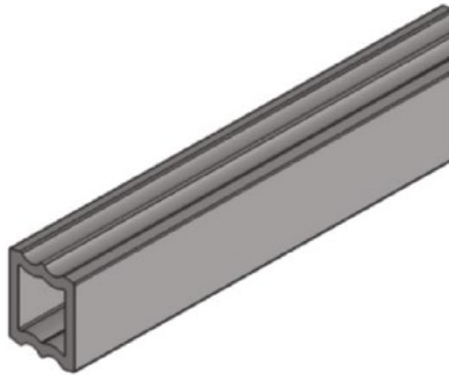

UOM: 3 meter / length

**SGGR-3x19 D = 19 mm** Guide Rail Tube – Stainless Steel

**SGGR-3x12 D = 12 mm** Guide Rail Solid Round – Stainless Steel

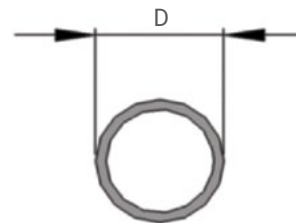
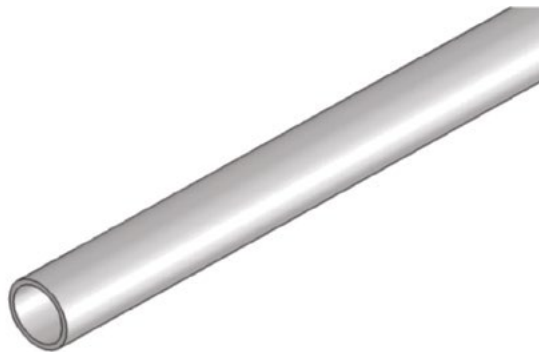

UOM: 3 meter / length

**SGDT-18x150 D = 19mm L = 150** Distance Tube – Stainless Steel

**SGDT-18x200 D = 19mm L = 200** Distance Tube – Stainless Steel

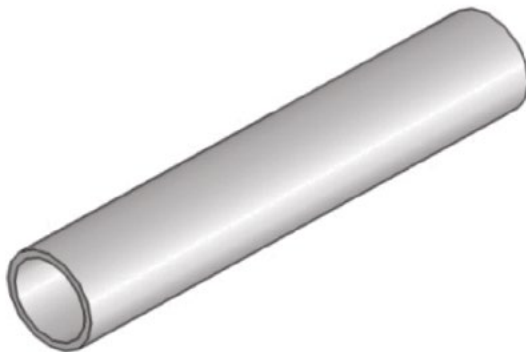

UOM: 10 pcs / pk



**SGRS-18**

Guide Rail Support - Polyamide

Stainless Steel Screw and Nuts

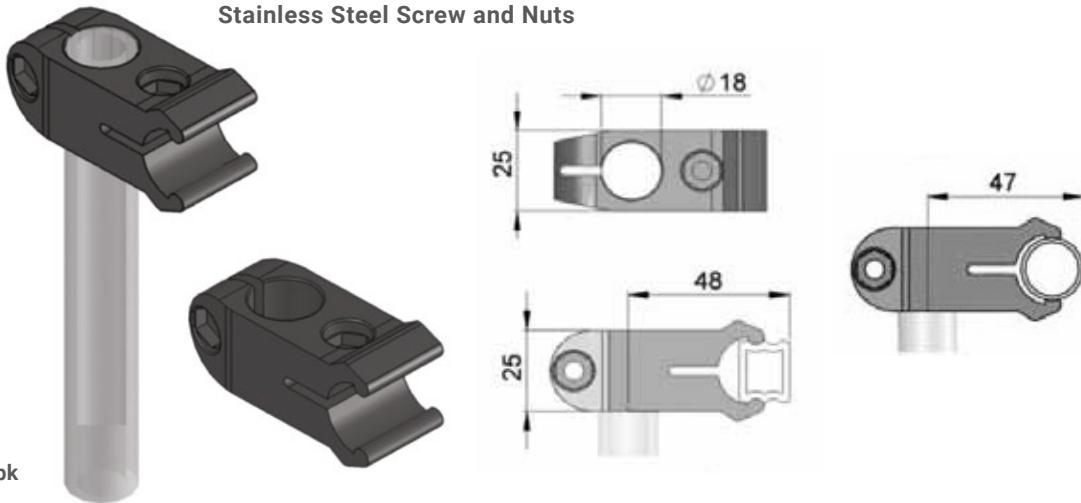

UOM: 10 pcs / pk

**SGRL-18x110C**

Guide Rail Support, L = 110mm - Polyamide

**SGRL-18x160C**

Guide Rail Support, L = 160mm - Polyamide

Stainless Steel Screw and Nuts

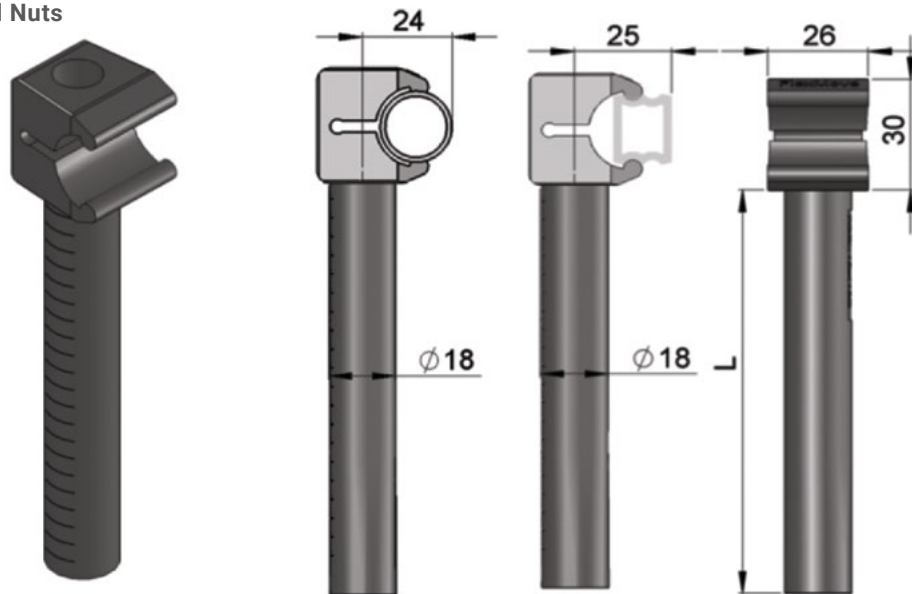

UOM: 10 pcs / pk

**SGRD-12x80**

Guide Rail Clamp Rod, L = 80mm - S/Steel

**SGRD-12x130**

Guide Rail Clamp Rod, L = 130mm - S/Steel

Stainless Steel Screw and Nuts

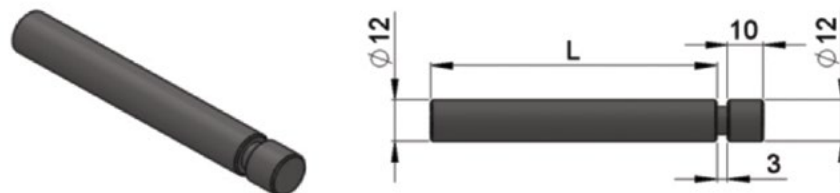

UOM: 10 pcs / pk

**SGRK-12** Guide Rail Clamp - Polyamide

Stainless Steel Screw and Nuts

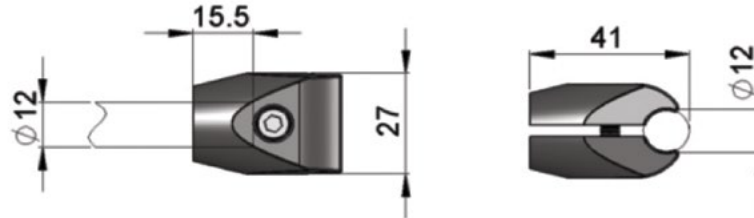

UOM: 10 pcs / pk

**SGRK-12x80A** Guide Rail Support, L = 80mm - Polyamide

**SGRK-12x130A** Guide Rail Support, L = 130mm - Polyamide

Stainless Steel Screw and Nuts

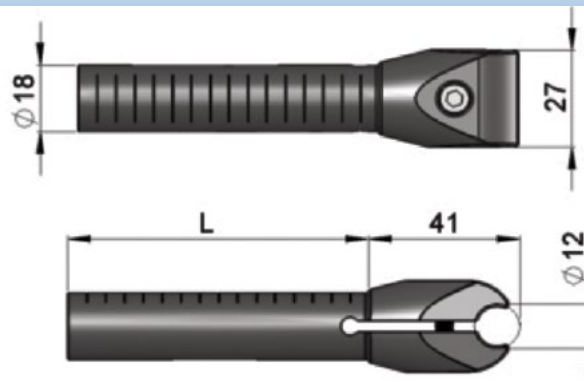

UOM: 10 pcs / pk

**SGRK-18x40A** Guide Rail Support, L = 40mm - Polyamide

**SGRK-18x60A** Guide Rail Support, L = 60mm - Polyamide

**SGRK-18x80A** Guide Rail Support, L = 80mm - Polyamide

**SGRK-18x130A** Guide Rail Support, L = 130mm - Polyamide

Stainless Steel Screw and Nuts

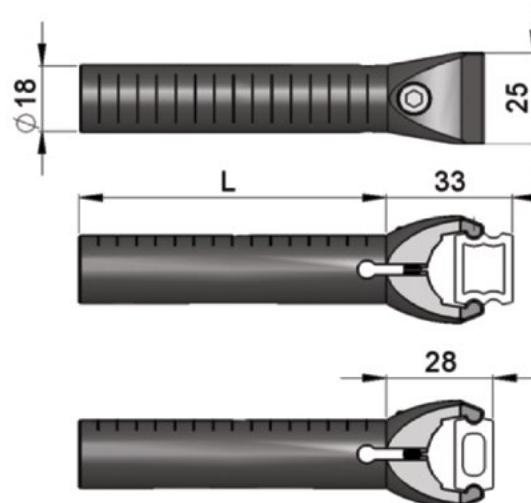

UOM: 10 pcs / pk

**SGRC-18x110C** Double Guide Rail Support, L = 110mm - Polyamide

**SGRC-18x160C** Double Guide Rail Support, L = 160mm - Polyamide

Stainless Steel Screw and Nuts

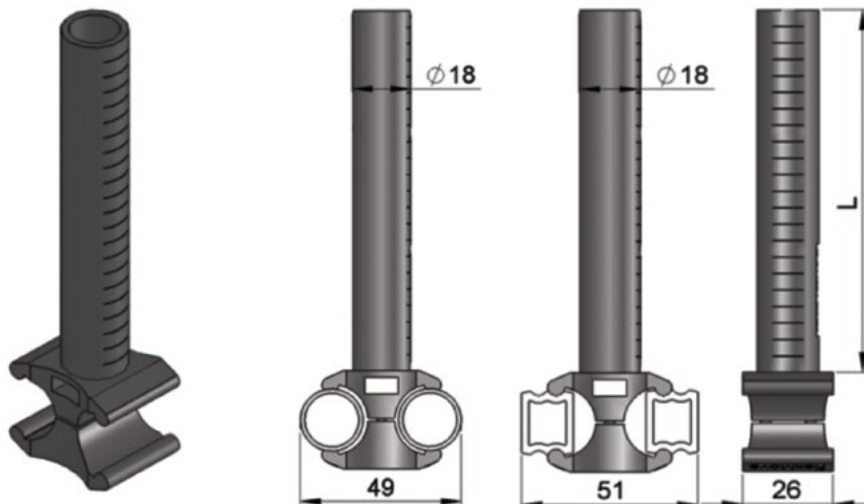

UOM: 10 pcs / pk

**FGEC-18** End cap. 18 mm Tube - Polyamide

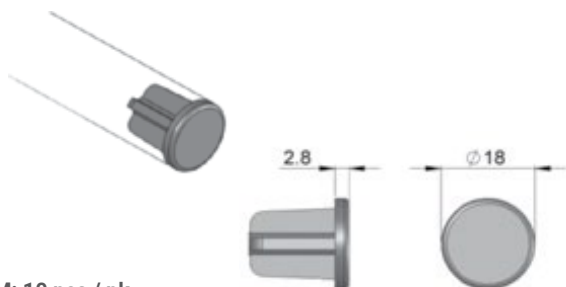

UOM: 10 pcs / pk

UOM: 10 pcs / pk

**SGRF-A35** Guide Rail Bracket Support A35 – Polyamide

Stainless Steel Screw and Nuts

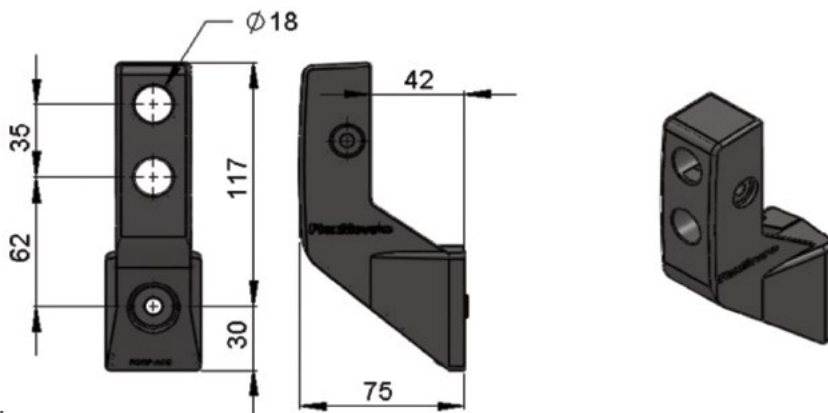

UOM: 10 pcs / pk

**SGRF-A110** Guide Rail Bracket Support A110 – Polyamide

Stainless Steel Screw and Nuts

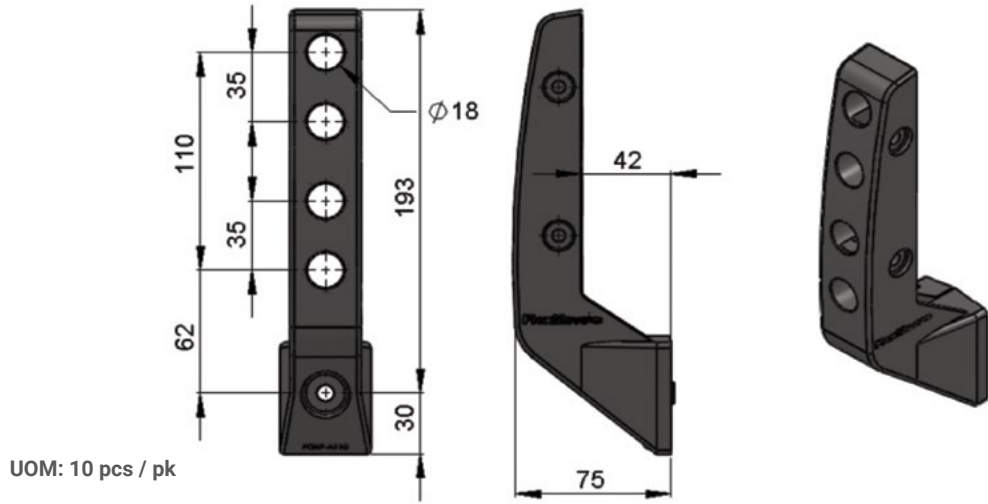

UOM: 10 pcs / pk

**FGRF-DP** FGRF Dummy Plug

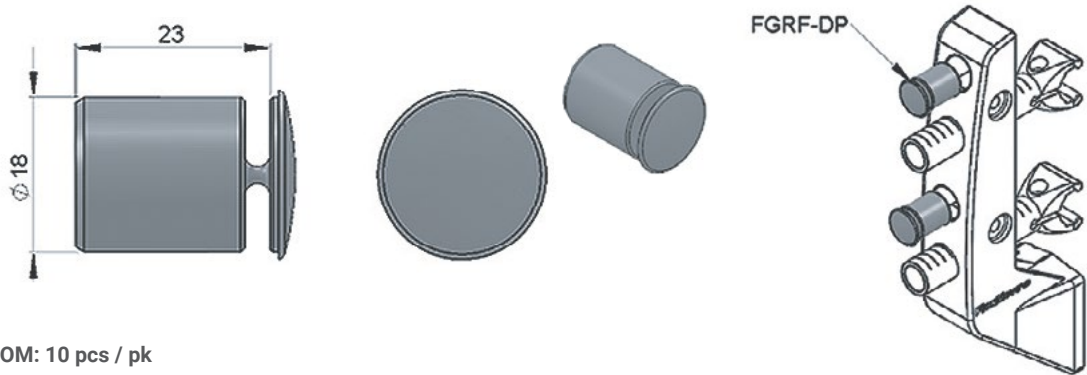

UOM: 10 pcs / pk

**SGRL-18x110CA** Guide Rail Support, L = 110mm - Polyamide

**SGRL-18x160CA** Guide Rail Support, L = 160mm - Polyamide

Stainless Steel Screw and Nuts

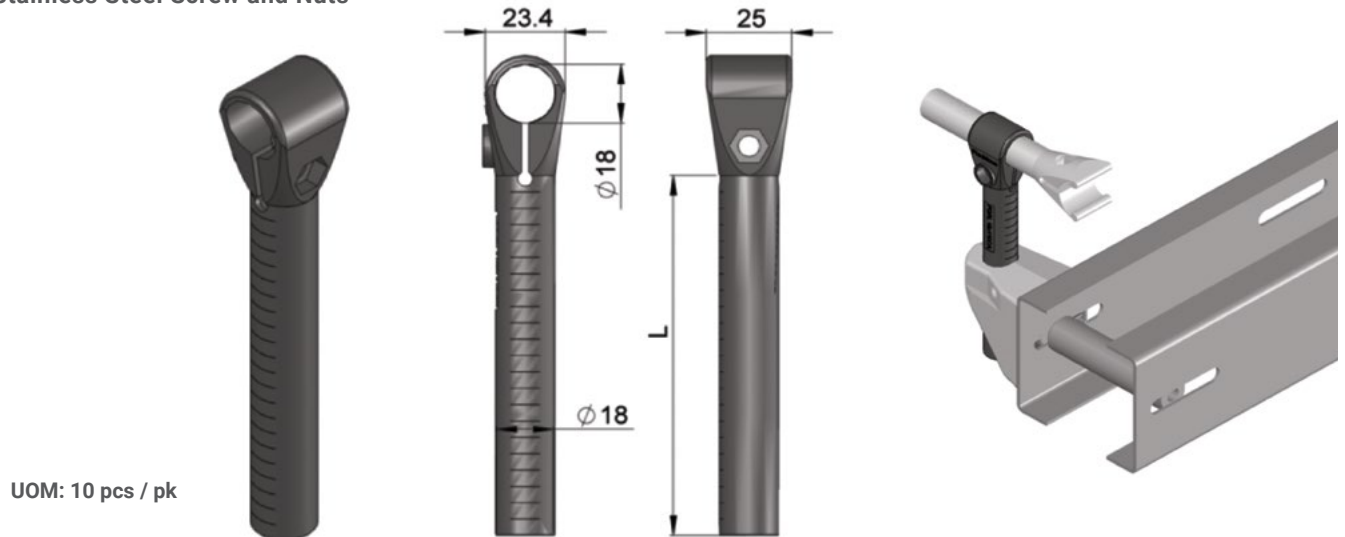

UOM: 10 pcs / pk

**SGRF-42x18V** Guide Rail Bracket – Polyamide

Stainless Steel Screw and Nuts

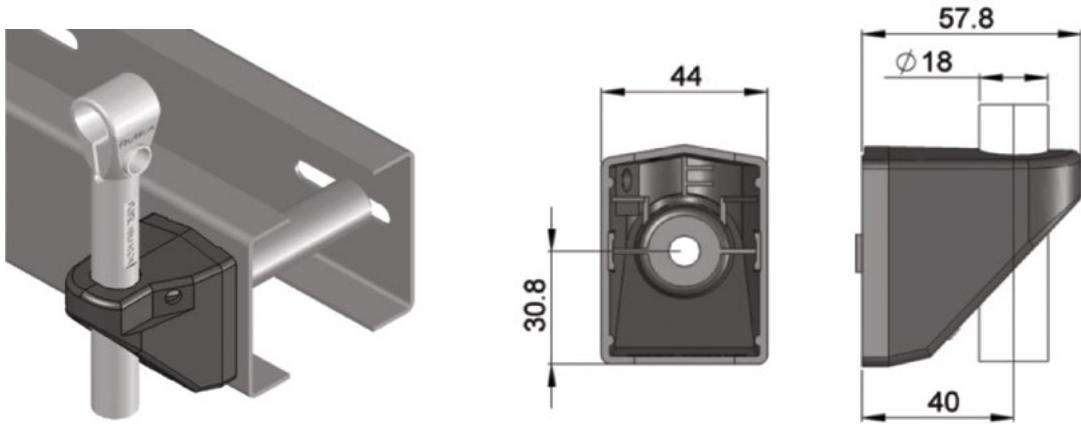

UOM: 10 pcs / pk

**FGRD-18A** Spacer for SGRF-42x18V - Polyamide

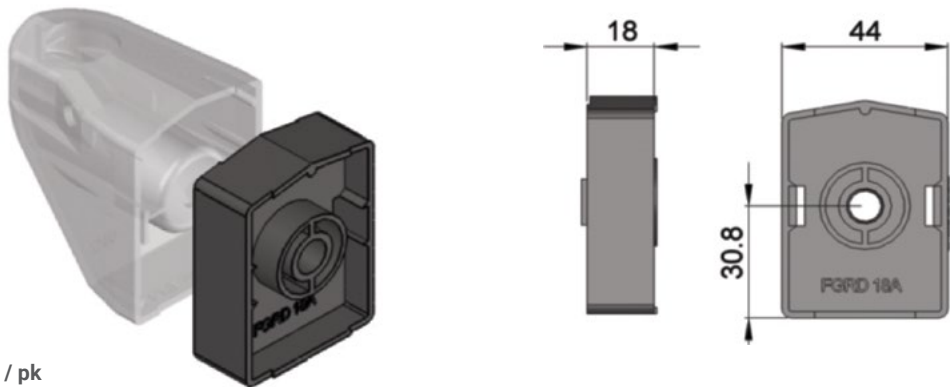

UOM: 10 pcs / pk

**SGRB-40x18** Guide Rail Bracket, D = 18mm - Polyamide

Stainless Steel Screw and Nuts

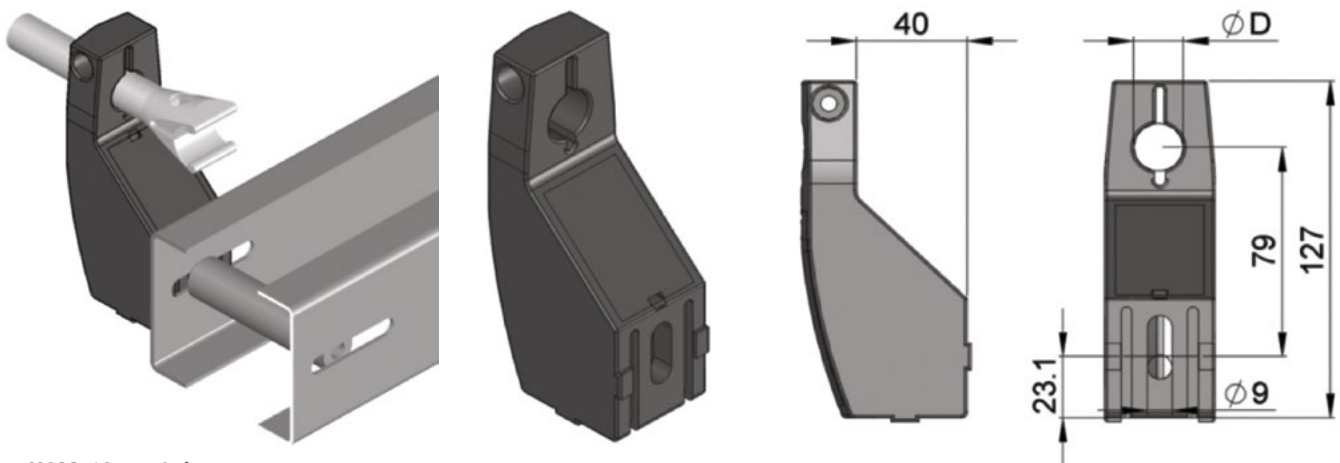

UOM: 10 pcs / pk



**FGRD-6B** Spacer for SGRB-40x18, SGRB-40x20 - Polyamide

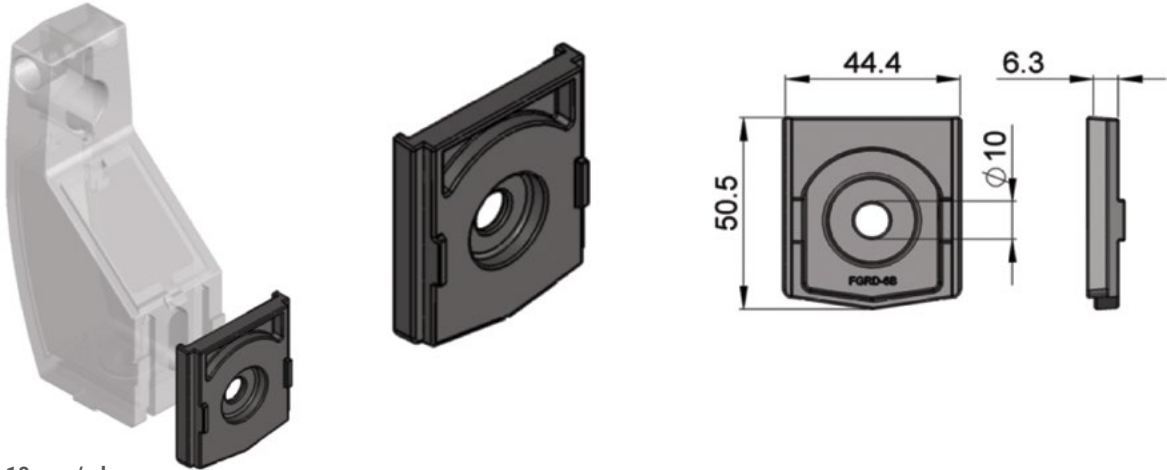

UOM: 10 pcs / pk

**SGRB-18x18** Guide Rail Bracket,  $\phi A = 18\text{mm}$ ,  $\phi B = 18\text{mm}$  - Polyamide

Stainless Steel Screw and Nuts

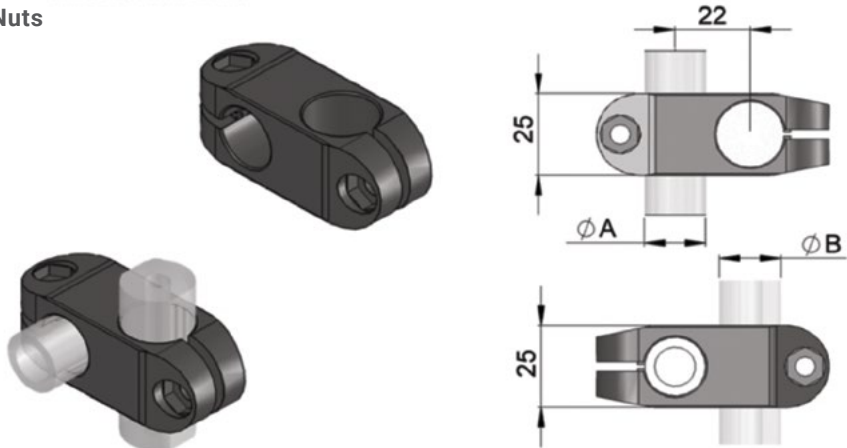

UOM: 10 pcs / pk

**SGRX-18X20** 90° Corner Connector - Polyamide

Stainless Steel Screw and Nuts

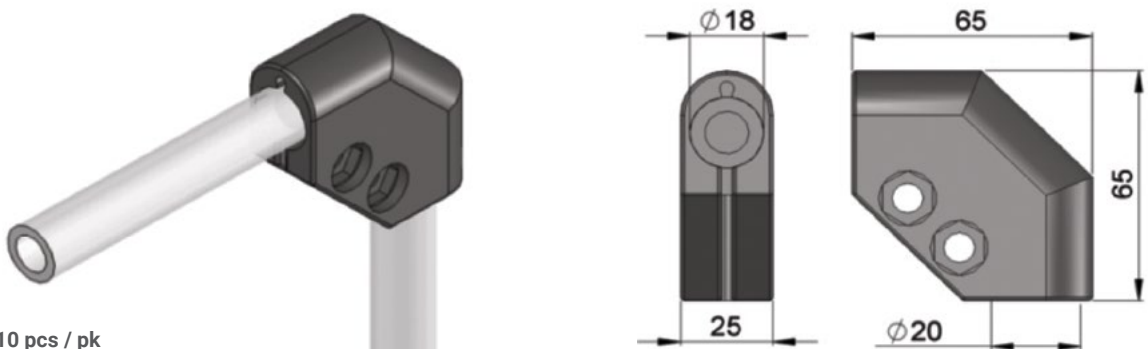

UOM: 10 pcs / pk

**Direct Mount, SEW Equivalent, Fixed Speed - 20 mm Shaft**

**230/460V 60 Hz**

- Sealed Gearmotor
- SEW SA37 Size gearmotor
- Totally enclosed fan cooled
- 230/460V 3 Phase
- 60 Hz
- Wiring by others

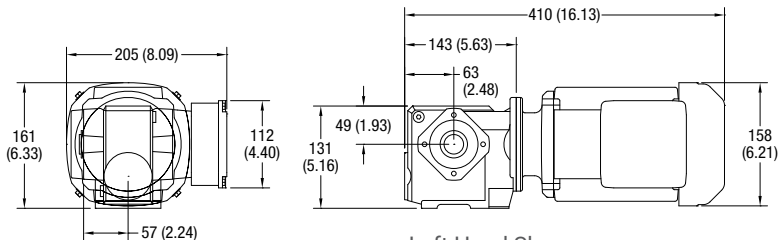

**Regulatory Approvals**



Part Number	Chain Speed				RPM	Hp	kW	Amps	in.-lbs.	Nm	Starter Chart Page 69
	SS, SM, SU, SV		SC								
	Ft/min	M/min	Ft/min	M/min							
FMM129(X)DS423EN	17.1	5.2	18	5.5	13	0.25	0.18	1.1/0.56	837	95	L
FMM067(X)DS423EN	32.8	10	34.8	10.6	25	0.5	0.37	1.9/0.95	699	79	M
FMM032(X)DS423EN	69.9	21.3	73.8	22.5	53	0.75	0.55	2.7/1.35	653	74	M
FMM015(X)DS423EN	150.3	45.8	158.5	48.3	114	0.75	0.55	2.7/1.35	341	39	M
FMM013(X)DS423EN	171.3	52.2	180.8	55.1	130	1	0.75	3.1/1.57	425	48	P
FMM010(X)DS423EN	225.4	68.7	237.9	72.5	171	1.5	1.1	4.2/2.1	490	56	P

Where (X) is L or R for Right Hand or Left Hand Gearmotor matching RH or LH Drive

**230/400V 50 Hz**

- Sealed Gearmotor
- SEW SA37 Size gearmotor
- Totally enclosed fan cooled
- 230/400V 3 Phase
- 50 Hz
- Wiring by others

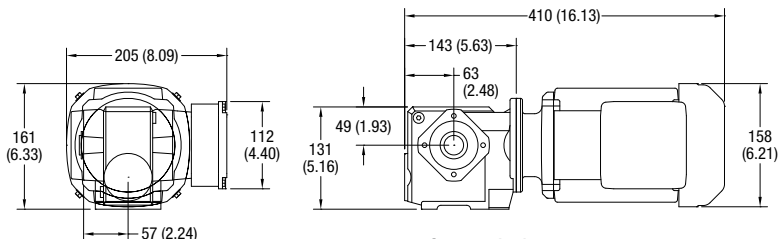

**Regulatory Approvals**



Part Number	Chain Speed				RPM	Hp	kW	Amps	in.-lbs.	Nm	Starter Chart Page 69
	SS, SM, SU, SV		SC								
	Ft/min	M/min	Ft/min	M/min							
FMZ099(X)DS423EN	17.1	5.2	18	5.5	13	0.33	0.25	1.3/0.76	628	71	I
FMZ060(X)DS423EN	30.2	9.2	31.8	9.7	23	0.5	0.37	1.9/1.09	717	81	I
FMZ029(X)DS423EN	63.3	19.3	66.6	20.3	48	0.75	0.55	2.6/1.52	478	54	I
FMZ013(X)DS423EN	137.1	41.8	144.7	44.1	104	1	0.75	3.1/1.79	363	41	J
FMZ009(X)DS423EN	205.7	62.7	213.9	66.1	156	1.5	1.1	4.1/2.38	336	38	J
FMZ007(X)DS423EN	284.8	86.8	300.5	91.60	216	2	1.5	5.6/3.23	372	42	N/A

Where (X) is L or R for Right Hand or Left Hand Gearmotor matching RH or LH Drive

SEW gearmotors are products of SEW Eurodrive

**CE Note:** When buying a gearmotor only without the starter, the customer must supply their own on/off switch and motor overload protection to comply with the CE Safety Directive.

**FLA = Full Load Amperes** Some motors and gear reducers may normally operate hot to the touch. Consult factory for specific operating temperatures. **Note:** Dimensions = mm (in)

**Direct Mount, SEW Equivalent, Variable Speed - 20 mm Shaft**

**230/460V 60 Hz**

- Sealed Gearmotor
- SEW SA37 Size gearmotor
- Totally enclosed fan cooled
- 230/460V 3 Phase
- 60 Hz
- Wiring by others

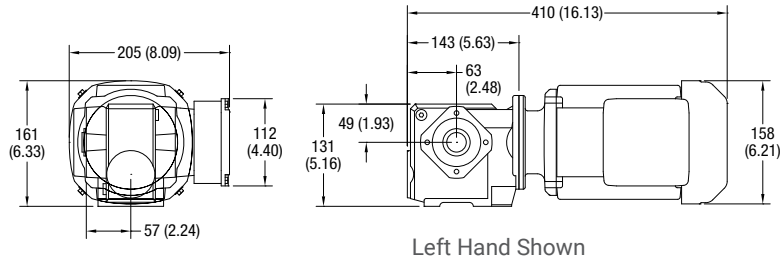

Regulatory Approvals



Part Number	Chain Speed				RPM	Hp	kW	Amps	in.-lbs.	Nm	VFD Chart Page 68
	SS, SM, SU, SV		SC								
	Ft/min	M/min	Ft/min	M/min							
FMM129(X)DS423EN	2.9 - 17.1	0.9 - 5.2	3 - 18	0.9 - 5.5	13	0.25	0.18	1.1/0.56	837	95	D
FMM067(X)DS423EN	5.5 - 32.8	1.7 - 10	5.8 - 34.8	1.8 - 10.6	25	0.5	0.37	1.9/0.95	699	79	D
FMM032(X)DS423EN	11.7 - 69.9	3.6 - 21.3	12.3 - 73.8	3.8 - 22.5	53	0.75	0.55	2.7/1.35	653	74	D
FMM015(X)DS423EN	25.1 - 150.3	7.6 - 45.8	26.4 - 158.5	8.1 - 48.3	114	0.75	0.55	2.7/1.35	341	39	D
FMM013(X)DS423EN	28.6 - 171.3	8.7 - 52.2	30.1 - 180.8	9.2 - 55.1	130	1	0.75	3.1/1.57	425	48	D
FMM010(X)DS423EN	37.6 - 225.4	11.5 - 68.7	39.7 - 237.9	12.1 - 72.5	171	1.5	1.1	4.2/2.1	490	56	D

Where (X) is L or R for Right Hand or Left Hand Gearmotor matching RH or LH Drive

**230/400V 50 Hz**

- Sealed Gearmotor
- SEW SA37 Size gearmotor
- Totally enclosed fan cooled
- 230/400V 3 Phase
- 50 Hz
- Wiring by others

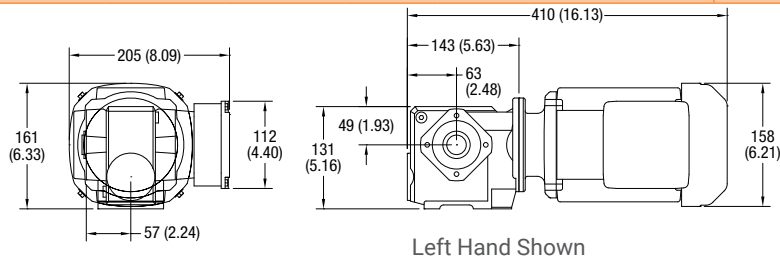

Regulatory Approvals



Part Number	Chain Speed				RPM	Hp	kW	Amps	in.-lbs.	Nm	VFD Chart Page 68
	SS, SM, SU, SV		SC								
	Ft/min	M/min	Ft/min	M/min							
FMZ099(X)DS423EN	3.4 - 17.1	1 - 5.2	3.6 - 18	1.1 - 5.5	13	0.33	0.25	1.3/0.76	628	71	B
FMZ060(X)DS423EN	6 - 30.2	1.8 - 9.2	6.4 - 31.8	1.9 - 9.7	23	0.5	0.37	1.9/1.09	717	81	B
FMZ029(X)DS423EN	12.7 - 63.3	3.9 - 19.3	13.3 - 66.6	4.1 - 20.3	48	0.75	0.55	2.6/1.52	478	54	B
FMZ013(X)DS423EN	27.4 - 137.1	8.4 - 41.8	28.9 - 144.7	8.8 - 44.1	104	1	0.75	3.1/1.79	363	41	B
FMZ009(X)DS423EN	41.1 - 205.7	12.5 - 62.7	43.4 - 213.9	13.2 - 66.1	156	1.5	1.1	4.1/2.38	336	38	B
FMZ007(X)DS423EN	57 - 284.8	17.4 - 86.8	60.1 - 300.5	18.3 - 91.60	216	2	1.5	5.6/3.23	372	42	B

Where (X) is L or R for Right Hand or Left Hand Gearmotor matching RH or LH Drive

SEW gearmotors are products of SEW Eurodrive

**CE Note:** When buying a gearmotor only without the starter, the customer must supply their own on/off switch and motor overload protection to comply with the CE Safety Directive.

**FLA = Full Load Amperes** Some motors and gear reducers may normally operate hot to the touch. Consult factory for specific operating temperatures. **Note:** Dimensions = mm (in)

**Variable Speed Controllers**

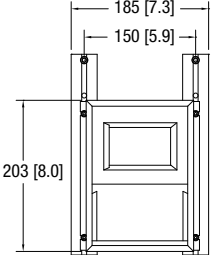
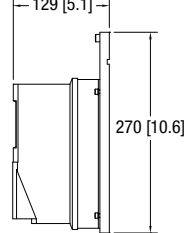
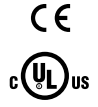
Chart B	VFD Controller, Full CE Compliance, 50 Hz							
<ul style="list-style-type: none"> <li>• VFD control</li> <li>• IP 65 enclosure</li> <li>• EMC filter</li> <li>• Variable speed</li> <li>• Mounting hardware</li> <li>• Line cord and motor cord</li> <li>• Motor cord only on 460V</li> </ul>					<p style="color: #f4a460;">Regulatory Approvals</p> 			

Part Number	Input Volts	Input Phase	Input Hz	Output Volts	Output Phase	Max Kw*	Max Amps	Reversing
62UV2121	230	1	50	230	3	0.75	4.2	Yes
62UV4341	400	3	50	400	3	0.75	2.1	Yes
62UV2127	230	1	50	230	3	1.50	6.8	Yes
62UV4347	400	3	50	400	3	1.50	3.4	Yes

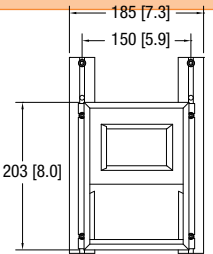
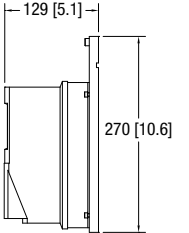
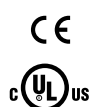
Chart D	VFD Controller, 60 Hz							
<ul style="list-style-type: none"> <li>• Full feature VFD control</li> <li>• NEMA 4 enclosure</li> <li>• Digital display</li> <li>• Keypad with Start/Stop, Forward/Reverse and speed variations</li> <li>• Includes cord to motor</li> <li>• Power to controller by others</li> <li>• 62MV1122 includes line cord to controller</li> <li>• Mounting hardware</li> </ul>					<p style="color: #f4a460;">Regulatory Approvals</p> 			

Part Number	Input Volts	Input Phase	Input Hz	Output Volts	Output Phase	Max Hp	Output Amps*	Reversing
32MV1122	115	1	60	230	3	0.5	2.2	Yes
32MV2122	230	1	60	230	3	0.5	2.2	Yes
32MV1121	115	1	60	230	3	1.0	4.0	Yes
32MV2121	230	1	60	230	3	1.0	4.0	Yes
32MV2127	230	1	60	230	3	2.0	6.8	Yes
32MV2322	230	3	60	230	3	0.5	2.2	Yes
32MV2327	230	3	60	230	3	2.0	6.8	Yes
32MV4341	460	3	60	460	3	1.0	2.0	Yes
32MV4347	460	3	60	460	3	2.0	3.4	Yes

In order for this drive to meet full CE requirements for European application a separate CE approve RFI filter must be installed. Product shown in chart B above have this filter pre-installed and are recommended for use in the European Union.

SEW gearmotors are products of SEW Eurodrive

**CE Note:** When buying a gearmotor only without the starter, the customer must supply their own on/off switch and motor overload protection to comply with the CE Safety Directive.

**FLA = Full Load Amperes** Some motors and gear reducers may normally operate hot to the touch. Consult factory for specific operating temperatures. **Note:** Dimensions = mm (in)

## Manual Motor Starters

Manual motor starts are manual electronic disconnects that provide motor overload protection and are required by the National Electric Code (NEC) for safe motor operation.

- IP 55 Enclosure
- Push button Start / Stop
- Includes mounting hardware

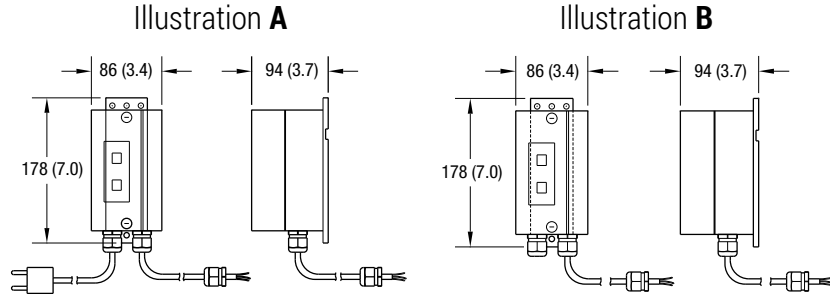

Chart I		230/400V 50Hz to 2.5 amp		
<ul style="list-style-type: none"> <li>• 230 Volts, 1 phase includes cord, plug and starter</li> <li>• 230/400 Volts, 3 phase wiring to starter by others</li> <li>• Wiring between motor and starter provided when ordered together</li> <li>• 50 Hz</li> </ul>				
Part Number	In Volts	In Phase	Amp Range	Illustration
62(c)M21T	230	1	1.6 - 2.5	A
62(c)M23T	230	3	1.0 - 1.6	B
62(c)M43T	400	3	0.63 - 1.0	B

Chart J		230/400V 50 Hz to 4 amp		
<ul style="list-style-type: none"> <li>• 230 Volts, 1 phase includes cord, plug and starter</li> <li>• 230/400V, 3 phase wiring to starter by others</li> <li>• Wiring between motor and starter provided when ordered together</li> <li>• 50 Hz</li> </ul>				
Part Number	In Volts	In Phase	Amp Range	Illustration
62(c)M21J	230	1	2.5 - 4.0	A
62(c)M23J	230	3	1.6 - 2.5	B
62(c)M43J	400	3	1.0 - 1.6	B

Chart L		230/460V 60 Hz to 1.6 amp		
<ul style="list-style-type: none"> <li>• 230/460 Volts, 3 phase wiring to starter by others</li> <li>• Wiring between motor and starter provided when ordered together</li> <li>• 60 Hz</li> </ul>				
Part Number	In Volts	In Phase	Amp Range	Illustration
62MM23L	230	3	1.0 - 1.6	B
62MM43L	460	3	0.4 - .63	B

Chart M		230/460V 60Hz to 2.5 amp		
<ul style="list-style-type: none"> <li>• 230/460 Volts, 3 phase wiring to starter by others</li> <li>• Wiring between motor and starter provided when ordered together</li> <li>• 60 Hz</li> </ul>				
Part Number	In Volts	In Phase	Amp Range	Illustration
62MM23M	208-230	3	1.6 - 2.5	B
62MM43M	460	3	1.0 - 1.6	B

Chart P		230/460V 60Hz to 4 amp		
<ul style="list-style-type: none"> <li>• 230/460 Volts, 3 phase wiring to starter by others</li> <li>• Wiring between motor and starter provided when ordered together</li> <li>• 60 Hz</li> </ul>				
Part Number	In Volts	In Phase	Amp Range	Illustration
62MM23U	208-230	3	2.5 - 4.0	B
62MM43P	460	3	1.6 - 2.5	B

Chart Q		230/460V 60Hz to 6.3 amp		
<ul style="list-style-type: none"> <li>• 230/460 Volts, 3 phase wiring to starter by others</li> <li>• Wiring between motor and starter provided when ordered together</li> <li>• 60 Hz</li> </ul>				
Part Number	In Volts	In Phase	Amp Range	Illustration
62MM23Q	208-230	3	4.0 - 6.3	B
62MM43Q	460	3	2.5 - 4.0	B

**CE Note:** When buying a gearmotor only without the starter, the customer must supply their own on/off switch and motor overload protection to comply with NEC and CE safety directive.

(c) = Electrical Configuration    G = CE German  
 F = CE French    U = CE Great Britain    **Note:** Dimensions = mm (in)



**Regulatory Approvals:**







**Conveyors:**

All Dorner FlexMove Series standard conveyors (not including gearmotors and controllers) are CE approved. CE approval follows the provisions of the following directives; Machine Directive 2006/42/EC, EU Low Voltage Directive 2006/95/EC, and EMC Directive 2004/108/EC. All conveyors are marked with the CE symbol on the Dorner serial number tag located on the conveyor frame. Contact the factory for the CE Declaration of Conformity.

All Dorner FlexMove Series standard conveyors (not including gearmotors and controllers) are designed and manufactured in accordance with the restrictions defined in the “Restriction of Hazardous Substances” directive, citation 2011/65/EU, commonly known as RoHS. All conveyors are marked with the RoHS symbols on the Dorner serial number tag located on the conveyor frame.

**Gearmotors and Controllers:**

All Dorner FlexMove Series gearmotors and controllers carry one or more of the following approvals. Products are not covered by each approval. Please see the appropriate part number on the Gearmotor and controller charts located in this manual. In addition, regulatory symbols are located on the product information tags located on the product.

	<p>CE Marking on a product is a manufacturer's declaration that the product complies with the essential requirements of the relevant European health, safety and environmental protection legislation, in practice by the Product Directives. CE Marking on a product ensures the free movement of the product within the European Union (EU).</p>
	<p>This directive restricts (with exceptions) the use of six hazardous materials in the manufacture of various types of electronic and electrical equipment. It is closely linked with the Waste Electrical and Electronic Equipment Directive (WEEE) 2002/96/EC which sets collection, recycling and recovery targets for electrical goods and is part of a legislative initiative to solve the problem of huge amounts of toxic e-waste.</p>
	<p>The UL Recognized Component mark is for products intended to be installed in another device, system or end product. This Recognized Component Mark is for the United States only. When a complete product or system containing UL Recognized Components is evaluated, the end-product evaluation process can be streamlined.</p>
	<p>The UL Recognized Component mark is for products intended to be installed in another device, system or end product. This Recognized Component Mark is for the United States and Canada. When a complete product or system containing UL Recognized Components is evaluated, the end-product evaluation process can be streamlined.</p>
	<p>CSA International (Canadian Standards Association), is a provider of product testing and certification services for electrical, mechanical, plumbing, gas and a variety of other products. Recognized in the U.S., Canada and around the world, CSA certification marks indicate that a product, process or service has been tested to a Canadian or U.S. standard and it meets the requirements of an applicable CSA standard or another recognized document used as a basis for certification.</p>
	<p>The UL Listing Mark means UL found that representative product samples met UL's safety requirements. These requirements are primarily based on UL's own published standards for safety. The C-UL-US Mark indicates compliance with both Canadian and U.S. requirements. The products with this type of Mark have been evaluated to Canadian safety requirements and U.S. safety requirements.</p>

## Clean Room Certifications:

FlexMove Conveyors are often used in clean room applications where the generation of particulates from the conveyor are a concern. In these applications the correct installation and application of the conveyor is critical to the proper running of the conveyor and minimizing the dust generated by the conveyor belt or modular belt. The end user must ensure that the conveyor belts are properly tracked and product accumulation is minimized to providing minimal dust generation.

All of the FlexMove products are designed and constructed to be used in clean room environments. The following FlexMove Series products have gone through third party testing and certification and are certified for use in ISO Standard 14644-1 Class 5 and Federal Standard 209 Class 100 Clean Room applications.

**1100 Series Belted Conveyor**

**FlexMove Series Flexible Chain Conveyor**

**FlexMove Stainless Series Conveyor**

**2200 Series Modular Belted Conveyor**

**2200 Series Belted Conveyor**

**2200 Series Precision Move Conveyor**

**3200 Series Belted Conveyor**

**3200 Series Modular Belted Conveyor**

**3200 Series Precision Move Conveyor**



Contact the factory for copy of the certification.

**Slide Rail Specifications / Application Data**

Part No.	FASR-25 FASR-25K	FASR-25U	FASR-25CD	FASR-25T	FASR-25P	FASR-25X
Material	HDPE	UHMW	Antistatic HDPE	PAPE	PVDF	Impregnated UHMW
Color	white	white	black	Grey	White	Blue
FDA approved	Yes	Yes	No	No	No	Yes
Coefficient of Friction	0.25	0.25	0.25	0.3	0.35	0.25
Temp Range	-20 to 60 C	-20 to 60 C	-20 to 60 C	-20 to 80 C	-20 to 100 C	-20 to 60 C
Maximum Speed	50 M/min	60 M/min	50 M/min	60 M/min	60 M/min	60 M/min
Heavy Loads	poor	good	poor	excellent	excellent	good
Elongation / wear resistance	poor	good	poor	excellent	excellent	good
Chemical Resistance	Good, poor to petroleum based solvents	Good	Good, poor to petroleum based solvents	Good, not used with wet solvents	Excellent	Good
Application	General conveyance, lowest cost	High speed, moderate loads, low dust generation	Environments sensitive to static electricity	High speed, high load, dry applications only, abrasive particles	High speed, high load, abrasive particles	High speed, moderate loads, low dust generation

## Chains

Series	SS	SM	SC	SU	SV
<i>Chain width (mm)</i>	63 mm	83 mm	103 mm	175 mm	255 mm
<i>Chain width (inch)</i>	2.48"	3.27"	4.06"	6.890"	10.039"
<i>Tensile strength at 20°C (N)</i>	3400 N	4800 N	4800 N	4800 N	4800 N
<i>Tensile strength at 68°F (lbf)</i>	764 lbf	1079 lbf	1079 lbf	1079 lbf	1079 lbf
<i>Max. working tensile at 20°C (N)</i>	500 N	1250 N	1250 N	1250 N	1250 N
<i>Max. working tensile at 68°F (lbf)</i>	112 lbf	281 lbf	281 lbf	281 lbf	281 lbf
<i>Working temperature (°C)</i>	-20 – 60°C	-20 – 60°C	-20 – 60°C	-20 – 60°C	-20 – 60°C
<i>Working temperature (°F)</i>	-4 – 140°F	-4 – 140°F	-4 – 140°F	-4 – 140°F	-4 – 140°F
<i>Maximum conveyor speed (m/min)</i>	58 m/min	58 m/min	58 m/min	58 m/min	58 m/min
<i>Maximum conveyor speed (ft/min)</i>	190 ft/min	190 ft/min	190 ft/min	190 ft/min	190 ft/min
<i>Max. conveyor length (m)</i>	30 m	30 m	30 m	30 m	30 m
<i>Max. conveyor length (ft)</i>	100 ft	100 ft	100 ft	100 ft	100 ft
<i>Min. turning radius (mm)</i>	150 mm	160 mm	170 mm	500 mm	700 mm
<i>Min. turning radius (inch)</i>	5.91"	6.30"	6.70"	19.7"	27.6"
<i>Link spacing (mm)</i>	25.4 mm	33.5 mm	35.5 mm	33.5 mm	33.5 mm
<i>Link spacing (inch)</i>	1.0"	1.32"	1.40"	1.32"	1.32"
<i>Chain weight (plain) (kg/m)</i>	0.75 kg/m	1.20 kg/m	1.67 kg/m	2.0 kg/m	2.43 kg/m
<i>Chain weight (plain) (lb/ft)</i>	0.50 lb/ft	0.81 lb/ft	1.12 lb/ft	1.344 lb/ft	1.633 lb/ft
<i>Max. weight on conveyor (kg/m)</i>	30 kg/m	60 kg/m	60 kg/m	65 kg/m	65 kg/m
<i>Max. weight on conveyor (lb/ft)</i>	20 lb/ft	40 lb/ft	40 lb/ft	44 lb/ft	44 lb/ft
<i>Item width (mm)</i>	15-140 mm	20-200 mm	25-300 mm	50-400 mm	80 – 500 mm
<i>Item width (inch)</i>	0.6 – 5.5"	0.8-7.9"	1.0-11.8"	2.0 – 15.4"	3.2 – 19.7"

## Drive Unit Specifications

### Direct Drive unit

	SS	SM	SC	SU	SV
Number of Teeth on sprocket	16	12	12	12	12
Chain Pitch (mm)	25.4	33.5	35.5	33.5	33.5
Max. Traction force (N)	500	1250	1250	1250	1250
Sprocket Diameter (mm)	128	128	135	128	128

### Stand Location

**Maximum Distances:**

1 = 914 mm (36 in)

2 = Should be between 1800-2400 mm (6-7.8 ft)\*

\* For conveyors longer than 3000 mm (10 ft), install support at joint.

Note: Additional support required on 180° curve modules.

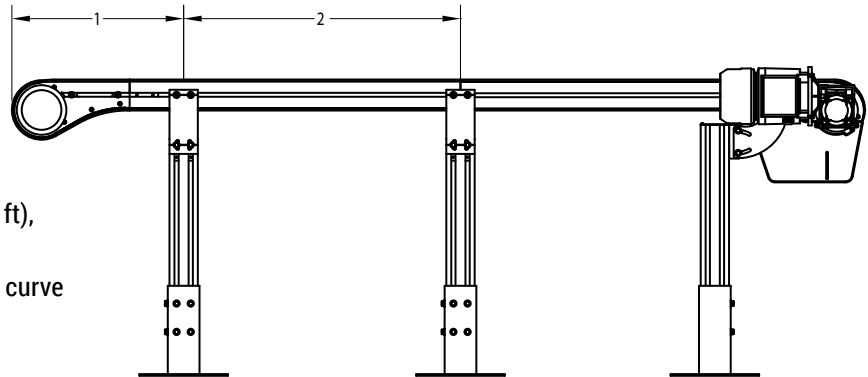

Support must be provided directly at drive end. See accessories for Direct Mount and Suspended Mount support options.

### Conveyor Drive Shaft Tolerances:

**Optional Auxiliary Shaft**

20 mm Shaft

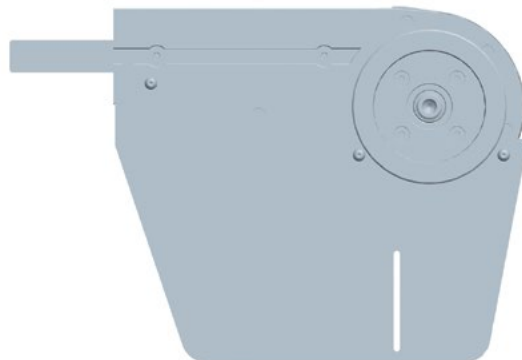
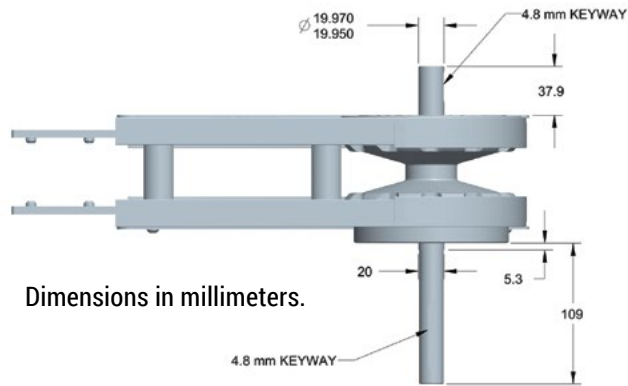



### Conveyor Load Capacity

There are several factors that affect the overall conveyor load of the FlexMove conveyor. These include:

- Conveyor size and configuration
- Conveyor speed
- Application temperature
- Product accumulation
- Number of starts and stops per hour
- Maximum Drive Unit Output

Located online at [www.dornerconveyors.com](http://www.dornerconveyors.com) is the Dorner conveyor configuration tool, DTools. This tool allows you to configure your conveyor layout and determine the maximum load capacity for the conveyor. It is suggested that this program be used to calculate the conveyor load as the calculation is quite complicated. This configuration program however does not take into account temperature, dirty conditions, and conveyor starts and stops. If these conditions are part of your application, please use the load reducing factors as shown below.

**Maximum Load = (Load from DTools) (Temperature Factor) (Start/Stop Factor)**

See following pages for factors.

### Nominal Maximum Load

A Nominal Maximum Load may be calculated without the use of DTools to determine if the conveyor can generally carry the application load. The following process can be used to calculate Nominal Maximum Load. It **does not** take into account the conveyor configuration. Please confirm your maximum load per application with the Dorner DTools program at [www.dornerconveyors.com](http://www.dornerconveyors.com).

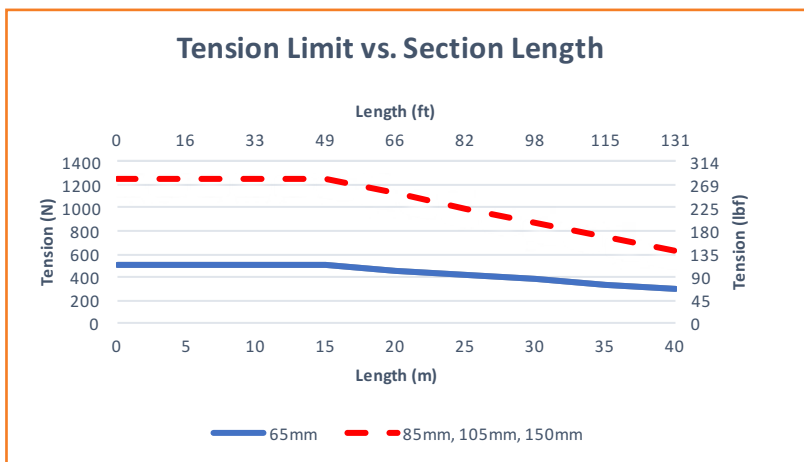
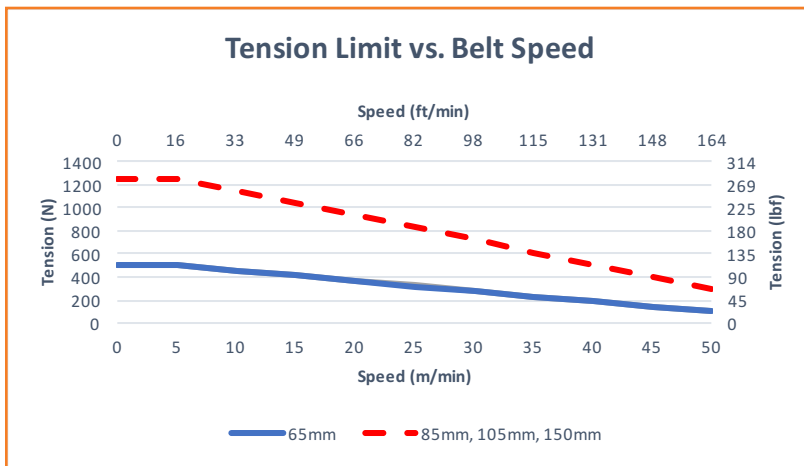

To calculate the Nominal Maximum Load:

*Note: This does not include conveyor configuration. Please confirm load with Dorner online DTools configurator.*

1. Determine your Basic Tension Limit from the above two graphs. The Basic Tension Limit is the lesser number of the two. Compare your tension limit to drive unit output. Your tension limit is the smaller.
2. Tension Limit = (Basic Tension Limit) (Temperature Factor) (Start/Stop Factor) (Accumulation Factor) (0.7)  
*See following pages for factors.*
3. Nominal Maximum Load (kg) = (Tension Limit / Chain Coefficient of Friction) - (Conveyor length) (2) (Chain weight)

**Nominal Maximum Load (lbs) = (Nominal Maximum Load (kg)) (2.2)**

See following pages for Chain Coefficient of Friction. Nominal Maximum load may also be limited by available gearmotors.

Conformation of gearmotor torque is required. See pages 66-67 for gearmotors available. Nominal Maximum load cannot exceed overall conveyor load limit of 300 lbs (136kg) for 65 mm wide and 600 lbs (273kg) for 105 mm and 150 mm wide.

**Nominal Maximum Load** *(continued)*

**Example:**

105 mm FlexMove by 20 meters total length running at 15 Meters/min. Accumulated load with dry metal parts running in a 40°C environment. Continuous running.

- Basic Tension Limit – Tension vs. Speed = 1050N
- Basic Tension Limit – Tension vs. Length = 1100N
- Therefore Basic Tension Limit = 1050N
- Tension Limit = (Basic Tension Limit) (Temperature Factor) (Start/Stop Factor) (Accumulation Factor) (0.7)
- Tension Limit = (1050) (0.9) (1.0) (0.5) (0.7) = 330N
- Nominal Maximum Load (kg) = (Tension Limit / Chain Coefficient of Friction) - (Conveyor length) (2) (Chain weight)
- Nominal Maximum Load (kg) = (330 / 0.3) - (20) (2) (16.4) = 1100 - 984 = 116 kg
- Nominal Maximum Load (lbs) = 116\*2.2 = 256 lbs

Temperature Factor		
Ambient temperature can negatively affect the tension capacity of the conveyor chain.		
Temperature (°F)	Temperature (°C)	Temperature Factor
-4	-20	1.0
32	0	1.0
68	20	1.0
104	40	0.9
140	60	0.8

Start / Stop Factor	
Frequent Start / Stops of the conveyor can negatively affect the tension capacity of the conveyor chain. All start / stop applications must use a soft start mechanism such as a Frequency Inverter with a 1 second acceleration cycle.	
Application Condition	Start / Stop Factor
Continuous Run or 1 start/stop per hour	1.00
Maximum 10 starts/stop per hour	0.83
Maximum 30 starts/stop per hour	0.70
Greater than 30 starts/stop per hour	0.62

Accumulation Factor		
Product accumulation greatly reduces the conveyor load capacity. Product accumulation may only be done with the plain chain. Based on the product being accumulated apply the below Accumulation Factor in determining your Nominal Maximum Load. All factors below are assuming dry conditions.		
Product Being Accumulated	Typical Coefficient of Friction	Accumulation Factor
Steel	0.25	0.50
Glass	0.20	0.60
Aluminum	0.25	0.50
Plastic	0.25	0.50
Wood	0.30	0.40
Paper and Cardboard	0.30	0.40

Chain Coefficient of Friction	
The following table provides the coefficient of friction between the standard UHMW wearstrips and the Acetal chain. Coefficient of friction as shown may be reduced by addition of a lubricant.	
Application Condition	Coefficient of Friction
Dry	0.30
Water Lubrication	0.27
Coolant Lubrication	0.20
Oil Lubrication	0.20

**Drive Unit Output Capacity, P(W) requirement depend on:**

- Traction force F (N)    • Chain speed V (m/min)

To calculate power, the equation is  $P = 1/60 (F \times V)$

There are several drive unit designs, the maximum permissible traction force on each type of drive unit as below:

Drive unit type	Maximum traction force in Newton (N)				
	SS	SM	SC	SU	SV
End	500	1250	1250	1250	1250

### Conveyor Noise Level

The actual noise level generated by the conveyor depends on several factors; the installation configuration, the product running on the conveyor, the surrounding equipment, the conveyor options and chain speed. The noise level generated by the conveyor is typically less than the general noise level of factory equipment.

Generally, a higher speed chain will result in a higher noise level. In addition, 65 mm conveyors will run slightly quieter, and power transfer tails will add a few decibel points as well. The following charts provide basic decibel ratings for typical conveyor arrangements, such as wheeled and plain bend corners, and power transfers.

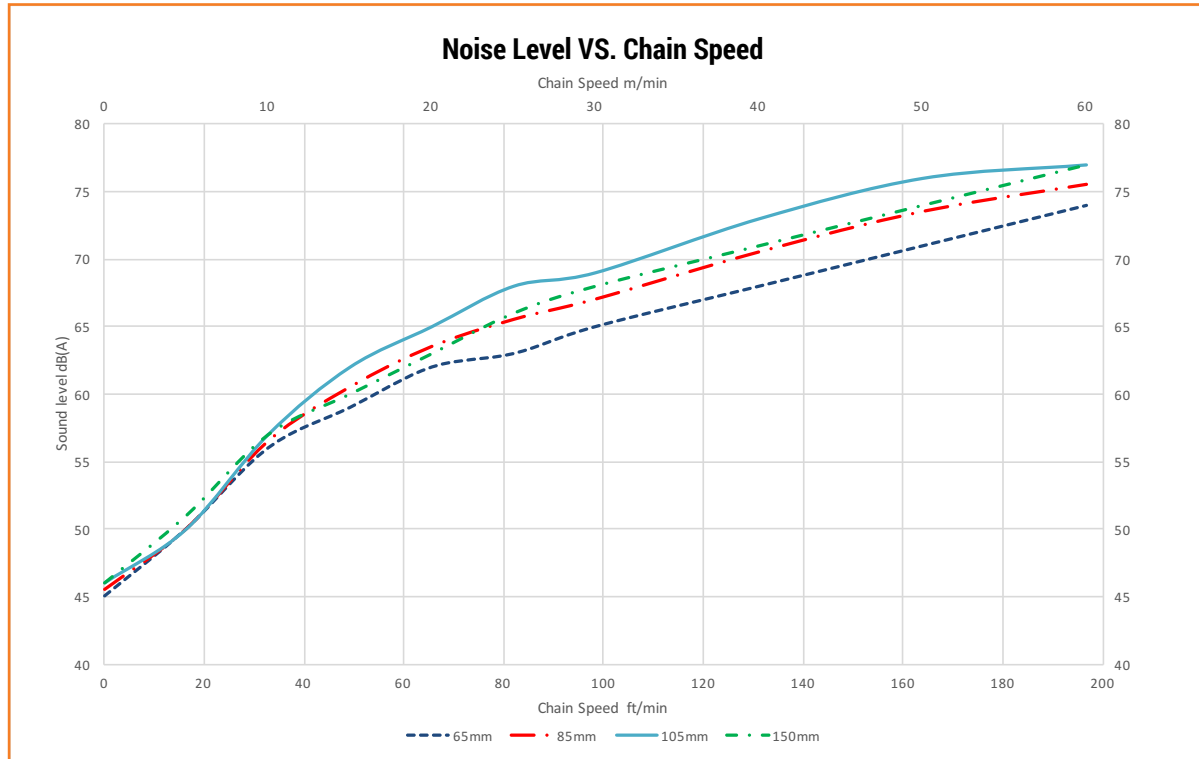

Decibel ratings are taken approximately 3 feet away from the conveyor modules.

## Bend Factors

Bend factors must be considered and calculated at every plain chain. It depends on the angle of the bend  $\alpha$  in radians and friction coefficient  $\mu$  between chain and slide rails. In application when conveyor is dry and clean, the friction coefficient  $\mu$  is close to 0.1.

The bend factor is important to calculate since the frictional force of a plain bend depends not only on the weight of chain and product but also the actual the tension throughout the bend. The result an additional pressure force of the chain towards the conveyor beam directed toward the center of the bend. Since the chain tension varies throughout the conveyor, calculation of this additional pressure force is complicated. The highest values are present at the pulling side of the drive unit and virtually zero at the chain inlet. Using bend factor is the easiest way of including added friction in the plain bend for both horizontal and vertical into the calculation. Always use wheel bend unless for exceptional cases. If using plain bend is a must, the combined plain bends angle should not more than 180°, unless it is for a very short and light application.

Bend type, horizontal or vertical plain bend	Bend factor $\alpha$
30°1	.2
45°	1.3
60°1	.4
90°1	.6

8° inclined is the maximum a product could convey for plain chain whereas friction top chain could take up to 30°

## Material

Material	FlexMove Parts
POM (PolyOxyMethylene)	Conveyor Chain, rollers
POM Conductive (PolyOxyMethylene)	Conductive chain
Aluminum, extruded & anodized	Angle bracket, beam support bracket, conveyor beam, support beam, guide rail, distance tube, fixed and adjustable side guide bracket, spacer
Steel, electro-zinc plated	Bolts and nuts, connecting strips, foot connecting strip
Steel, powder coated	Foot, connecting plate
PA, Polyamide	Chain pivot, side guide bracket, side guide support, drive and idler steering guide, end caps, wheel guide
Polyamide PA + Glass fiber	Drive sprocket, idler wheel
PVC, Polyvinyl Chloride	T-slot cover
HDPE, High Density Polyethylene	Slide rail, guide rail
UHMW-PE, Ultra High Molecular Weight Polyethylene	Slide Rail, drive and idler steering guides
PVDF, Polyvinylidene fluoride	Slide Rail
TPE, Thermoplastic Elastomer	Chain insert for friction top and wedge top

## Resistance to Chemical

FlexMove® components can withstand continuous contact with most chemicals. However, it is recommended to avoid:

- Acids with pH less than 4
- Bases with pH higher than 9

The following table specifies the resistance of several material used in the conveyor on selected chemicals

### Legend

1 = Very good

2 = Good

3 = Moderate resistance

4 = Not recommended

5 = No data available

Material	Acetal POM	Polyamide PA	High-density Polyethylene HDPE	Thermoplastic Elastomer TPE	Aluminum AL
<b>Acids:</b>					
Acetic acid	3	4	3	-	2
Benzoic acid	3	4	1	-	4
Citric acid	3	2	2	-	2
Chromic acid	4	4	1	-	3
Hydrofluoric acid	4	4	1	-	4
Hydrochloric acid	4	4	1	-	3
Hydro cyanic acid	4	4	2	-	1
Nitric acid	4	4	4	-	3
Phosphoric acid	4	4	1	-	3
Sulphuric acid	4	4	2	1	3
Tartaric acid	3	2	1	-	1
<b>Basic compounds:</b>					
Ammonia	1	2	1	-	2
Calcium hydroxide	1	2	1	-	4
Caustic soda	1	2	1	1	3
Potassium hydroxide	1	2	1	-	4
<b>Salts:</b>					
Potassium bicarbonate	2	2	2	-	1
Potassium permanganate	2	4	2	-	1
Sodium cyanic	2	2	2	-	4
Sodium hydrochloride	3	4	1	-	4
Acid salt	2	3	1	-	-
Basic salt	1	2	1	-	-
Neutral salt	1	2	1	-	-



### Chains

Material	Acetal POM	Polyamide PA	High-density Polyethylene HDPE	Thermoplastic Elastomer TPE	Aluminum AL
<b>Organic compounds and solvents:</b>					
Acetone	1	1	4	3	1
Benzene	1	1	4	3	1
Butyl alcohol	2	2	2	-	1
Carbon disulphide	1	1	3	-	1
Chloroform	1	1	4	-	-
Ethyl acetate	1	1	2	-	1
Ethyl alcohol	1	1	1	-	1
Heptane	2	2	2	-	-
Methyl alcohol	1	1	1	-	2
Methyl ethyl ketone	1	1	4	4	2
Nitrobenzene	2	2	3	-	1
Phenol	3	3	2	-	1
<b>Gasses:</b>					
Carbon dioxide	3	1	1	-	1
Carbon monoxide	2	1	1	-	1
Chlorine	2	4	3	-	1
Hydrogen sulphide	3	1	2	-	1
Sulphur dioxide	2	3	2	-	1
<b>Others:</b>					
Beer	1	2	2	-	1
Fruit juices	1	2	3	-	2
Gasoline	1	2	2	-	1
Milk	1	1	2	-	1
Oil	1	1	2	-	1
Vinegar	1	2	3	-	1

Note: the table above is valid for temperature range up to 60°C and it is to be considered as guideline only. Furthermore, precautions should be taken when using cleaning agents. If you are in doubt on the material to withstand your special environment, you should go for chemical testing or contact our local distributor.

### Static Electricity

The standard plastic materials used for conveyors have low electrical conductivity so static electricity can build up in the conveyor. When a conveyor is running under normal environment (20°C and humidity 60%) without load, the static electricity build up should be around the following figures:

Above the drive unit	1800-2500V
Idler end	400-500V
Above the wheel bend	400-500V
Above the straight section	250-350V

With the introduction of anti-static material for slide rail and chain, it shall meet the requirement for electronic industry.

## FlexMove<sup>®</sup> Stainless Steel Conveyors are best for:

- Part Handling
- Tight Spaces
- Buffering
- Elevation Changes
- Accumulation
- Long Lengths
- Complex Configurations
- Caustic & Corrosive Environments
- Curves, Jogs, Inclines, Declines

### Sizes & Measurements

- Widths: 65 mm, 85 mm, 105 mm, 180 mm and 260 mm
- Lengths: up to 30 m (98 ft)

### Loads & Speeds

- Loads up to 65 kg/m (44 lbs/ft)
- Speeds: up to 58 mpm (190 fpm)

### Plastic Chain Types

- Standard: Low Friction & Friction Top Inserts
- Specialty
  - Conductive
  - Cleated
  - Hardened Steel Top
  - Roller Top
  - Magnet Top
  - And Many More



Flat



Cleated



Friction Top

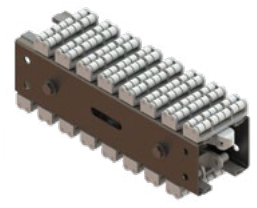

Roller Top

### Modules



Drive Tail



Idler Tail

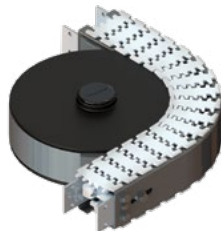

Curves from 15° to 180°



Inclines/Declines from 5° to 90°

### Support Stands

- Tripod Supports
- Horizontal & Adjustable Angle Supports also available



### Guiding

- Fully Adjustable
- Adjustable Width/Height
- Twin Rail
- Overhead Guide





**Industrial**



**Flexible Chain**



**Pallet Systems**



**Sanitary Stainless Steel**

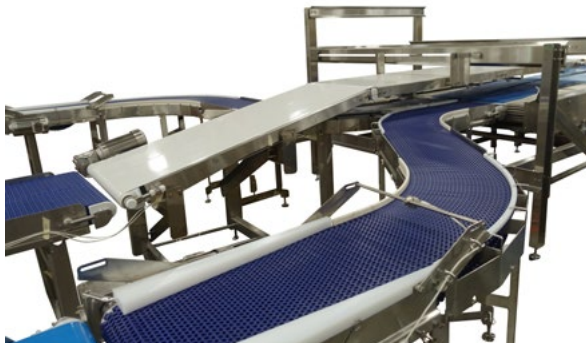

**Engineered Solutions Group**

Custom engineered solutions for almost any application.



**CAD Configurator Tool**

Industry leading tool! Configure your own custom conveyor in minutes.

# TRANSFORMING CONVEYOR AUTOMATION

## Contact Dorner

**United States**  
+1-262-367-7600

**Canada**  
+1-289-208-7306

**Mexico**  
+52.33.30037400

**Germany**  
+49 (0) 2461/93767-0

**France**  
+33 (0)1 84 73 24 27

**Malaysia**  
+604-626-2948



By Columbus McKinnon

**DORNERCONVEYORS.COM**



CONVEYANCE SOLUTIONS



MAGNETEK

montrate2

© Dorner Mfg. Corp. 2024. All Rights Reserved.