

# FlexMove Wedge Conveyor

## Standard Specials Spec Sheet

### INTRODUCTION TO WEDGE CONVEYORS

In most facilities, space is a premium, and conveyor location is often dependent on machinery and facility design. At Dorner, our goal is to simplify your processes rather than impede them. We have several solutions designed to give you more floor space and easy access to machinery and other areas of your facility.



Our Wedge Conveyors are used to take products from production floor level to a higher level or vice versa. Products are wedged between opposing conveyors aligned vertically or horizontally and are moved swiftly but securely.

Wedge Conveyors are easy to construct, lightweight and have compact footprints. Its rapid transfer rate makes it ideal for use in continuous, high capacity operations such as packaging lines. Built with aluminum or stainless steel, it meets the stringent hygiene standard required for medical and cosmetic packaging.

They can be configured differently for a variety of uses, such as a transition between different levels, de-pucking operations, inverted rinse operations, and even for creating a passage way on the production floor.

### HOW A WEDGE CONVEYOR WORKS

- Constructed with two parallel FlexMove conveyors utilizing a urethane gripper chain that wedge the sides of the product to lift or lower it vertically
- Products are fed into the Wedge Conveyor from a horizontal conveyor with at least a product length gap to avoid hitting each other while going through the vertical transition. Products then exit onto a horizontal conveyor
- Can be used with products of various sizes and shapes including boxes, totes, cans, plastic containers and bottles. Product must be able to withstand some side pressure
- Vertical transfer can be through a wheel corner or plain bend corner. Wheel corner is generally limited to product less than 100 mm in length
- Can be configured with a manual adjustable conveyor positioner for quick product size changeover. Various configurations can also change product orientation

### FlexMove Wedge Conveyor Configurations

Typical configurations for Wedge Conveyors form the following shapes - S, C, N (U) and O.



#### S Type Configuration

The product is elevated or lowered along a straight path. This is the most common wedge configuration.



#### C Type Configuration

The product is elevated or lowered while changing the orientation or flipping over the product.

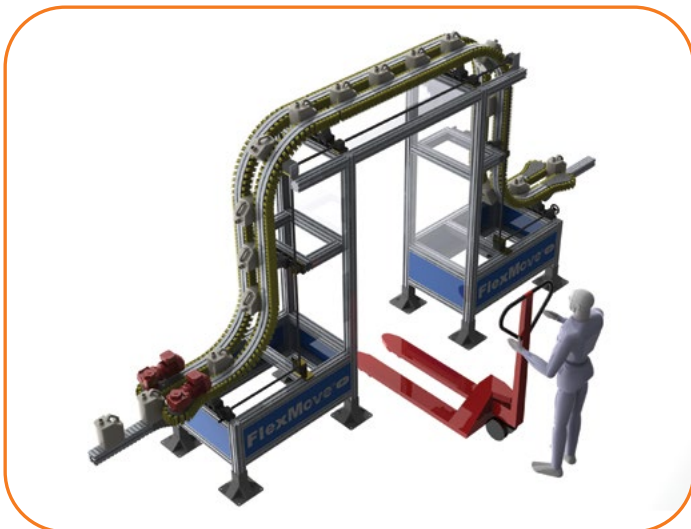

#### N (U) Type Configuration

The product is elevated and lowered (opposite for U shape) to allow for clearance below the conveyor. This clearance may be needed to allow for traffic through the conveyor or if there is another conveyor or piece of equipment to pass over.

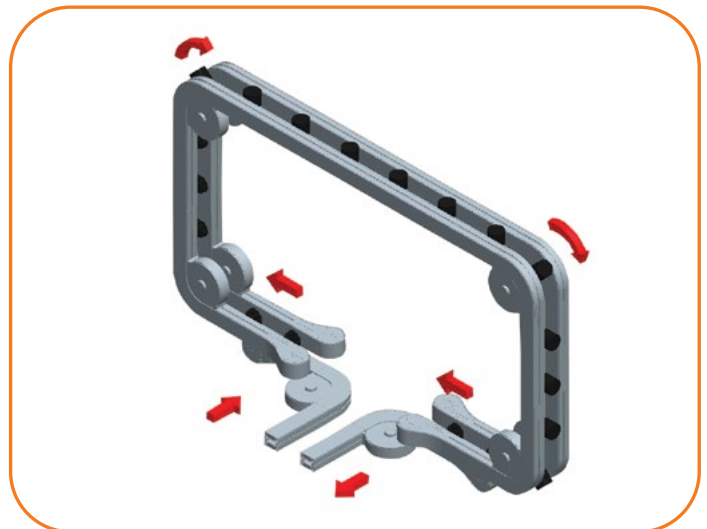

#### O Type Configuration

The product follows the loop, tipped upside down and conveyed back to near the infeed. This can be used to dry product, or to empty bottles/containers before the next process.

## Width Adjustment Actuator

If moving various size products width adjustments can be made using a manual mechanical adjustment system. The system is adjusted by a hand crank at one location that moves each side of the Wedge Conveyor equally about the centerline. System consists of adjustment actuator, angle gear units and connecting shafts.

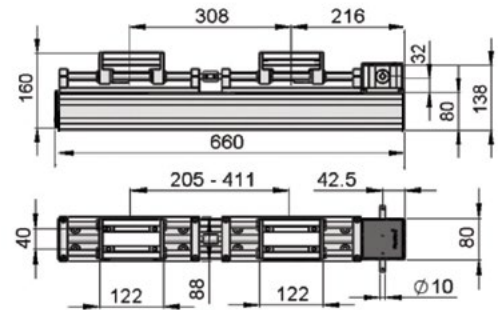

Width adjustment actuators are required at each mounting location.

## Angle Gear Units

Angle gear units connect actuators to move conveyor mounts together.

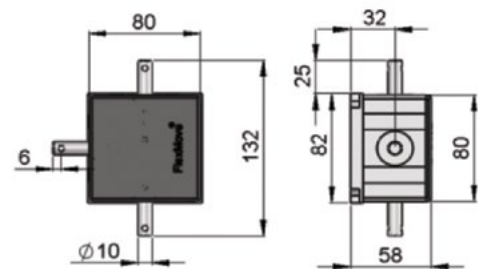

## Application Considerations:

### Product Size and Weight

Wedge Conveyors are ideal for transporting metal containers, plastic bottles, paper rolls, boxes or other products that can handle the pressure of the wedge. They are not suitable for wet or heavy products.

Individual product weight generally is less than 4.5 kg (10 lbs) each. However with very sturdy product this can be increased to 9 kg (20 lbs). See page 5 for the various chain types and the recommended product type for each. Total product weight on the Wedge Conveyor should not exceed 90 kg (200 lbs).

The width of the Wedge Conveyor is available in 45, 65 and 85 mm. Generally the edge width should be at least 1/3 of the height of the product. 85 mm wide wedge units should be used for larger weight/size products.

Products must be fed with at least a product length gap to avoid hitting each other while going thru the vertical transition.

Product height and length affect the wheel type and size to be used. The wheel bend radius is 160 mm. These are limited to small bottle's generally less than 51 mm (2 in) in diameter and 102 mm (4 in) tall.

For plain bend corners with a 500 mm radius which is most commonly used, will work best for product up to 457 mm (18 in) long and about 305 mm (12 in) tall.

For plain bend corners with a 700 mm radius, larger product over 457 mm (18 in) long can be transported.

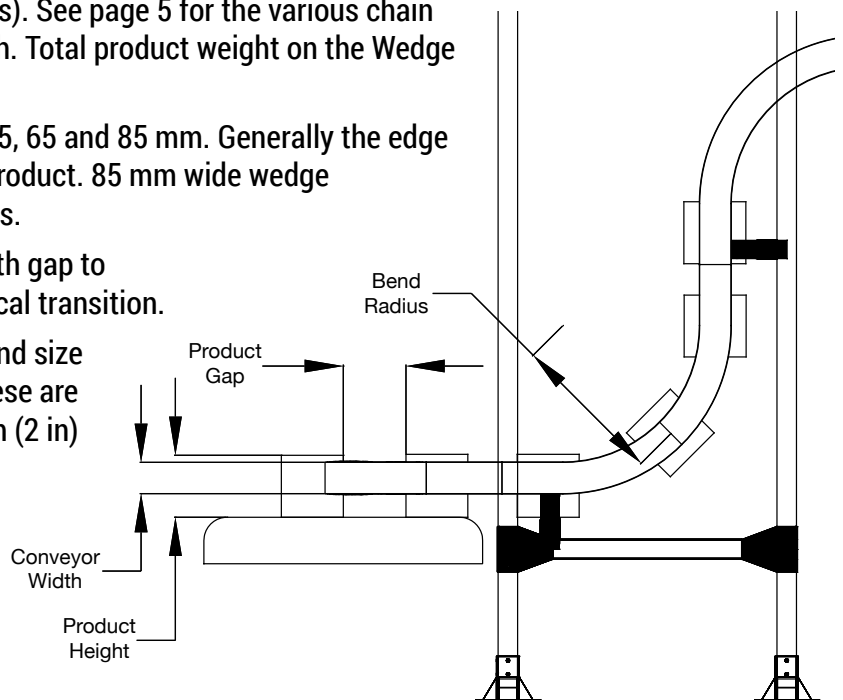

### Tall Products

Tall or tippy products need to be gently fed into the wedge and gently released from the Wedge to ensure they do not fall over. This is typical with products such as aerosol cans. To accomplish this, a 5° vertical bend is added to the infeed section and exit section as shown. This allows the grippers to gradually release the product.

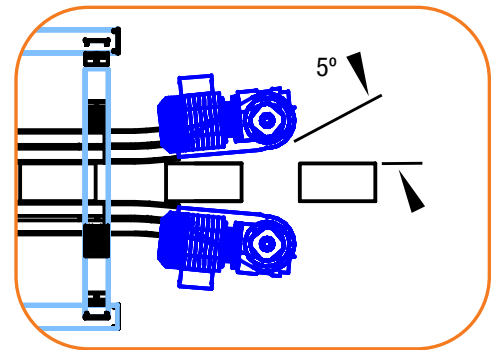

### Chain Type/Product Capability

Various Wedge finger types are available supporting different product types and weights.



Chain	Specifications	Description	Products
-5B	Rectangles, round and irregular shaped products up to 3kg (7 lbs)*	Heavy duty angled fingers	For firm grip of various products including irregular shapes
-5C	Rectangular shaped products up to 4.5kg (10 lbs)*	Heavy duty block wedges	Larger surface area for grabbing larger, heavier products
-5D	Rectangles, round and irregular shaped products up to 1.5 kg (3.5 lbs)*	Light duty angled fingers	Fingers gently grab lighter products or products that are not rigid surfaces

\*Weights shown are for 85 mm chain. Contact factory for 45 or 65 mm wedge applications.

### Chain

Wedge Top Chain **FMWT-5B**

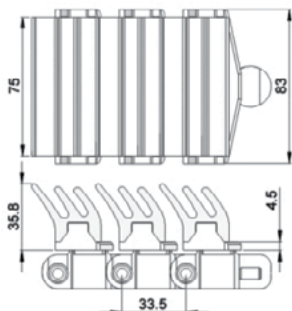
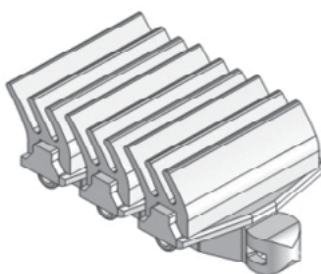

Wedge Top Chain **FMWT-5D**

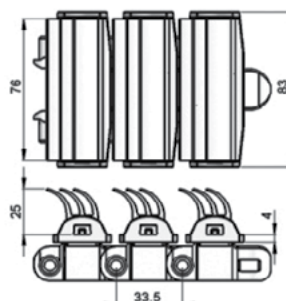
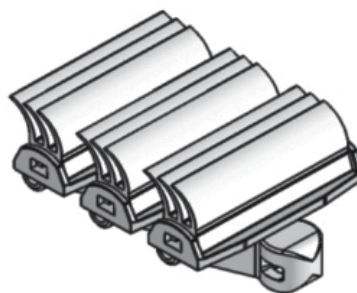

Wedge Top Chain **FMWT-5C**

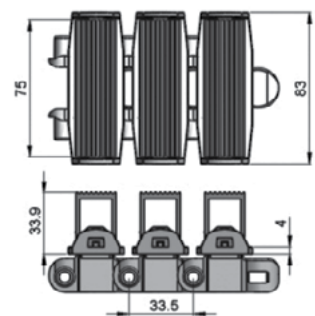
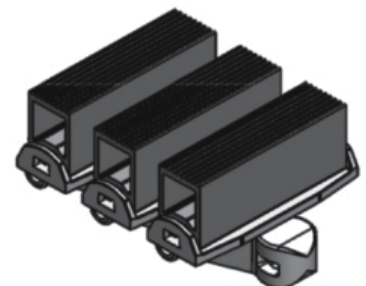

### Speed Control

The speed of the two opposing conveyors needs to be matched in order for the product to move smoothly through the conveyor. While precise speed matching is not needed, speed control should be done by using two motors with two variable frequency drives. Adjust the frequency to each one so the conveyors are as close in speed as possible. Measuring speed with a tachometer is suggested. Using one motor to drive the two conveyors with one variable frequency drive is also acceptable for speed matching the two conveyors.

### Wear Strip Selection

The pinching action of the wedge put higher loads on the conveyor wearstrip. UHMW-PE wearstrips (FASR-25U) should be used when ever possible. In extreme applications, special low friction, FASR-25X or PVDF, FASR-25P can also be used.

### General Specifications

45 mm, 65 mm and 85 mm

- Minimum lower height: 457 mm (18 in)
- Maximum upper height: 6096 mm (240 in)
- Maximum individual product weight: 4.6 kg (10 lbs)
- Maximum total weight: 90 kg (200 lbs)
- Speeds: Up to 52.2 m/min (171 ft/min)
- Slight variation in product size is compensated for by the flexible wedge fingers without having to adjust the conveyor

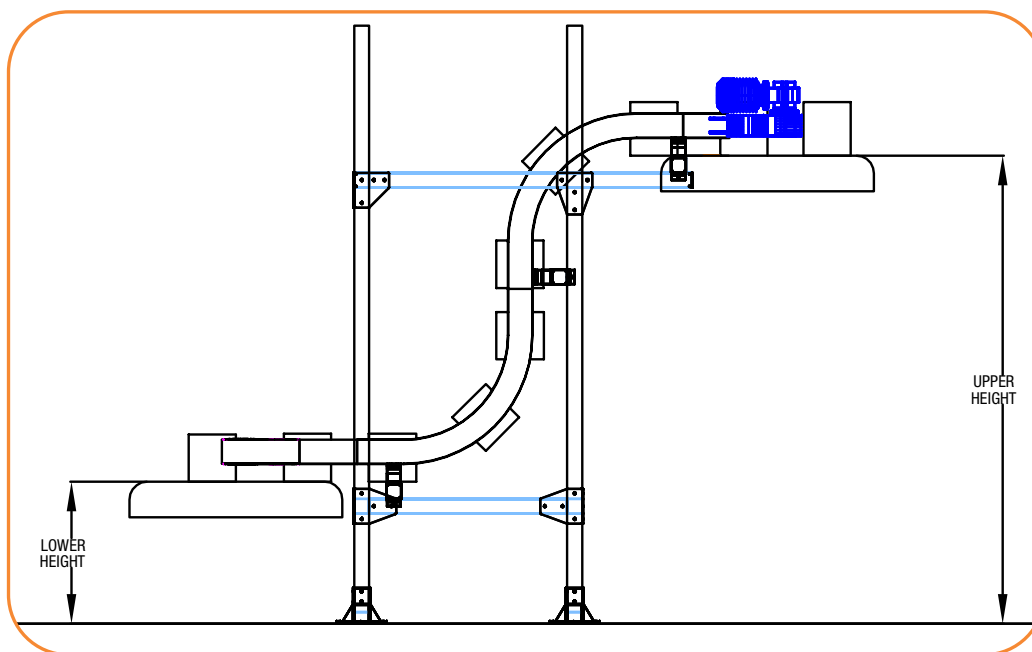
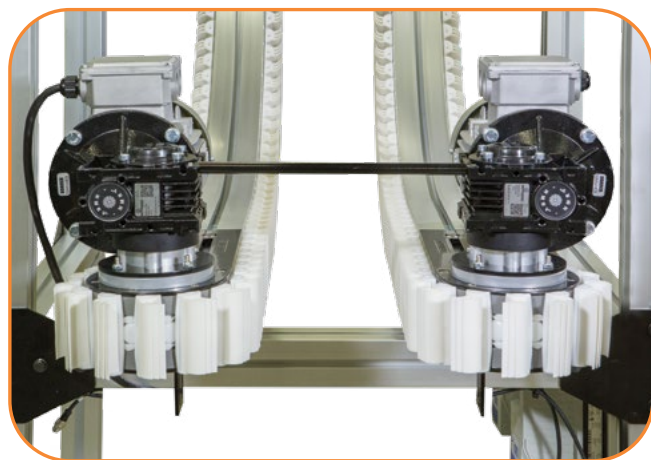

## Building Blocks of Wedge Conveyors

### Chain Examples

Wedge Top Chain **FMWT-5B**

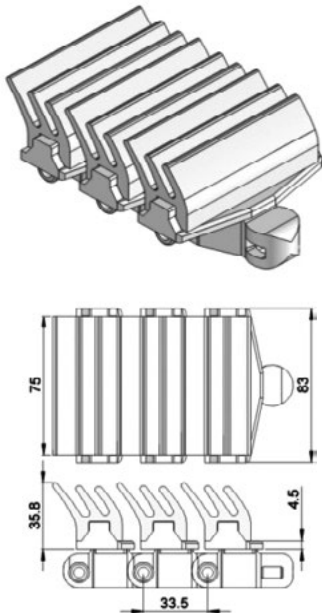

Wedge Top Chain **FMWT-5D**

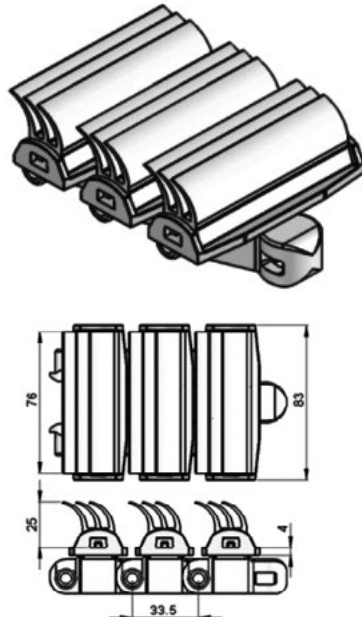

Wedge Top Chain **FMWT-5C**

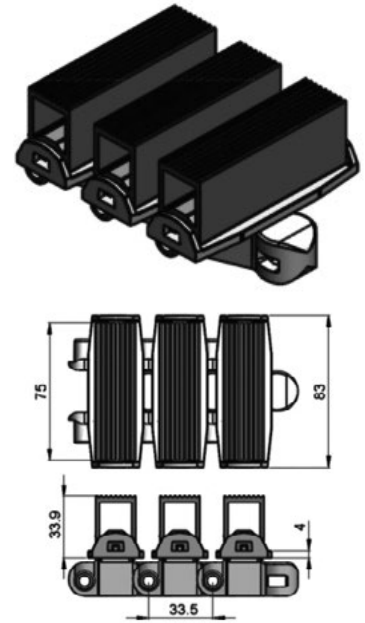

### Beam Example

Conveyor Beam **FMCB-3**

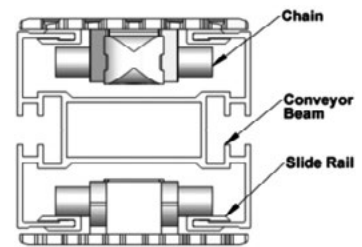
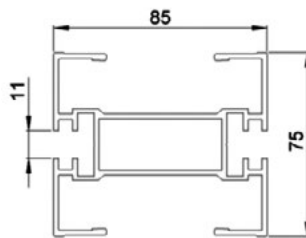

### Chain Connecting Module Example

Chain Connecting Module **FMCC-160**

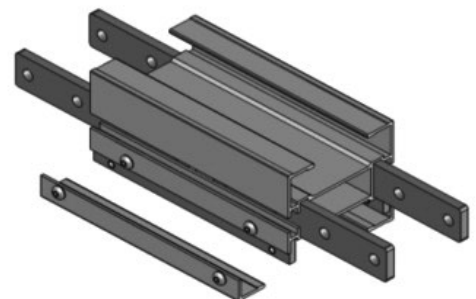
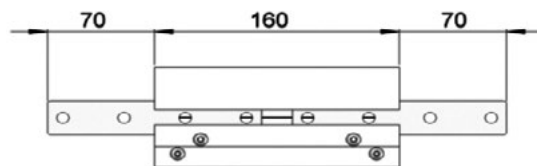

Chain connecting modules are required on all Wedge Conveyors.

## Bends Examples

FM Wheel Bend 90°

FMWB-90R160A

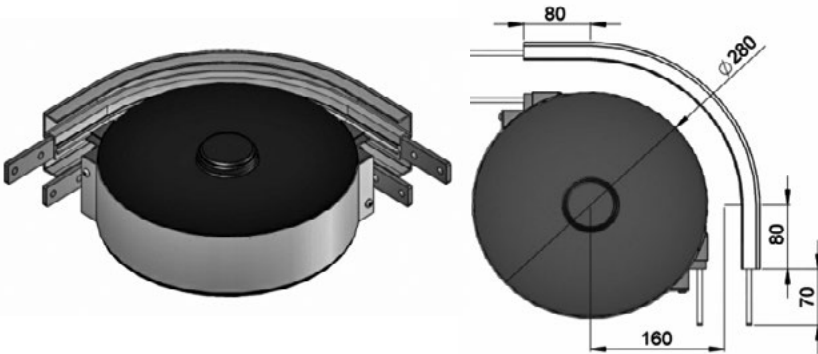

Wheel corners can be used for small products.

FM Horizontal Plain Bend 90°

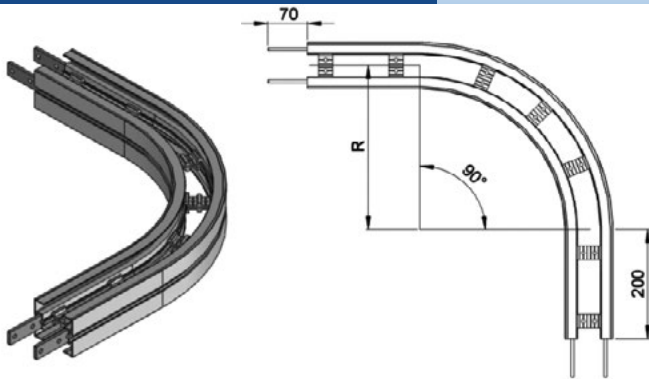

**Horizontal plain bend, 90° ± 1°**

- R = 300 ± 10mm      **FMHB-90R300**
- R = 500 ± 10mm      **FMHB-90R500**
- R = 700 ± 10mm      **FMHB-90R700**
- R = 1000 ± 10mm     **FMHB-90R1000**

Plain Bend corners are required for large products.

## Drive Tail Examples

FM Direct End Drive without Motor GP (LEFT)

FM Direct End Drive without Motor GP (RIGHT)

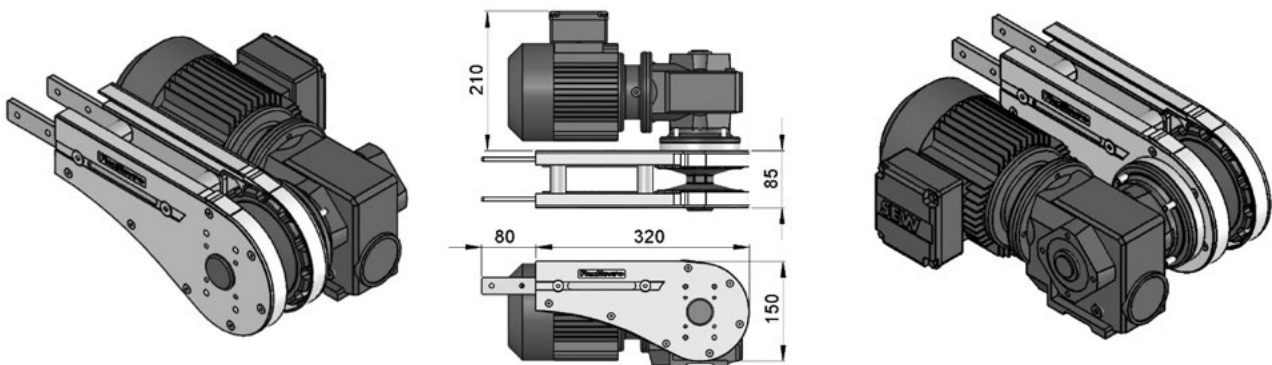

GP Drives Ends are required as the conveyor is on edge and no catenary take-up is possible.

## Idler End Examples

FM Idler End 85

FMIE-A85

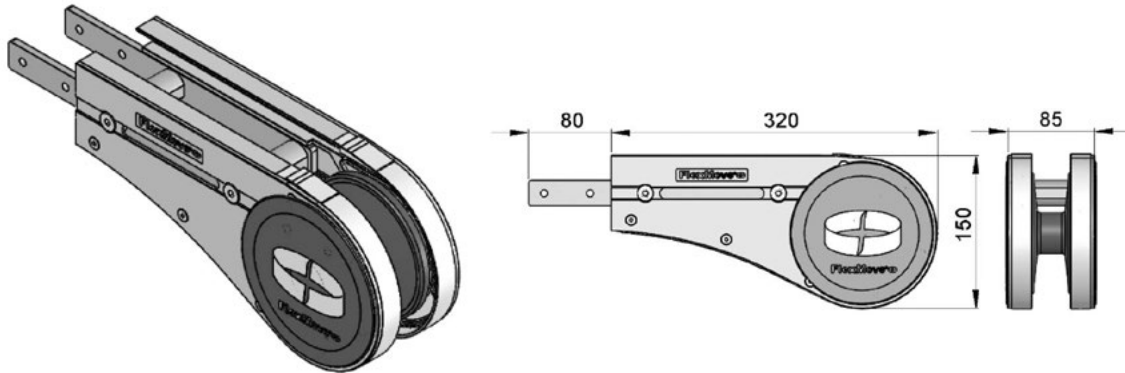

## Mechanical Adjustment Examples

FZWA-660A

Width Adjustment Actuator 660mm

FZWA-950A

Width Adjustment Actuator 950mm

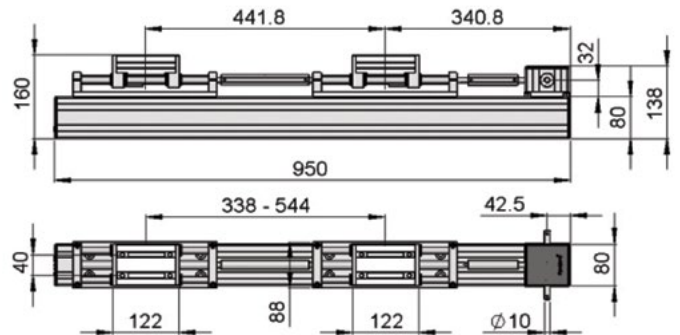
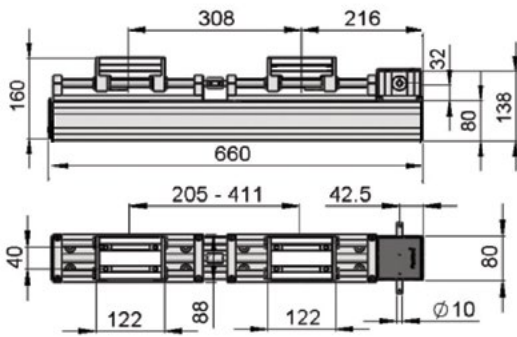

## Angle Gear Units Examples

FZGB-903

Angle Gear Unit-3 direction

FZGB-904

Angle Gear Unit - 4 direction

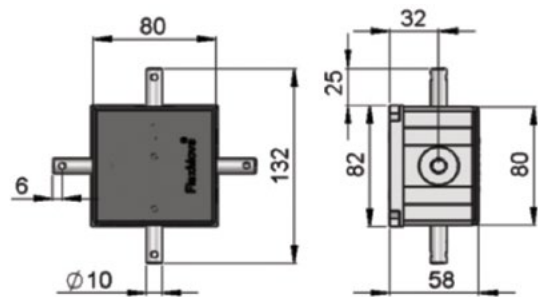
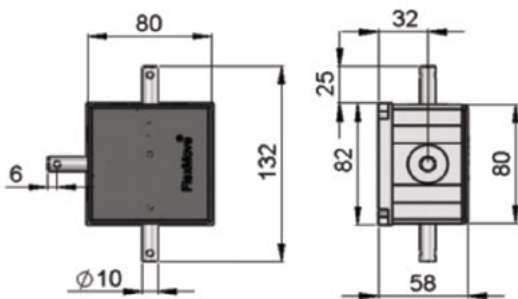



## Purchasing Wedge Conveyors

Dorner offers three solutions for purchasing a Wedge Conveyor.

- The first solution is to order all the necessary parts and components to build your FlexMove Conveyor on site. This will require the proper tools for cutting, bending and installing the conveyor. Consult our installation guide for FlexMove Conveyors for more details.
- The second solution is to have a complete conveyor provided through our FlexMove Solutions. With Flexmove Solutions you can have the conveyor built in our facility, tested, broken down into shippable sections and ship to the end site for installation.
- The third solution is to work with Dorner to have your FlexMove Conveyor assembled at the final site. The Conveyor will be purchased similar to option 1, but will be shipped as pre-cut and sized components. The Dorner installation team will then assemble and test the equipment at your location. Contact a Dorner representative for a quote on this service.

---

### About Dorner:

With over 50 years of experience, Dorner is an Industry Leader in the design, applications, manufacturing, and integration of conveyor systems. Focusing on solving industrial, packaging, and sanitary conveyor automation needs, Dorner offers a wide range of conveyor solutions, which are flexible, easy to select, easy to integrate, and easy to acquire through a world class delivery & support network. From our sales and support team to our D-Tools online conveyor configurator, we are eager to help you find the right solution for your product handling needs!

[www.dorner.com](http://www.dorner.com) | [info@dorner.com](mailto:info@dorner.com)



TRANSFORMING CONVEYOR AUTOMATION





**Industrial**



**Flexible Chain**



**Pallet Systems**



**Sanitary Stainless Steel**

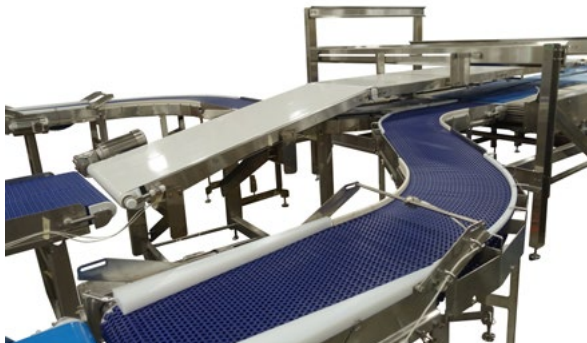

**Engineered Solutions Group**

Custom engineered solutions for almost any application.



**CAD Configurator Tool**

Industry leading tool! Configure your own custom conveyor in minutes.

# TRANSFORMING CONVEYOR AUTOMATION

## Contact Dorner

**United States**  
+1-262-367-7600

**Canada**  
+1-289-208-7306

**Mexico**  
+52.33.30037400

**Germany**  
+49 (0) 2461/93767-0

**France**  
+33 (0)1 84 73 24 27

**Malaysia**  
+604-626-2948



By Columbus McKinnon

**DORNERCONVEYORS.COM**



CONVEYANCE SOLUTIONS

© Dorner Mfg. Corp. 2024. All Rights Reserved.

851-906 0824