

CLAMPING MODULE

- Pneumatic clamping actuator, mounted on both sides of the conveyor, holds back and paces product
- Ability to pace products back to back
- Ideal for totes, boxes, bottles and square, round, and rectangular containers
- Product must be able to withstand some back pressure and squeezing force
- Requires photo sensors, pneumatic solenoid valves, wiring, and programming
- Rate depends on product size. Contact factory for details

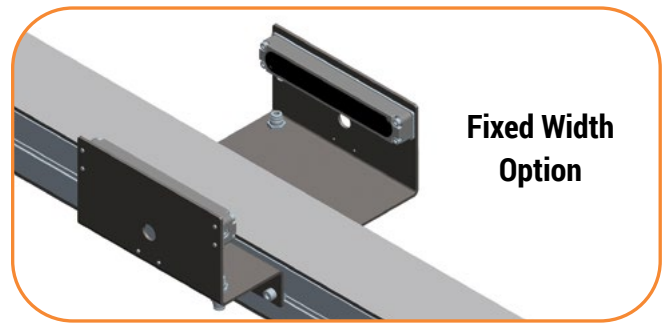

Fixed Width Option



Adjustable Width Option

FEATURES & SPECIFICATIONS

- Available on FlexMove Aluminum Conveyors, FS (65 mm), FM (85 mm), FC (105 mm), FL (150 mm), FU (180 mm), and FV (260 mm)
- Max. single product weight: 2.3 Kg (5 lbs)
- Max. product accumulation weight: 13.6 Kg (30 lbs)
- Specify product width at time of ordering
- Specify centerline of clamping actuator above conveyor chain at time of ordering
- Max. conveyor speed: 50 m/min (164 ft/min)
- Produces gap of approximately one product length
- Includes mounting for photo sensor with 18 mm barrel

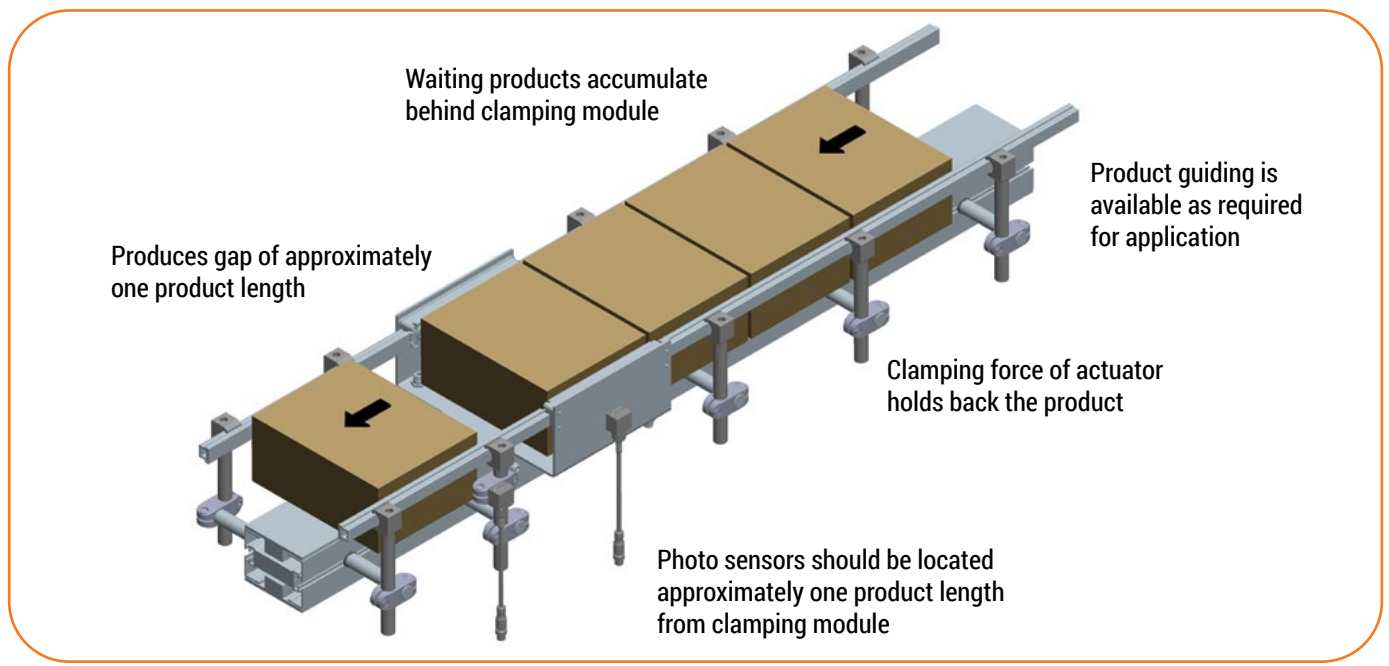

DIMENSIONS

Fixed Width Option

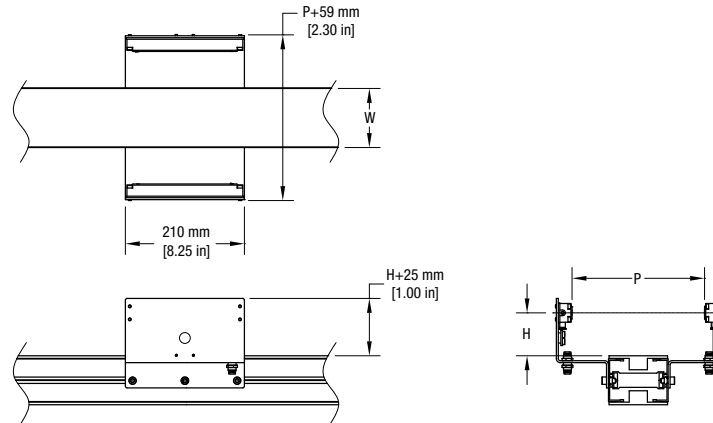

Adjustable Width Option

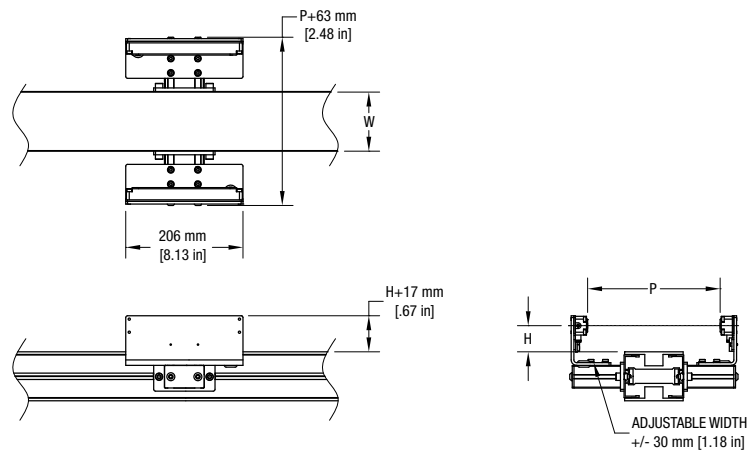

Specify at time of order:

W = conveyor width

P = product width

H = centerline of clamping actuator above conveyor chain

TRANSFORMING CONVEYOR AUTOMATION

Dorner – North & South America

Dorner Mfg. Corp.
USA
+1-262-367-7600

Dorner Conveyors Ltd.
Canada
+1-289-208-7306

Dorner Latin America,
S. de R.L. de C.V.
+52.33.30037400

DORNER[®]
By Columbus McKinnon

Dorner – Europe

Dorner GmbH–Germany +49 (0) 2461/93767-0
Dorner SARL–France +33 (0)1 84 73 24 27

Dorner – Asia

Dorner (M) Sdn. Bhd.
Malaysia
+604-626-2948

dornerconveyors.com

© Dorner Mfg. Corp. 2024.
All Rights Reserved.
851-929 0924