

ENGINEERING MANUAL

Superior V-Guided
Belt Tracking

24VDC iDrive v2
Technology

Fast & Simple to Use
Online Configurator

Affordable
Precision Conveyors



DCMove BELTED SERIES

Heavy Duty, Painted Steel Construction
Fabric Belt Conveyors

DORNER[®]
By Columbus McKinnon



End Drive

- Provides cost effective package handling, widths 254 mm (10 in) to 1219 mm (48 in) with 76 mm (3 in) diameter rollers



Nose Bar

- 32mm (1-1/4 in) bar option; ideal for accurate package transfer



Flush Side Frames

- All bearings and components located inside conveyor frame for flat sided tails that fit in tight spaces



iDRIVE

- The industry's most compact internal drive for 24/7 operation in conveyors as narrow as 254 mm (10 in) wide

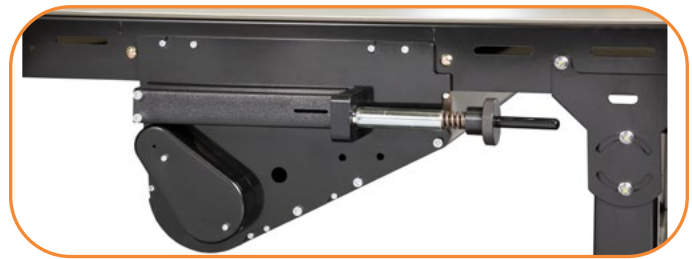

Center Drive

- Provides longer length of conveyor up to 30,000 mm (98 ft)



V-Guided Belt Tracking

- Superior V-guided belting eliminates the need for tracking adjustments

The Benefits of a Dorner DCMove Material Handling Conveyor

Low Maintenance

- Dorner's industry best V-guiding provides positive belt tracking, even under demanding side load applications
- Painted steel construction for most cost competitive package movement
- Precise rack and pinion belt tensioning
- Sealed for life bearings

Time Saving

- Dorner's online configurator engineers simple or complex conveyors to meet your needs in minutes
- The industry leading tool delivers a complete 3D CAD assembly model for instant validation of fit
- Dorner provides the industry's fastest deliveries

ACCESSORIES
PAGE 38

PROFILES AND GUIDING BELTED CONVEYOR
PAGE 16-17

BELTS
PAGE 18-20

STRAIGHT BELTED CONVEYOR
PAGE 6-15

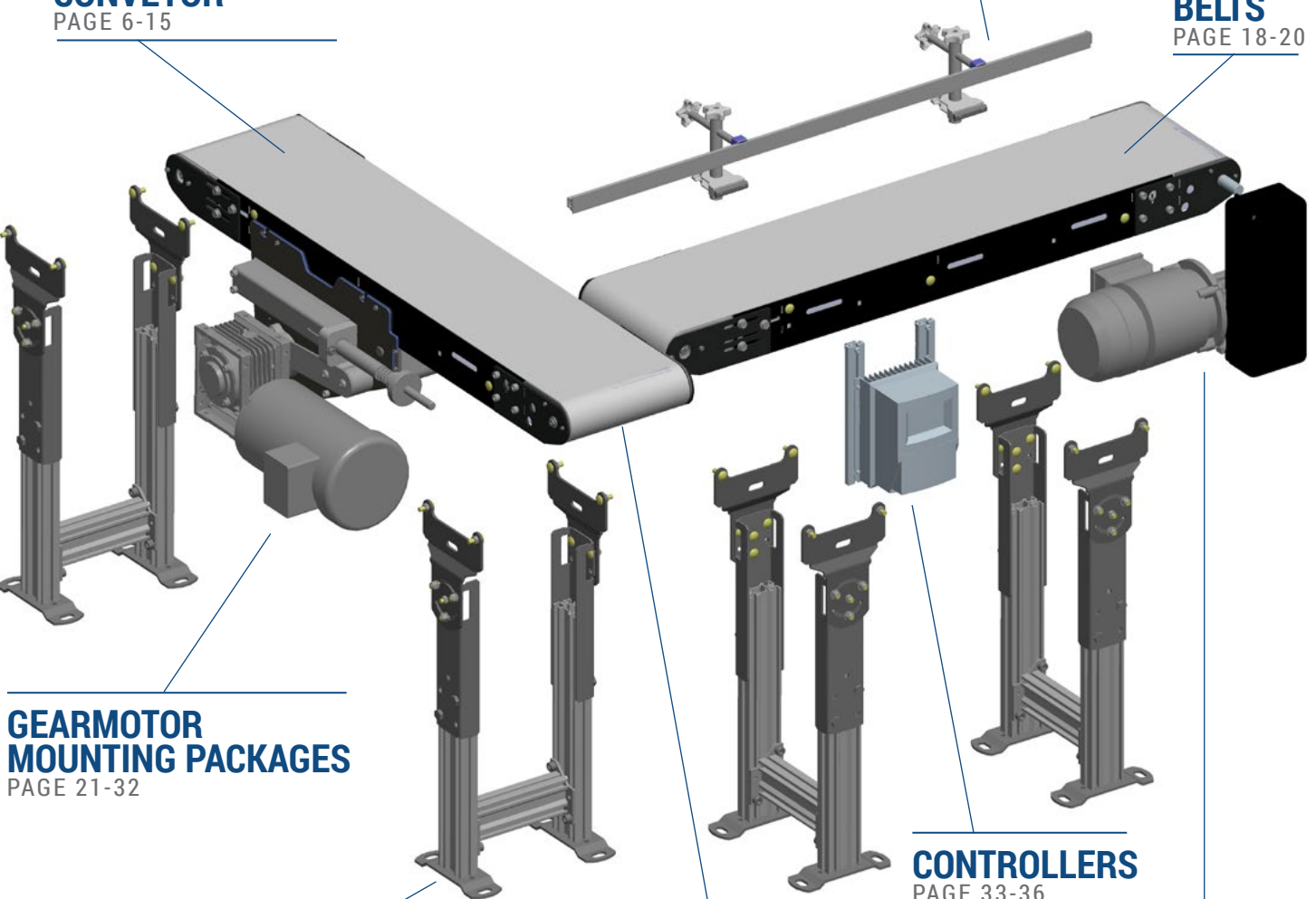

GEARMOTOR MOUNTING PACKAGES
PAGE 21-32

CONTROLLERS
PAGE 33-36

SUPPORT STANDS
PAGE 37

I-DRIVE OPTION
PAGE 10-13

GEARMOTORS
PAGE 21-24

 **TECHNICAL DATA & CALCULATIONS**
PAGE 39-49



**iDRIVE V2
CONTINUOUS DUTY
24VDC MOTORS**
MOST COMPACT CONVEYOR
DRIVE PACKAGE. INTERNAL
GEARMOTOR ALLOWS THE
CONVEYOR TO FIT IN TIGHT
SPACES

**BELTING CONFIGURATION
FLEXIBILITY**
ALLOWS CONVEYOR
CONFIGURATION TO MEET A
VARIETY OF APPLICATIONS

**BLACK POWDER PAINT
STEEL CONSTRUCTION**
PROVIDES DURABILITY &
RIGIDITY TO THE CONVEYOR
FRAME

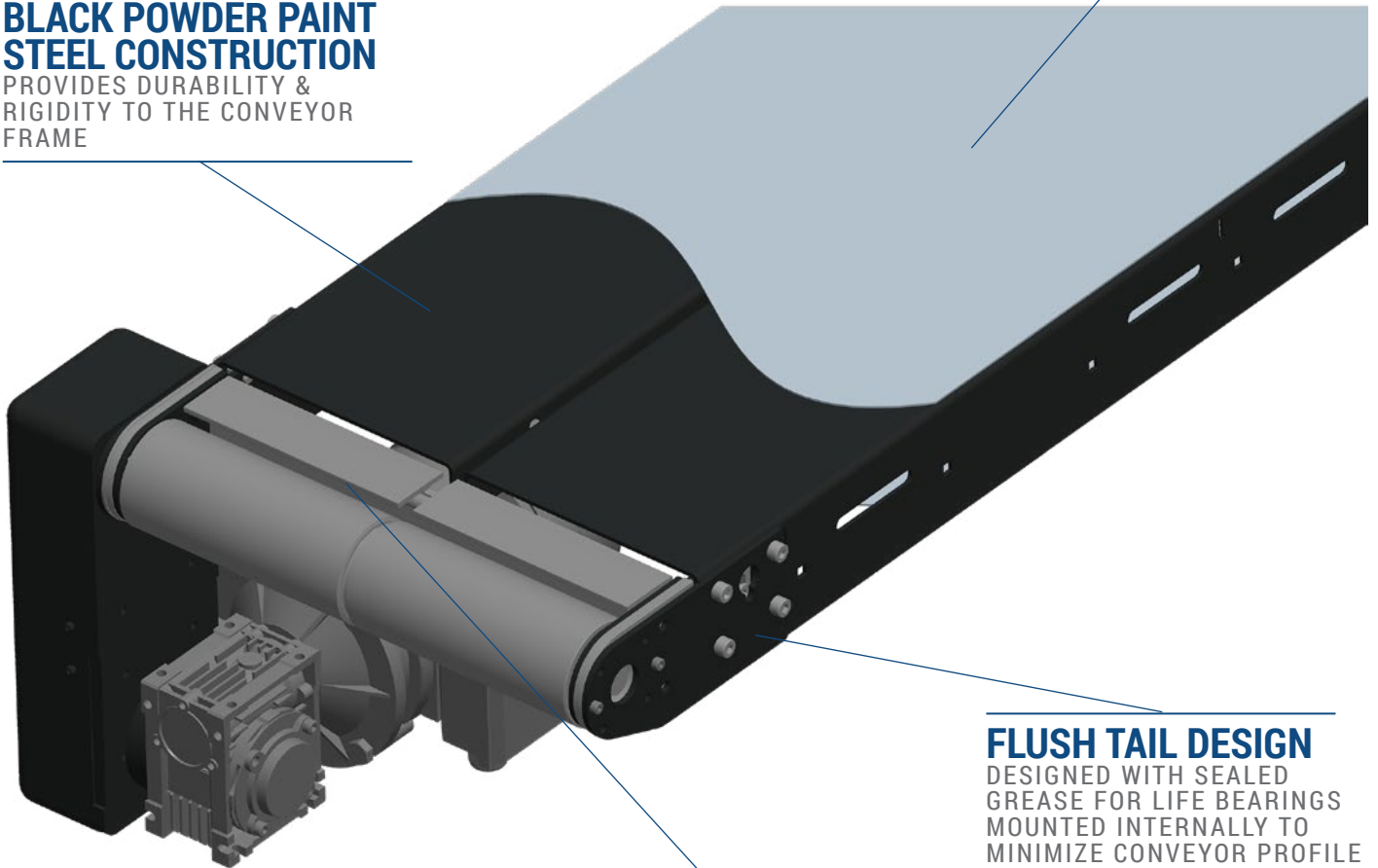

FLUSH TAIL DESIGN
DESIGNED WITH SEALED
GREASE FOR LIFE BEARINGS
MOUNTED INTERNALLY TO
MINIMIZE CONVEYOR PROFILE
AND ALLOW CONVEYOR TO
FIT IN TIGHT SPACES

**V-GROOVED ROLLER
& V-GUIDED BELTS**
PROVIDES MAINTENANCE-
FREE BELT TRACKING EVEN
ON DEMANDING SIDE
TRANSFER APPLICATIONS

eDRIVE®
LOW INERTIA MOTOR OPTION
WITH ALUMINUM BODY PROVIDES
LOW TEMPERATURE IN A SMALL
PACKAGE

**CENTER DRIVE
CONFIGURATION**
RELOCATES THE MOTOR
TO THE CENTER OF THE
CONVEYOR FREEING
UP BOTH ENDS OF
THE CONVEYOR, AND
ALLOWS FOR LONGER
LENGTHS





VARIETY OF PRODUCT GUIDING

ALLOWS CONVEYOR TO MEET AN ASSORTMENT OF PRODUCTS

RACK AND PINION BELT TENSIONING SYSTEM

STANDARD TENSIONING SYSTEM PROVIDES QUICK AND ACCURATE BELT TENSIONING

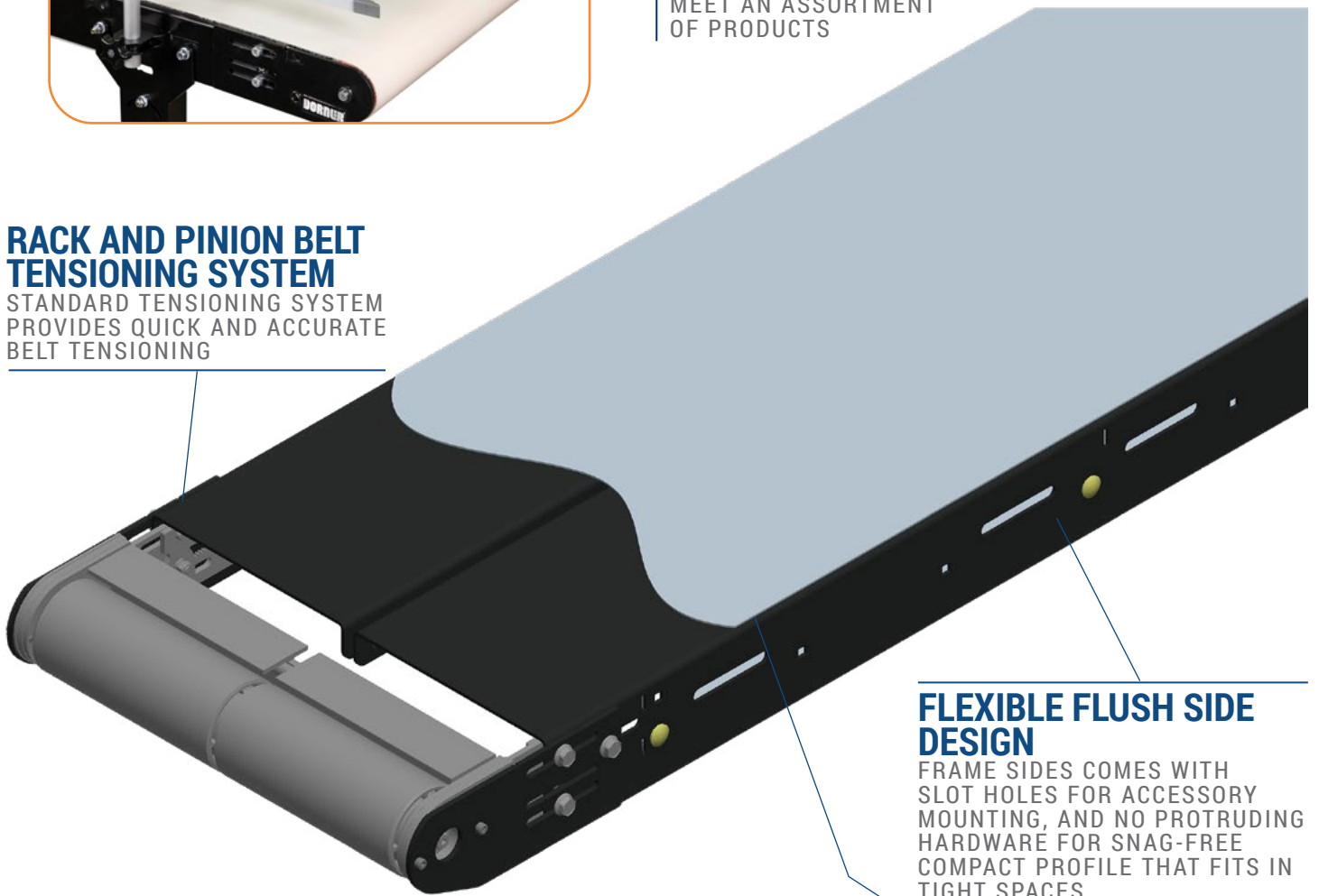

FLEXIBLE FLUSH SIDE DESIGN

FRAME SIDES COMES WITH SLOT HOLES FOR ACCESSORY MOUNTING, AND NO PROTRUDING HARDWARE FOR SNAG-FREE COMPACT PROFILE THAT FITS IN TIGHT SPACES

ACCURATE TIGHT-FITTING, NO GAP DESIGN

PROVIDES SNAG-FREE CONVEYOR, PRODUCTS WILL NOT FALL IN GAPS AND PROVIDES AN OPERATOR SAFE CONVEYOR



NOSEBAR TAIL OPTIONS

V-GUIDED, 32MM (1-1/4") NOSEBAR PROVIDES MEANS OF ACCURATELY HANDLING SMALL PACKAGES THROUGH TRANSFERS



Specifications

- Loads up to 181 kg (400 lbs)*
- Belt speeds up to 183 m/min (600 ft/min)
- Belt widths: 254 to 1,219 mm (10 to 48 in)
- Conveyor lengths: 960 to 12,000 mm (38 in to 40 ft)
- 33 mm (1.30 in) of belt take-up on conveyors
- 76 mm (3 in) diameter drive pulley turns approximately 246 mm (9.7 in) of belt per revolution
- V-groove bedplate with guided belt provides positive belt tracking, even under demanding side load applications
- Belt take-up indicator allows for quick reading of remaining belt life



STANDARD FEATURE:
Cam Belt Tracking

Accurate cam tracking for adjusting non V-Guided belts.



OPTIONAL: Auxiliary Shaft

Ideal for mounting external devices.



OPTIONAL: Nose Bar Tail

Includes sealed bearings, 32 mm (1.25 in) diameter rollers and is available at idler end for small part transfers.



STANDARD FEATURE:
Rack and Pinion

Allows the tail section to be easily slid back for quick belt removal.

DCMove Material Handling Flat Belt End Drive Conveyor

3	S	E	M	W	W	W	W	-	L	L	L	L	L	L	L	1	0	A	0	P	P	P	P	B	B
---	---	---	---	---	---	---	---	---	---	---	---	---	---	---	---	---	---	---	---	---	---	---	---	---	---

- Belt Type See Note
 - Profile (D side)
 - Profile (A side) 01 = Low Side, 02 = 25 mm (1 in) Painted Steel, 03 = 75 mm (3 in) Painted Steel, 06 = 150 mm (6 in) Painted Steel, 13 = Adjustable (33 mm flat), 14 = Tool-less Adjustable (33 mm flat), 43 = Adjustable (AL flat), 44 = Tool-less Adjustable (AL flat)
 - Idler Tail Type: 0 = Standard 76 mm (3 in) 2 = 1-1/4 Nose Bar
 - Drive Shaft Position: A, B, C or D
 - Drive Tail Type: 0 = Standard 76 mm (3 in), 1 = 76 mm (3 in) with aux shaft (opposite of drive shaft), 3 = 24V Integrated Drive
 - V-guide & Mounting Bracket Options: 1 = Non V-Guide belt. no return rollers, 2 = V-Guide belt, no return rollers brackets, 3 = Non V-Guide belt. with return rollers, 4 = V-Guide belt. with return rollers
 - Conveyor Length Reference: 00960 to 12000 in 5mm increments
 - Conveyor Width Reference: 254 mm to 1219 mm
 - Documentation Language: M = US, U = Europe English, D = German, F = French, S = Spanish
 - Prefix: 3S = DCMove Belted End Drives; E = End Drive Flat Belt

* Conveyor load capacity depends on conveyor size, incline, motor position, accumulated loads and other factors.

Order gearmotor mounting packages and gearmotors separately, see pages 21-32.
For support stands and accessories, see page 37.

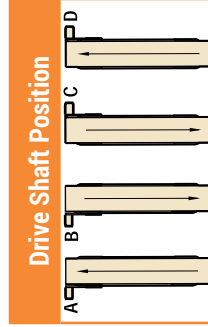
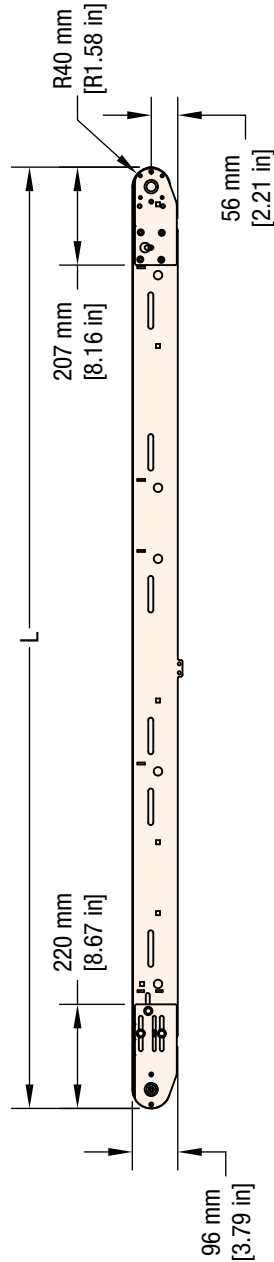
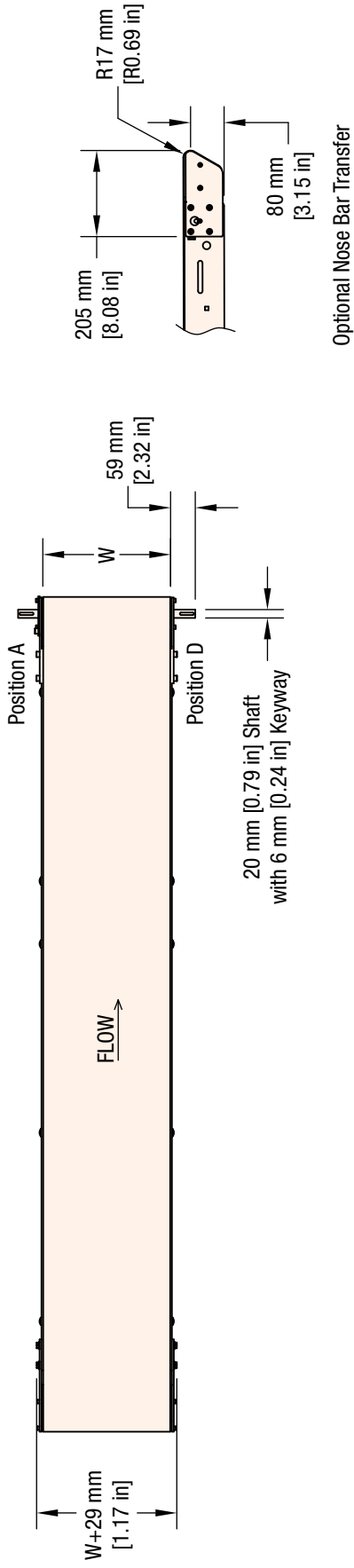

Since belts are being pulled, positions A & D are preferred. Pushing belts (B & C) reduce conveyor load capacity by approximately 66%.

W = Conveyor Belt Width Dim = mm (in)

Standard Sizes																				
Conveyor Width Reference	254	305	356	406	457	508	559	610	660	711	762	813	864	914	965	1016	1067	1118	1168	1219
Conveyor Belt Width (W)	254 mm (10 in)	305 mm (12 in)	356 mm (14 in)	406 mm (16 in)	457 mm (18 in)	508 mm (20 in)	559 mm (22 in)	610 mm (24 in)	660 mm (26 in)	711 mm (28 in)	762 mm (30 in)	813 mm (32 in)	864 mm (34 in)	914 mm (36 in)	965 mm (38 in)	1016 mm (40 in)	1067 mm (42 in)	1118 mm (44 in)	1168 mm (46 in)	1219 mm (48 in)
Conveyor Length Reference	00960										00005 Increments up to...									
Conveyor Length (L)	960 mm (3.1 ft)										5 mm (0.19 in) Increments up to... 12,000 mm (39.3 ft)									

NOTE: Conveyor longer than 2,985 mm (10 ft) will be constructed using a multiple piece frame. Consult factory for locations.

NOTE: Conveyors wider than 1016 mm (40 in) require v-guide belt tracking.



Specifications

- Loads up to 455 kg (1,000 lbs)*
- Belt speeds up to 183 m/min (600 ft/min)
- Belt widths: 254 to 1,219 mm (10 to 48 in)
- Conveyor lengths: 1,510 to 30,000 mm (60 in to 99 ft)
- 406 mm (16 in) of belt take-up
- 152 mm (6 in) diameter drive pulley turns approximately 479 mm (18.8 in) of belt per revolution
- Center drive module frees up both ends of conveyor for operator and machine interface
- The center drive module can be easily repositioned along the length of the conveyor, in increments of 450mm depending on conveyor length . Consult factory for exact location



STANDARD FEATURE: Cam Belt Tracking

Accurate cam tracking for adjusting non V-Guided belts.

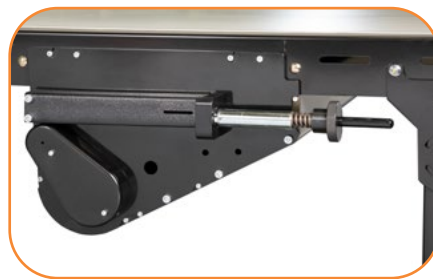

OPTIONAL: Spring Belt Take-up

Provides automatic belt take-up without the need for shop air.



OPTIONAL: Nose Bar Tail

Includes sealed bearings, 32 mm (1.25 in) diameter rollers and is available at both ends for small part transfers.

DCMove Material Handling Flat Belt Center Drive Conveyor

3	S	D	M	W	W	W	W	-	L	L	L	L	L	L	1	M	0	0	A	P	P	P	P	B	B
																							- Belt Type See Note		
																							- Profile (D side)		
																							- Profile (A side) 01 = Low Side, 02 = 25 mm (1 in) Painted Steel, 03 = 75 mm (3 in) Painted Steel, 6 = 150 mm (6 in) Painted Steel, 13 = Adjustable (33 mm flat), 14 = Tool-less Adjustable (33 mm flat)		
																							- Drive Shaft Position: A or D		
																							- Infeed Tail Type: 0 = Standard 76 mm (3 in), 2 = 1-1/4 Nose Bar		
																							- Exit Tail Type: 0 = Standard 76 mm (3 in), 2 = 1-1/4 Nose Bar		
																							- Center Drive Module: M = Manual spring, Y = SEW shaft / manual		
																							- V-guide & Mounting Bracket Options:		
																							1 = Non V-Guide belt. no return rollers, 2 = V-Guide belt, no return rollers brackets,		
																							3 = Non V-Guide belt. with return rollers, 4 = V-Guide belt. with return rollers		
																							- Conveyor Length Reference: 01510 to 30000 in 5mm increments		
																							- Conveyor Width Reference: 254 mm to 1219 mm		
																							- Documentation Language: M = US, U = Europe English, D = German, F = French, S = Spanish		
																							- Prefix: 3S = DCMove Belted Center Drives; D = Center drive Flat Belt		

* Conveyor load capacity depends on conveyor size, incline, motor position, accumulated loads and other factors.

Order gearmotor mounting packages and gearmotors separately, see pages 21-32.
For support stands and accessories, see page 37.

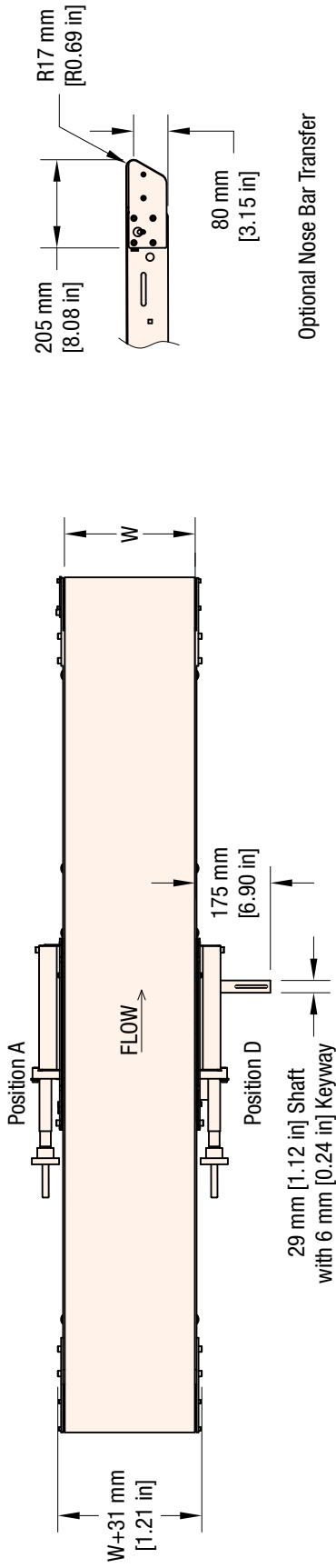

Optional Nose Bar Transfer

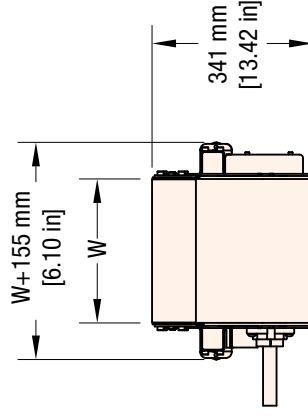

Drive Shaft Position

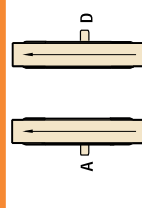

Reversing Belt Direction reduces conveyor load capacity to 66%.

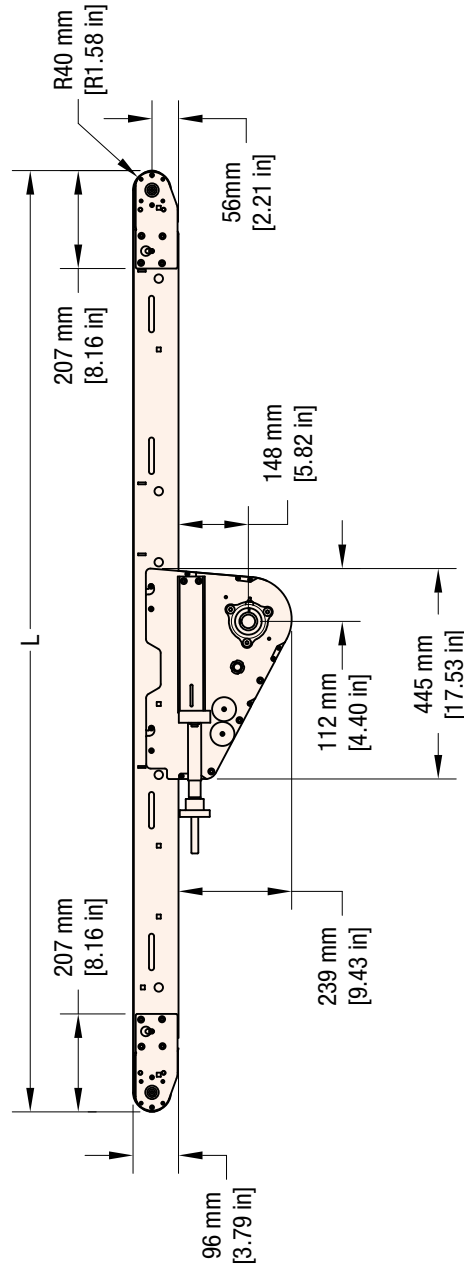

W = Conveyor Belt Width Dim = mm (in)

Standard Sizes

Conveyor Width Reference	254	305	356	406	457	508	559	610	660	711	762	813	864	914	965	1016	1067	1118	1168	1219
Conveyor Belt Width (W)	254 mm (10 in)	305 mm (12 in)	356 mm (14 in)	406 mm (16 in)	457 mm (18 in)	508 mm (20 in)	559 mm (22 in)	610 mm (24 in)	660 mm (26 in)	711 mm (28 in)	762 mm (30 in)	813 mm (32 in)	864 mm (34 in)	914 mm (36 in)	965 mm (38 in)	1016 mm (40 in)	1067 mm (42 in)	1118 mm (44 in)	1168 mm (46 in)	1219 mm (48 in)
Conveyor Length Reference	01210																			
Conveyor Length (L)	1,210 mm (4.0 ft)																			
Conveyor Length Reference	00005 Increments up to...																			
Conveyor Length (L)	5 mm (0.19 in) Increments up to...																			
Conveyor Length Reference	30000																			
Conveyor Length (L)	30,000 mm (98.4 ft)																			

NOTE: Conveyor longer than 2,985 mm (10 ft) will be constructed using a multiple piece frame. Consult factory for locations.

NOTE: Conveyors wider than 1016 mm (40 in) require v-guide belt tracking.



Specifications

- Belt widths: 254 to 914 mm (10 to 36 in)
- Conveyor lengths: 1,010 to 3,022 mm (40 in to 10 ft)
- Conveyor load capacity (non-accumulated, distributed load):
 - Single 24VDC brushless motor; 5 gear ratios to select from
 - from 1 m/min (3.3 ft/min) to 37.9 m/min (124 ft/min)
 - up to load of 68 Kg (150 lbs)
 - Dual 24VDC brushless motors; 7 gear ratios to select from
 - from 0.8 m/min (2.6 ft/min) to 45.8 m/min (150 ft/min)
 - up to load of 80 Kg (176 lbs)
- Indexing capable: Up to 30 indexes per minute
- Duty cycle: continuous rated
- Built-In / fixed acceleration and deceleration
- iDrive v2 control models:
 - Integrated forward/ off / reverse switch, variable toggle switch, and optional 115V 1 Ph input power supply
 - User controlled direction and speed via remote location, and optional 115V 1 Ph input power supply
 - Controller only to be integrated in central panel, motor leads can be purchased separately. Maximum motor lead distance can not exceed 3m (9.8 ft)
- V-guided belts for maintenance free belt tracking
- Maintenance free sealed bearings
- Grease filled, sealed for life gear boxes
- Maintenance free brushless DC Motor

OPTIONAL: Dual iDrive v2

Provides added capacity with synchronized motors, driven by one controller.

DCMove Material Handling Flat Belt iDRIVE Conveyor

3 S E M W W W W - L L L L L 1 0 A 0 P P P P B B - F T P M X

See Chart

M: A = Local keypad; direction and speed switches included, B = Remote location; direction and speed controlled remotely
 C = Controller drive only

P: N = No power supply, P = includes 115VAC to 24VDC power supply (only available for keypad and remote location options)

T: 1 = Single iDrivev2 motor, 2 = Dual iDrive v2 motor

F = Integrated Motor/Drive to Frame

Belt Type See Note

Profile (D side)

Profile (A side) 01 = Low Side, 02 = 25 mm (1 in) Painted Steel, 03 = 75 mm (3 in) Painted Steel, 6 = 150 mm (6 in) Painted Steel, 13 = Adjustable (33 mm flat), 14 = Tool-less Adjustable (33 mm flat)

Idle Tail Type: 0 = Standard 76 mm (3 in), 2 = 1-1/4 Nose Bar, 3 = 24V Integrated Drive

Drive Shaft Position: A, B, C or D

Drive Tail Type: 3 = 24V Integrated Drive

V-guide & Mounting Bracket Options: 1 = Non V-Guide belt. no return rollers, 2 = V-Guide belt, no return rollers brackets, 3 = Non V-Guide belt. with return rollers, 4 = V-Guide belt. with return rollers

Conveyor Length Reference: 01010 to 03022 in 5mm increments

Conveyor Width Reference: 254 mm to 914 mm

Documentation Language: M = US, U = Europe English, D = German, F = French, S = Spanish

Prefix: 3S = DCMove Belted End Drives; E = End Drive Flat Belt

Chart for X

Single Motor

G = 1 to 10.4 M/min (3.3 to 34 ft/min)

F = 1.5 to 15.4 M/min (4.9 to 51 ft/min)

E = 2.1 to 21.1 M/min (6.9 to 69 ft/min)

D = 2.6 to 25.7 M/min (8.5 to 84 ft/min)

C = 3.8 to 37.9 M/min (12.5 to 124 ft/min)

Dual Motor

P = 0.8 to 7.5 M/min (2.6 to 25 ft/min)

N = 1.1 to 11.2 M/min (3.6 to 37 ft/min)

M = 1.5 to 15.3 M/min (4.9 to 50 ft/min)

L = 1.9 to 18.6 M/min (6.2 to 61 ft/min)

K = 2.8 to 27.5 M/min (9.2 to 90 ft/min)

J = 3.4 to 33.5 M/min (11.2 to 110 ft/min)

H = 4.6 to 45.8 M/min (15.1 to 150 ft/min)

For support stands and accessories, see pages 37-38.

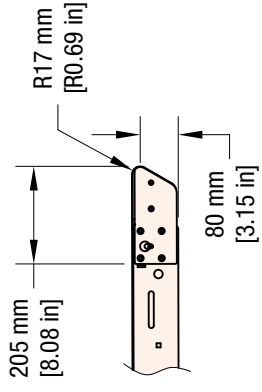

Optional Nose Bar Transfer

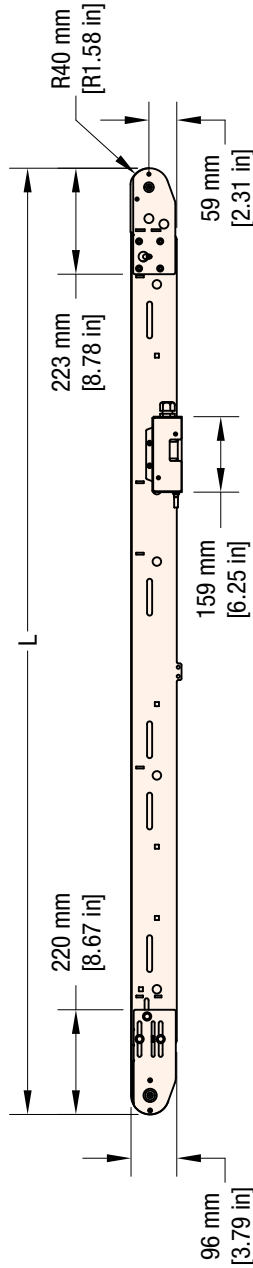
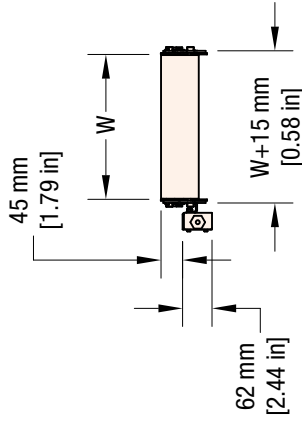
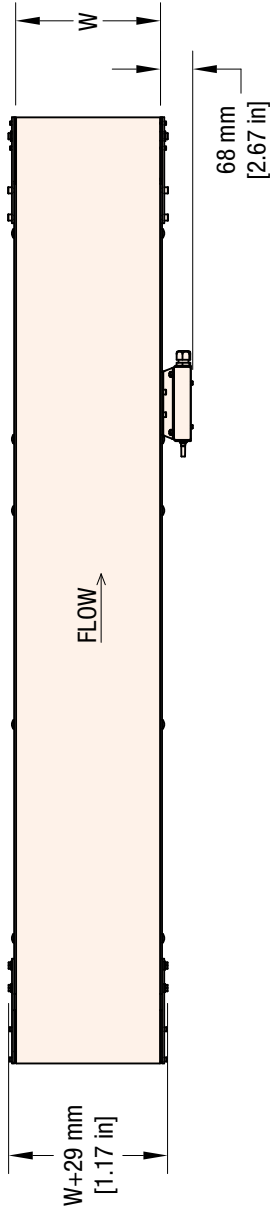

Controls shown in position "A"
W = Conveyor Belt Width Dim = mm (in)

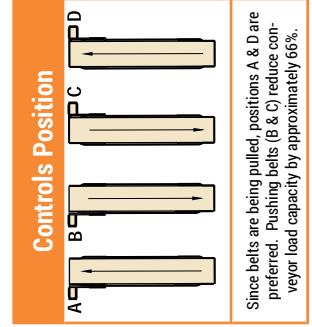

Standard Sizes														
Conveyor Width Reference	10	12	14	16	18	20	22	24	26	28	30	32	34	36
Conveyor Belt Width (W)	254 mm (10 in)	305 mm (12 in)	356 mm (14 in)	406 mm (16 in)	457 mm (18 in)	508 mm (20 in)	559 mm (22 in)	610 mm (24 in)	660 mm (26 in)	711 mm (28 in)	762 mm (30 in)	813 mm (32 in)	864 mm (34 in)	914 mm (36 in)
Conveyor Length Reference	01210													
Conveyor Length (L)	1,210 mm (4.0 ft)													
	00005 Increments up to ...													
	5 mm (0.19 in) Increments up to ...													
	03022													
	3,022 mm (9.9 ft)													

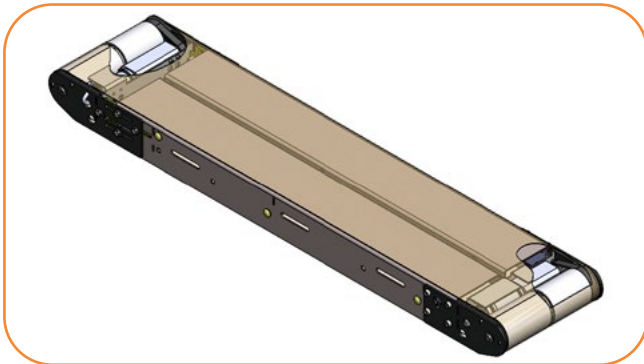

Specifications

- Belt widths: 254 to 914 mm (10 to 36 in)
- Conveyor lengths: 1,010 to 3,022 mm (40 in to 10 ft)
- Conveyor load capacity (non-accumulated, distributed load):
 - Single 24VDC brushless motor; 5 gear ratios to select from
 - from 1 m/min (3.3 ft/min) to 37.9 m/min (124 ft/min)
 - up to load of 68 Kg (150 lbs)
 - Dual 24VDC brushless motors; 7 gear ratios to select from
 - from 0.8 m/min (2.6 ft/min) to 45.8 m/min (150 ft/min)
 - up to load of 80 Kg (176 lbs)
- Indexing capable: Up to 30 indexes per minute
- Duty cycle: continuous rated
- Built-In / fixed acceleration and deceleration
- iDrive v2 control models:
 - Integrated forward/ off / reverse switch, variable toggle switch, and optional 115V 1 Ph input power supply
 - User controlled direction and speed via remote location, and optional 115V 1 Ph input power supply
 - Controller only to be integrated in central panel, motor leads can be purchased separately. Maximum motor lead distance can not exceed 3m (9.8 ft)
- V-guided belts for maintenance free belt tracking
- Maintenance free sealed bearings
- Grease filled, sealed for life gear boxes
- Maintenance free brushless DC Motor

OPTIONAL: Dual iDrive v2

Provides added capacity with synchronized motors, driven by one controller.

DCMove Material Handling Cleated Belt iDRIVE Conveyor

3 S C M W W W W - L L L L L 1 0 A 0 P B S S S S - F T P M X

See Chart

M: A = Local keypad; direction and speed switches included, B = Remote location; direction and speed controlled remotely
 C = Controller drive only

P: N = No power supply, P = includes 115VAC to 24VDC power supply (only available for keypad and remote location options)

T: 1 = Single iDrive2 motor, 2 = Dual iDrive v2 motor

F = Integrated Motor/Drive to Frame

Cleat Spacing: SSSS mm

Belt/Cleat See Note

Profile (A & D side): 1 = Low Side, 2 = 25 mm (1 in) Painted Steel, 3 = 75 mm (3 in) Painted Steel, 6 = 150 mm (6 in) Painted Steel

Idle Tail Type: 0 = Standard 76 mm (3 in), 3 = 24V Integrated Drive

Drive Shaft Position: A, B, C or D

Drive Tail Type: 3 = 24V Integrated Drive

V-guide & Mounting Bracket Options: 1 = Non V-Guide belt. no return rollers, 2 = V-Guide belt, no return rollers brackets, 3 = Non V-Guide belt. with return rollers, 4 = V-Guide belt. with return rollers

Conveyor Length Reference: 01010 to 03022 in 5mm increments

Conveyor Width Reference: 254 mm to 914 mm

Documentation Language: M = US, U = Europe English, D = German, F = French, S = Spanish

Prefix: 3S = DCMove Belted End Drives; C = End Drive Cleated Belt

Chart for X	
Single Motor	
G	= 1 to 10.4 M/min (3.3 to 34 ft/min)
F	= 1.5 to 15.4 M/min (4.9 to 51 ft/min)
E	= 2.1 to 21.1 M/min (6.9 to 69 ft/min)
D	= 2.6 to 25.7 M/min (8.5 to 84 ft/min)
C	= 3.8 to 37.9 M/min (12.5 to 124 ft/min)
Dual Motor	
P	= 0.8 to 7.5 M/min (2.6 to 25 ft/min)
N	= 1.1 to 11.2 M/min (3.6 to 37 ft/min)
M	= 1.5 to 15.3 M/min (4.9 to 50 ft/min)
L	= 1.9 to 18.6 M/min (6.2 to 61 ft/min)
K	= 2.8 to 27.5 M/min (9.2 to 90 ft/min)
J	= 3.4 to 33.5 M/min (11.2 to 110 ft/min)
H	= 4.6 to 45.8 M/min (15.1 to 150 ft/min)

For support stands and accessories, see pages 37-38.

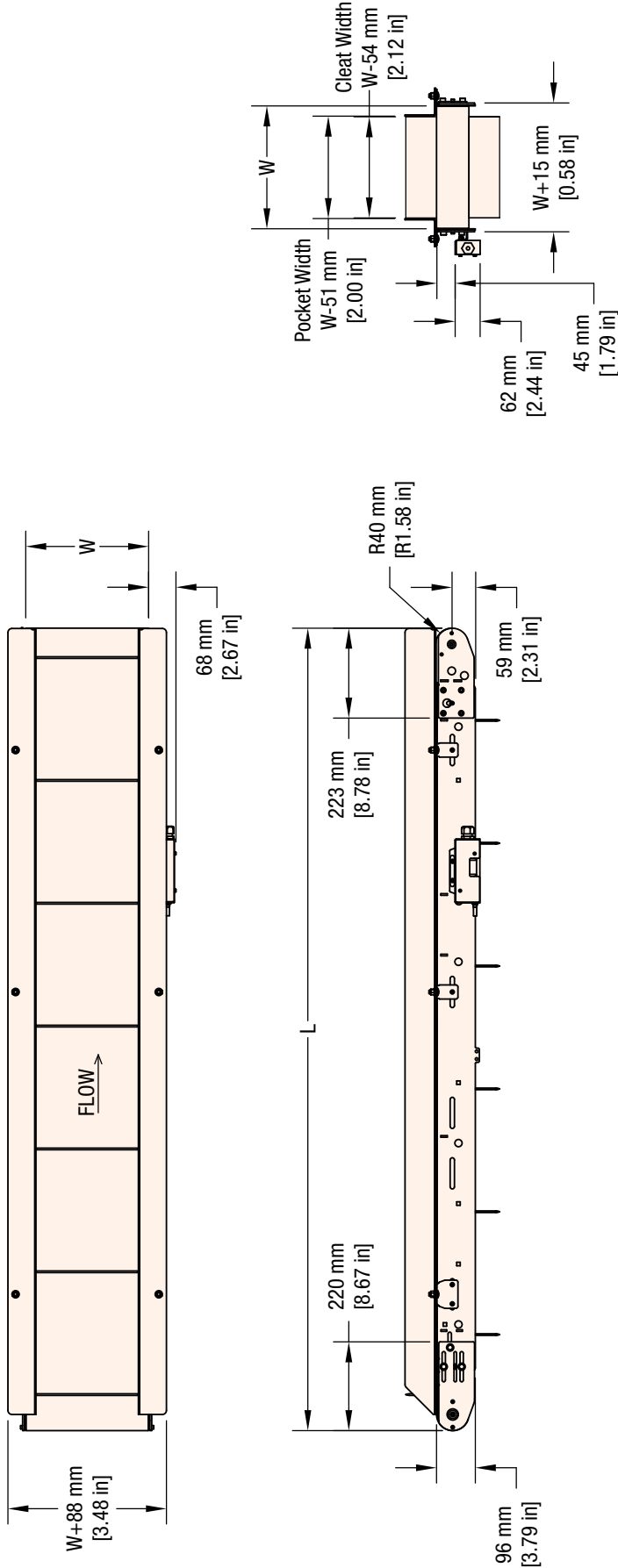

Controls shown in position "A"
 W = Conveyor Belt Width Dim = mm (in)

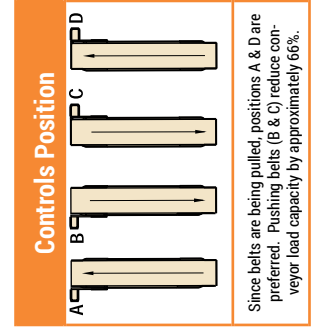

Since belts are being pulled, positions A & D are preferred. Pushing belts (B & C) reduce conveyor load capacity by approximately 66%.

Standard Sizes														
Conveyor Width Reference	254	305	356	406	457	508	559	610	660	711	762	813	864	914
Conveyor Belt Width (W)	254 mm (10 in)	305 mm (12 in)	356 mm (14 in)	406 mm (16 in)	457 mm (18 in)	508 mm (20 in)	559 mm (22 in)	610 mm (24 in)	660 mm (26 in)	711 mm (28 in)	762 mm (30 in)	813 mm (32 in)	864 mm (34 in)	914 mm (36 in)
Conveyor Length Reference	01210													
Conveyor Length (L)	1,210 mm (4.0 ft)													
	00005 Increments up to ...													
	5 mm (0.19 in) Increments up to ...													
	03022													
	3,022 mm (9.9 ft)													



Specifications

- Loads up to 181 kg (400 lbs)*
- Belt speeds up to 183 m/min (600 ft/min)
- Belt widths: 254 to 1,219 mm (10 to 48 in)
- Conveyor lengths: 960 to 12,000 mm (38 in to 40 ft)
- Cleats available from 6 to 150 mm (0.24 to 5.9 in) high
- 51 mm (2 in) minimum cleat spacing
- 33 mm (1.30 in) of belt take-up on conveyors
- 76 mm (3 in) diameter drive pulley turns approximately 246 mm (9.7 in) of belt per revolution



OPTIONAL: Auxiliary Shaft
Ideal for mounting external devices.



STANDARD FEATURE: Rack and Pinion
Allows the tail section to be easily slid back for quick belt removal.

DCMove Material Handling Cleated Belt End Drive Conveyor																											
3	S	C	M	W	W	W	W	-	L	L	L	L	L	1	0	A	0	P	B	S	S	S	S				
												- Cleat Spacing: SSSS mm															
												- Belt Type See Note															
												- Profile (A & D side) 1 = Low Side, 2 = 25 mm (1 in) Painted Steel, 3 = 75 mm (3 in) Painted Steel, 6 = 150 mm (6 in) Painted Steel															
												- Idler Tail Type: 0 = Standard 76 mm (3 in)															
												- Drive Shaft Position: A, B, C or D															
												- Drive Tail Type: 0 = Standard 76 mm (3 in), 1 = 76 mm (3 in) with aux shaft (opposite of drive shaft)															
												- V-guide & Mounting Bracket Options:															
												1 = Non V-Guide belt. no return rollers, 2 = V-Guide belt, no return rollers brackets,															
												3 = Non V-Guide belt. with return rollers, 4 = V-Guide belt. with return rollers															
												- Conveyor Length Reference: 00960 to 12000 in 5mm increments															
												- Conveyor Width Reference: 254 mm to 1219 mm															
												- Documentation Language: M = US, U = Europe English, D = German, F = French, S = Spanish															
												- Prefix: 3S = DCMove Belted End Drives; C = End Drive Cleated Belt															

* Conveyor load capacity depends on conveyor size, incline, motor position, accumulated loads and other factors.

Order gearmotor mounting packages and gearmotors separately, see pages 21-32.
For support stands and accessories, see page 37.

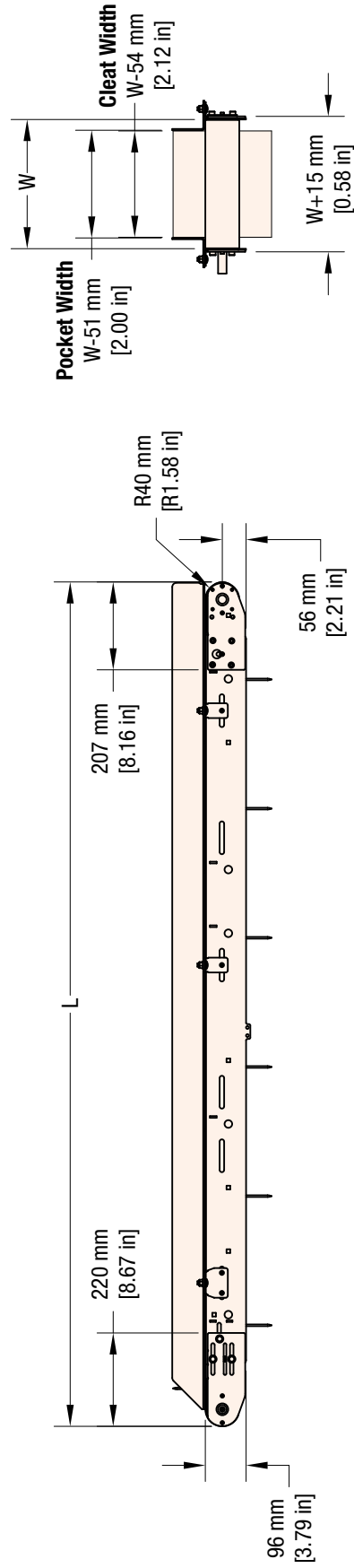
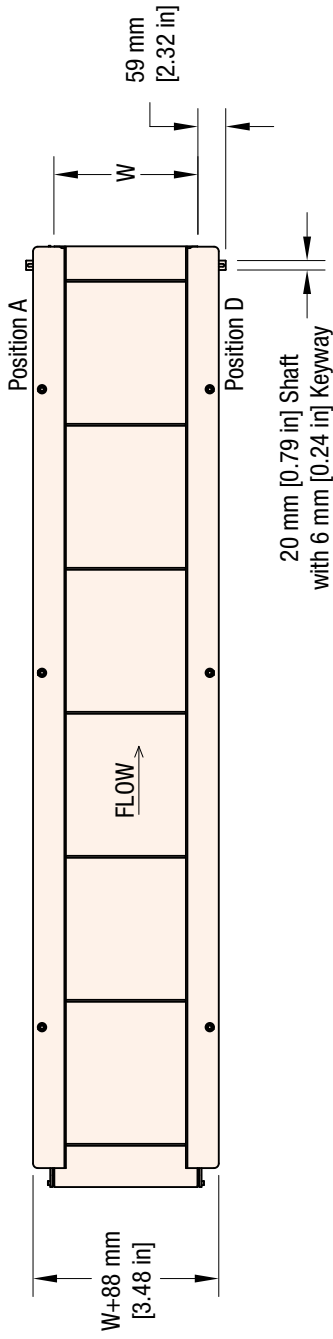

Drive Shaft Position

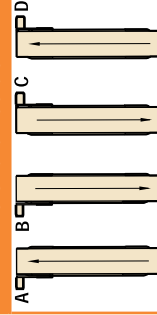

Since belts are being pulled, positions A & D are preferred. Pushing belts (B & C) reduce conveyor load capacity by approximately 66%.

W = Conveyor Belt Width

Standard Sizes

Conveyor Width Reference	254	305	356	406	457	508	559	610	660	711	762	813	864	914	965 mm (38 in)	1016 mm (40 in)	1067 mm (42 in)	1118 mm (44 in)	1168 mm (46 in)	1219 mm (48 in)
Conveyor Belt Width (W)	254 mm (10 in)	305 mm (12 in)	356 mm (14 in)	406 mm (16 in)	457 mm (18 in)	508 mm (20 in)	559 mm (22 in)	610 mm (24 in)	660 mm (26 in)	711 mm (28 in)	762 mm (30 in)	813 mm (32 in)	864 mm (34 in)	914 mm (36 in)	965 mm (38 in)	1016 mm (40 in)	1067 mm (42 in)	1118 mm (44 in)	1168 mm (46 in)	1219 mm (48 in)
Conveyor Length Reference	00960																			
Conveyor Length (L)	960 mm (3.1 ft)																			
	00005 Increments up to...										12000									
	5 mm (0.19 in) Increments up to...																			
	12,000 mm (39.3 ft)																			

NOTE: Conveyor longer than 3,658 mm (12 ft) will be constructed using a multiple piece frame. Consult factory for locations.

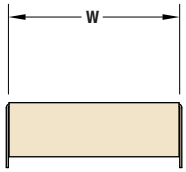

Profile 01
Low Side

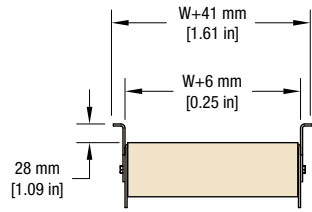

Profile 02
25 mm (1.00 in) High Side

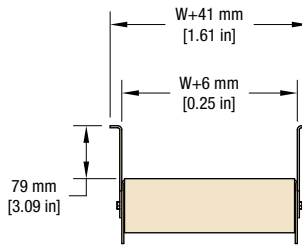

Profile 03
75 mm (3.00 in) High Side

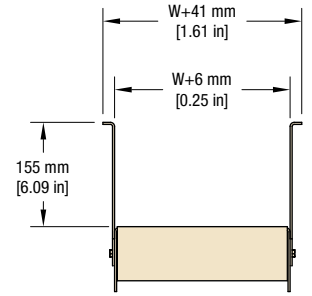

Profile 06
150 mm (6.00 in) High Side

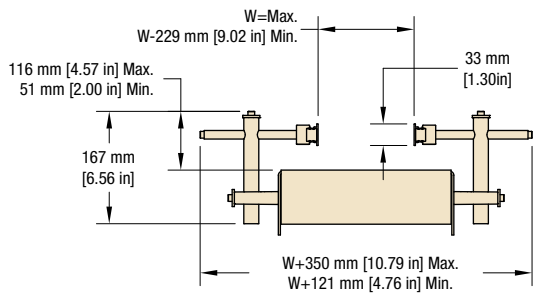

Profile 13
Adjustable Guiding 33 mm (1.30 in) HDPE Face

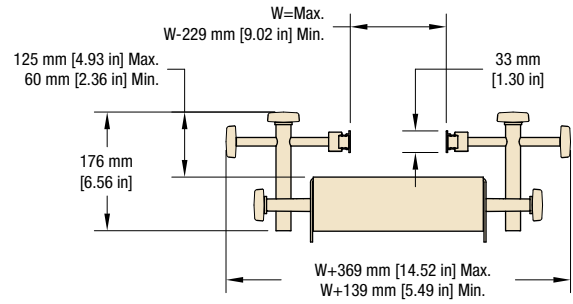

Profile 14
Tool-less Adjustable Guiding 33 mm (1.30 in) HDPE Face

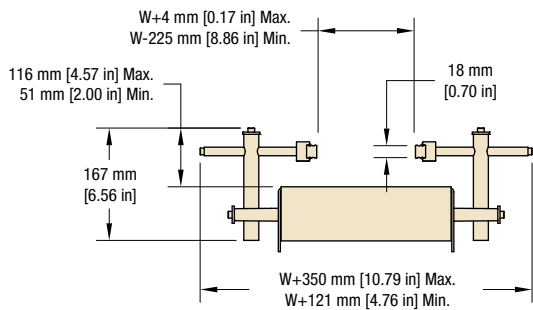

Profile 43
Adjustable Guiding Aluminum Face

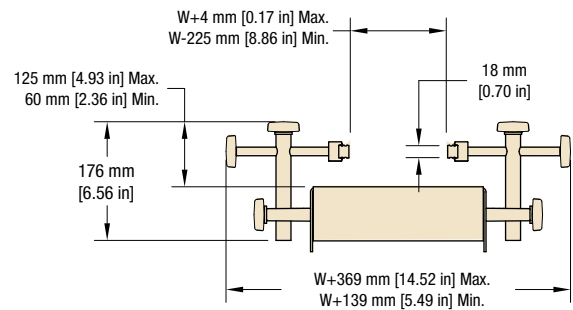

Profile 44
Tool-less Adjustable Guiding Aluminum Face

Dimensions = mm (in)



02 Guide
25 mm (1 in) High Side



14 & 06 Guide
Combination of Tool-less Adjustable Guiding and
150 mm (6.00 in) High Side

Due to the wide variety of drive set ups and applications, point of installation guarding is the responsibility of the end user.

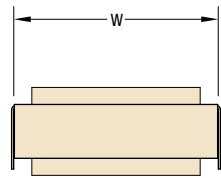

Cleat Profile 0
Low Side

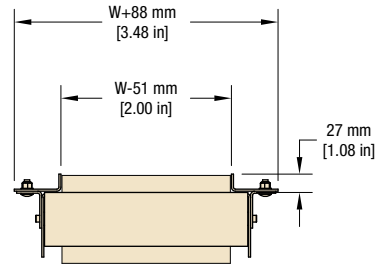

Cleat Profile 1
25 mm [1.00 in] High Side

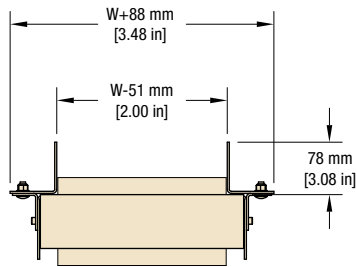

Cleat Profile 3
75 mm [3.00 in] High Side

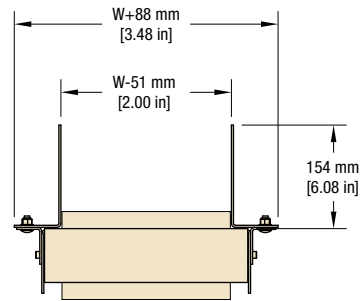

Cleat Profile 6
105 mm [6.00 in] High Side

Dimensions = mm (in)

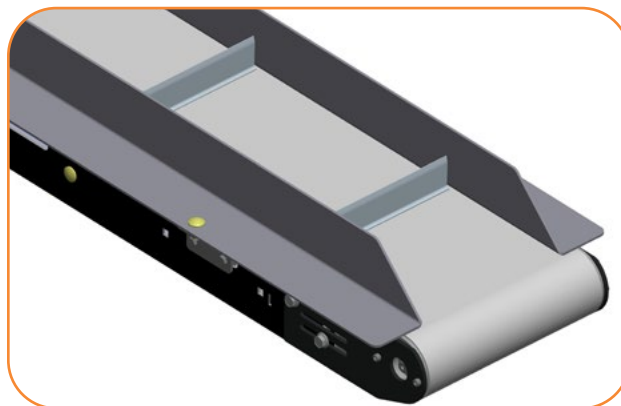

3 Guide
75 mm (3.00 in) High Side



Standard Belt Selection Guide

Standard belt material is stocked at Dorner, then cut & spliced at the factory for fast conveyor shipment.

Belt Type - Finger Splice	Belt Type - Plastic Clipper	Belt Type - Metal Clipper	Belt Specifications	Thickness	Surface Material	Carcass Material	Maximum Part Temperature	Coefficient of Friction	FDA Approved	Anti-Static	ESD	Chemical Resistance	Special Characteristics or Applications
01	A1	1A	FDA Accumulation	1.7 (0.067)	Urethane	Polyester	212°F (100°C)	Low	x	x		Good	Packaging, clean room and inspection
02	A2	2A	General Purpose	1.8 (0.071)	Urethane	Polyester	212°F (100°C)	Med	x	x		Good	Most versatile belt offering
03	A3	3A	FDA High Friction	1.7 (0.067)	Urethane	Polyester	212°F (100°C)	High	x	x		Good	Packaging, clean room and inspection
05	A5	5A	Accumulation	1.2 (0.047)	Urethane	Polyester	212°F (100°C)	V-Low	x	x		Good	Accumulation of products
06	A6	6A	Static Dissipative	1.6 (0.063)	Urethane	Polyester	176°F (80°C)	Low		x	x	Good	Electronics Handling
08	A8	8A	High Friction	2.1 (0.083)	PVC	Polyester	158°F (70°C)	V-High		x		Poor	Conveys up to 35° inclines*

Dim = mm (in)

Note: See below for splice details. Plastic Clipper splice requires longer lead times. Clipper splice not available on Z-Frame Series Conveyors.

Note: Conveyors wider than 40" (1,016 mm) require V-Guide belt tracking

Note: Belts with V-guiding may have a slight high spot or rib on the top surface. This rib would run longitudinally along the center of the belt. Consult factory with applications for which this may cause interference.

*Incline varies due to factors like dust, fluids and part material.

BELT SPLICING



Finger Splice

All belts are available with a standard Thermoformed finger splice. This splice makes the belt continuous and is virtually undetectable. Splice bonding methods vary by belt type. Consult factory for details.

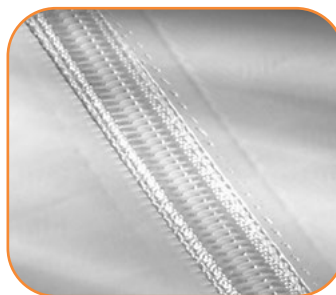

Plastic Clipper**

An optional plastic clipper splice is available for quick removal of belts or when conveyors are installed in tight spaces.

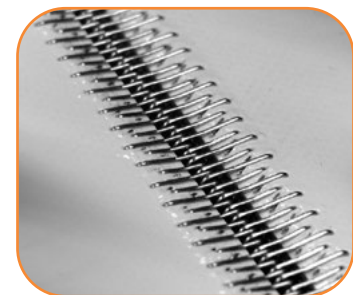

Metal Clipper**

An optional metal clipper splice is also available for quick removal of belts or when conveyors are installed in tight spaces.

** See belt charts for compatibility. Not for use with DCMove Nose Bar Transfer option. Plastic and Metal Clippers are slightly thicker than base belt. Contact factory for details.



Specialty Belt Selection Guide

Specialty belt material is not stocked at Dorner and needs to be custom ordered for your special conveyor needs.

Belt Type - Finger Splice	Belt Type - Plastic Clipper	Belt Type - Metal Clipper	Belt Specifications	V-Guideable	32 mm (1-1/4 in) Nose Bar	Belt Thickness	Surface Material	Maximum Part Temperature	Coefficient of Friction	FDA Approved	Anti-Static	Static Conductive	Chemical Resistance	Special Characteristics or Applications
18	B8	8B	Material Handling High Friction	X		2.0 (0.08)	PVC	158°F (70°C)	High		X		Poor	High friction, general product handling
50			Heat Resistant		X	1.3 (0.05)	Silicone	356°F (180°C)	Low		X		V-Good	High temperature
51			Heat Resistant Mesh			1.2 (0.05)	PTFE	550°F (288°C)	Low				V-Good	Product cooling
53			Translucent	X		0.5 (0.02)	Urethane	212°F (100°C)	V-Low	X			Good	Back lit inspection
54	F4	4F	FDA Sealed Edge**	X	X	1.5 (0.06)	Urethane	176°F (80°C)	Low	X	X		Good	Packaging, clean room and inspection
55	F5	5F	FDA Sealed Edge**	X	X	1.5 (0.06)	Urethane	176°F (80°C)	High	X	X		Good	Packaging, clean room and inspection
56		6F	Cut Resistant	X	X	2.1 (0.08)	Urethane	212°F (100°C)	Med.		X		Good	Oily product release, metal stamping
57		7F	Cut Resistant	X	X	2.5 (0.10)	Nitrile	176°F (80°C)	Med.		X		Poor	Felt-like, dry metal stamping, glass and ceramic
58		8F	Cut Resistant	X	X	1.6 (0.06)	Urethane	194°F (90°C)	Low		X		Good	Hard surface, gold colored
59	F9	9F	Color Contrasting	X	X	1.5 (0.06)	PVC	158°F (70°C)	Med.		X		Poor	Black colored, hides overspray from ink jet
60	G0	0G	Color Contrasting	X	X	1.3 (0.05)	Urethane	212°F (100°C)	Low	X	X		Good	Green colored
61	G1	1G	Color Contrasting	X	X	1.3 (0.05)	Urethane	212°F (100°C)	Med.	X	X		Good	Blue colored
63		3G	Electrically Conductive	X	X	1.2 (0.05)	Urethane	176°F (80°C)	V-Low		X	X	Good	Static conductive, electronics handling
64		4G	High Friction	X	X	4.4 (0.17)	PVC	176°F (80°C)	V-High		X		Poor	Dark Green colored, rough top surface, product cushioning, incline/decline apps
66		6G	Chemical Resistant	X	X	1.7 (0.07)	Polyester	212°F (100°C)	Med.	X	X		V-Good	Good cut resistance, metal stamping apps
68	G8		FDA Encased**	X	X	1.6 (0.06)	Urethane	176°F (80°C)	Low	X	X		Good	Urethane enclosed for added sanitary protection
69	G9		FDA Encased**	X	X	2.2 (0.09)	Urethane	176°F (80°C)	Med.	X	X		Good	Urethane enclosed for added sanitary protection
75			Black Urethane	X	X	1.5 (0.06)	Urethane	176°F (80°C)	Low		X		Good	
76			Black Nose bar	X	X	1.2 (0.05)	Urethane	176°F (80°C)	Med.		X		Good	Black Color, 8 mm (5/16 in) nose bar
77			High Friction, green	X	X	2.3 (0.09)	Urethane	212°F (100°C)	High		X		Good	Green color, high friction, urethane, grooved
78			Chemical, Polyolefin, HF	X		1.4 (0.06)	Polyolefin	140°F (60°C)	High	X			V-Good	Chemical resistant, food grade
79			Chemical, Polyolefin, LF	X		1.3 (0.05)	Polyolefin	140°F (60°C)	Med.	X	X		V-Good	Chemical resistant, food grade
80			High Friction, silicone	X	X	1 (0.04)	Silicone	176°F (80°C)	V-High	X			Good	Silicone material, high friction
81			Low Friction, silicone	X	X	0.9 (0.04)	Silicone	212°F (100°C)	Med.	X			Good	Silicone material, low to medium friction

Dim = mm (in)

Note: Clipper Splices not available on Z-Frame Series Conveyors.

Note: Conveyors wider than 1,016 mm (40 in) require V-Guide belt tracking

Note: Belts with V-Guiding may have a slight high spot or rib on the top surface. This rib would run longitudinally along the center of the belt. Consult factory with applications for which this may cause interference.

** Not available in 51 mm (2 in) widths

Cleated Belt Profiles

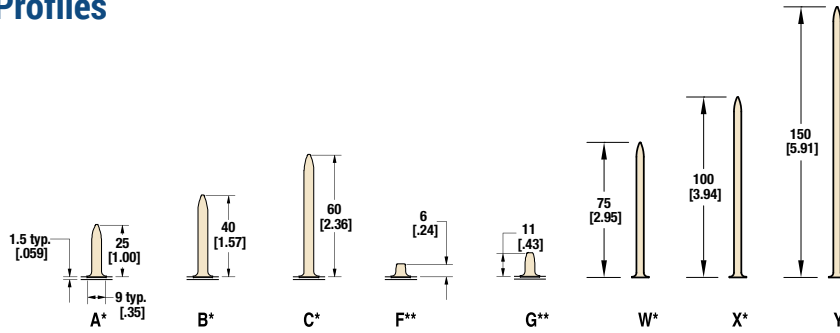

Cleated Belts									
Cleat Type	Base Belt	Belt Thickness	Surface Material	Color	Coefficient of Friction	V-Guided	Maximum Part Temperature	FDA Approved	Chemical Resistance
A,B,C,F,G	Standard Base Belt	1.4 (.055)	Urethane	White	High	X	212°F (100°C)	Yes	Good
A,B,C,F,G	Low Friction Base Belt	1.5 (0.06)	Urethane	Natural	Low	X	212°F (100°C)	Yes	Good
W,X,Y	Tall Cleated Base	2.2 (0.088)	Urethane	White	High	X	212°F (100°C)	Yes	Good
A,B,C	Wide Cleated Base	1.5 (0.06)	Urethane	White	Medium	X	212°F (100°C)	Yes	Good

Cleated Belt Spacing

- Minimum cleat spacing = 50 mm (2 in)
- Maximum cleat spacing for 457 mm (18 in) and wider conveyors = 508 (20 in)
- Maximum cleat spacing for 2.1 m (7 ft) and longer conveyors = 508 (20 in)
- 457 mm (18 in) and wider conveyors are limited to 2.1 m (7 ft) long
- X,Y,W cleats are limited to one section conveyors (2985 mm, 9.8 ft)
- A,B,C cleats width larger than 660 mm (26 in) are limited to one section conveyor (2985 mm, 9.8ft)

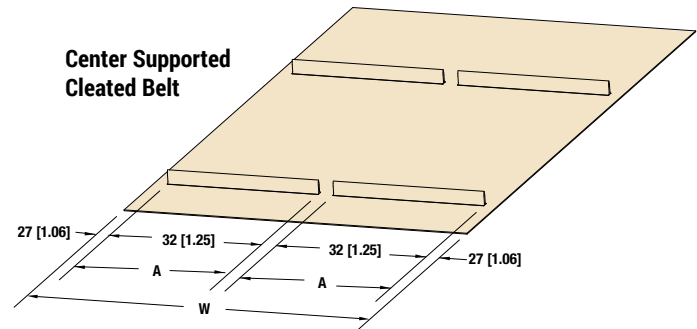
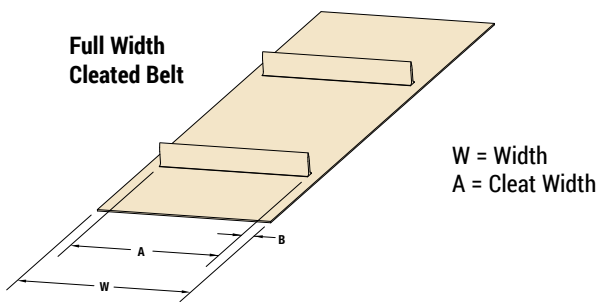
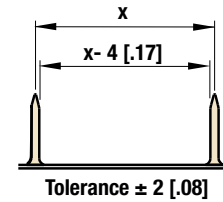

Width (W)	CLEAT TYPES	CLEAT WIDTH (A)	OFFSET/INSET(B)	Gap
10"	ALL	W-1.06*2	1.06	n/a
12"-24"	A,B,C,F,G	W-1.06*2	1.06	n/a
	X,Y,W	(W-1.06*2-1.25)/2	1.06	1.25
24" up	A,B, C	(W-1.06*2-1.25)/2	1.06	1.25

Side Mount Package, Parallel Shaft Gearmotor

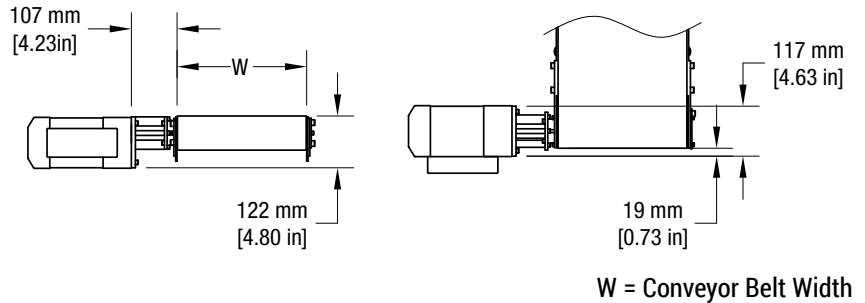

W = Conveyor Belt Width

- Includes gearmotor mounting bracket, 3 jaw flexible coupling, coupling guard and mounting hardware

Bottom Mount Package, Parallel Shaft Gearmotor

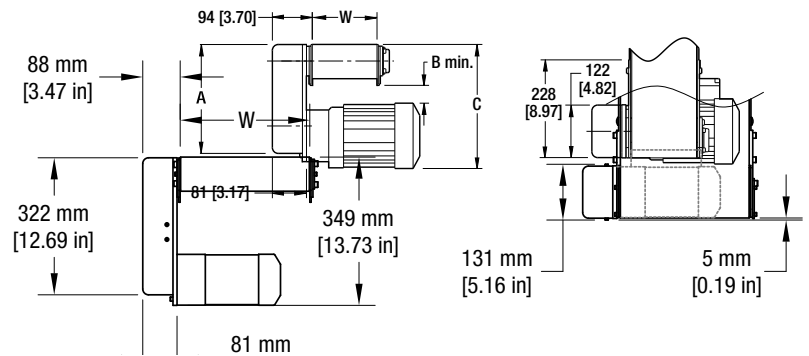

W = Conveyor Belt Width

- Includes gearmotor mounting bracket, timing belt, pulleys, guard and mounting hardware
- Conveyor belt speed can be adjusted with optional ratio pulley kits

For ordering information, see pages 23-24.

Side Mount Package, 90° Gearmotor

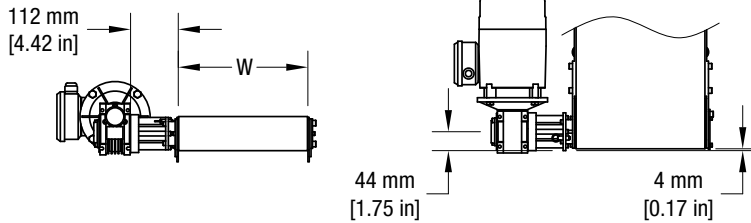
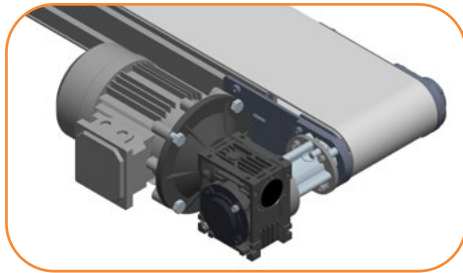

W = Conveyor Belt Width

- Includes gearmotor mounting bracket, 3-jaw flexible coupling, coupling guard and mounting hardware

Bottom Mount Package, 90° Gearmotor

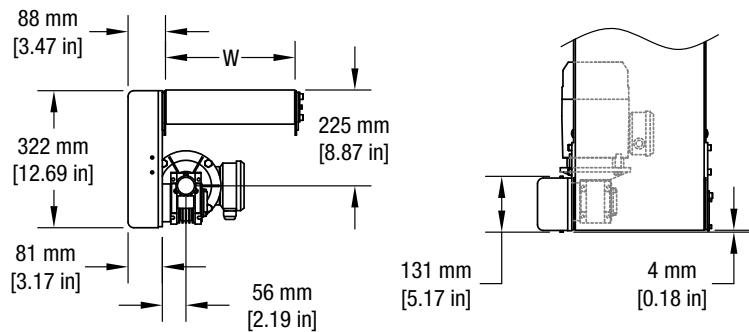

W = Conveyor Belt Width

- Includes gearmotor mounting bracket, timing belt, pulleys, guard and mounting hardware
- Conveyor belt speed can be adjusted with optional ratio pulley kits

90° Gearmotor Location Options

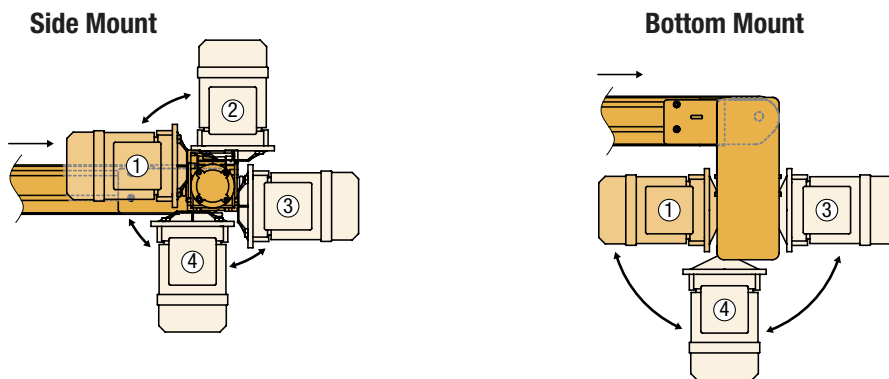

Note: Conveyor and gearmotor are not included in the mounting package and must be ordered separately. Dimensions = mm (in)

For ordering information, see pages 23-24.

End Drive Belt Speed

Fixed Speed							
DCMove Series		RPM From Gearmotor	Mount Package		Pulley Kit		Gearmotor Chart
m/min	Ft/min		Top & Bottom	Side	Drive Pulley	Driven Pulley	Standard Load
2.4	8	10	x	x	16	16	7
3.4	11	10	x		24	16	7
7.0	23	29	x	x	16	16	6, 7
10.4	34	43	x	x	16	16	6
11.3	37	47	x	x	16	16	21
14.0	46	58	x	x	16	16	7
15.9	52	43	x		24	16	6
21.0	69	86	x	x	16	16	6, 7
31.4	103	86	x		24	16	6, 7
33.0	107	134	x	x	16	16	21
41.8	137	173	x	x	16	16	6, 7
52.5	172	173	x		20	16	6, 7
62.8	206	173	x		24	16	6, 7
64.0	210	264	x	x	16	16	21
83.9	275	345	x	x	16	16	6, 7
104.6	343	345	x		20	16	6, 7
125.7	412	345	x		24	16	6, 7

Note: Cleated Belts operate at maximum 280 ft/min (86 m/min)
 Red = Parallel Shaft, Blue = 90°

Other speeds available. See www.dorner.com and run the DTools program for a full list of belt speeds.

Variable Speed								
DCMove Series		RPM From Gearmotor	Mount Package		Pulley Kit		Gearmotor Chart	
m/min	Ft/min		Top & Bottom	Side	Drive Pulley	Driven Pulley	Standard Load	
0.4 - 3.4	1.3 - 11	14	x	x	16	16	12	
0.6 - 5.2	2 - 17	14	x		24	16	12	
0.7 - 7	2.3 - 23	29	x	x	16	16	10, 13, 14	
1 - 10.4	3.4 - 34	43	x	x	16	16	10, 14	
1.2 - 10.1	4 - 33	42	x	x	16	16	9, 12	
1 - 11	4 - 37	47	x	x	16	16	22	
1.5 - 15.6	5 - 51	43	x		24	16	10, 14	
1.8 - 15.3	6 - 50	63	x	x	16	16	9	
2.1 - 20.7	7 - 68	86	x	x	16	16	10, 13, 14	
2.4 - 20.1	8 - 66	83	x	x	16	16	12	
3 - 23	9 - 75	63	x		24	16	9	
3 - 31	10 - 103	86	x		24	16	10, 13, 14	
3 - 33	11 - 107	134	x	x	16	16	22	
4 - 31	12 - 100	125	x	x	16	16	9, 12	
4 - 42	14 - 137	173	x	x	16	16	10, 13, 14	
5 - 46	18 - 150	125	x		24	16	9, 12	
6 - 63	21 - 206	173	x		24	16	10, 13, 14	
6 - 64	21 - 210	264	x	x	16	16	22	
7 - 61	24 - 200	250	x	x	16	16	9, 12	
8 - 84	27 - 275	345	x	x	16	16	10, 13, 14	
9 - 76	30 - 250	250	x		20	16	9, 12	
10 - 105	34 - 343	345	x		20	16	10, 13, 14	
11 - 92	36 - 300	250	x		24	16	9, 12	
13 - 126	41 - 412	345	x		24	16	10, 13, 14	
15 - 121	48 - 398	500	x	x	16	16	9	

DCMove: End Drive Mounting Packages

3 2 M B P S A - 1 6 1 6

- Drive / Driven Pulley Combination (Top and Bottom Mounts Only)
- Belt Style: "-" = Flat Belt or add Cleat Tyle: A, B, C, F, G, W, X, Y
- Gearmotor Mounting Position: A, B, C, D
- Gearmotor Type: L, V, S, H, K
- Gearmotor Output Shaft: P = Parallel Shaft, E = eDrive™, W = 90° SEW
- Mount Style: S = Side Mount, B = Bottom Mount
- Documentation Language: M = US, U = Europe
- Conveyor Series: 32 = DCMove

Example: 32MBPSA-1616

Description: Bottom mount package with English documentation. Configured for a parallel shaft, standard load motor in the A mount position with a 16:16 drive / driven pulld combination.

Drive Shaft Position

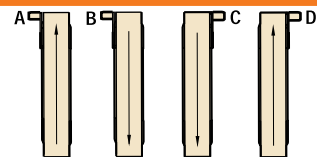

Since belts are being pulled, positions A & D are preferred. Pushing belts (B & C) reduce conveyor load capacity by approximately 66%.

Refer to the Gearmotor Selection Steps on page 25.

Center Drive Belt Speed

Fixed Speed			
Belt Speed		RPM From Gearmotor	Gearmotor Chart #
m/min	Ft/min		
6.4	21	13	22
8.4	28	17	15
10.5	35	22	15
14.0	46	29	15
16.8	55	35	15
18.0	61	38	22
21.0	69	43	15
28.0	92	58	15
33.7	110	70	15
42.1	138	86	15
52.0	170	106	22
56.1	184	115	15
84.1	276	173	15
98.0	321	201	22
112.2	368	230	15

Variable Speed			
Belt Speed		RPM From Gearmotor	Gearmotor Chart #
m/min	Ft/min		
0.8 - 8.4	2.8 - 28	17	18, 19
1 - 6.4	3.5 - 21	13	23
1.1 - 10.5	3.5 - 35	22	18
1.2 - 12.2	4 - 40	25	17
1.4 - 14.0	4.6 - 46	29	18, 19
1.5 - 15.2	5 - 50	31	17
1.7 - 16.8	5.5 - 55.2	35	18
2.0 - 20.3	6.7 - 66.7	42	17
2.1 - 21.0	6.9 - 69	43	18, 19
2.8 - 28.0	9.2 - 92	58	18
3 - 18	10 - 61	38	23
3.4 - 33.7	11 - 110.4	70	18, 19
4.2 - 42.1	13.8 - 138	86	18, 19
5.6 - 56.0	18.4 - 184	115	18, 19
8.4 - 84.1	27.6 - 276	173	18
9 - 52	28 - 170	106	23
16 - 98	53 - 321	201	23
11.2 - 112.2	36.8 - 368	230	18

Other speeds available.

Go to <http://tools.dornerconveyors.com/> to configure a conveyor for a full list of belt speeds.

DCMove: Center Drive Mounting Packages

3 2 M B P S A - 1 6 1 6

- Drive / Driven Pulley Combination (Top and Bottom Mounts Only)
- Belt Style: "-" = Flat Belt or add Cleat Tyle: A, B, C, F, G, W, X, Y
- Gearmotor Mounting Position: A, B, C, D
- Gearmotor Type: L, V, S, H, K
- Gearmotor Output Shaft: P = Parallel Shaft, E = eDrive™, W = 90° SEW
- Mount Style: S = Side Mount, B = Bottom Mount
- Documentation Language: M = US, U = Europe
- Conveyor Series: 32 = DCMove

Example: 32MBPSA-1616
Description: Bottom mount package with English documentation. Configured for a parallel shaft, standard load motor in the A mount position with a 16:16 drive / driven pulld combination.

Drive Shaft Position

Since belts are being pulled, positions A & D are preferred. Pushing belts (B & C) reduce conveyor load capacity by approximately 66%.

Standard Load, Fixed Speed

Chart 6
90° eDrive NEMA C-Face

- Sealed gearmotors
- NEMA 56 C face
- Totally enclosed, fan cooled
- 115V 1 phase includes switch, cord and overload protection
- 208-230/460 Volts 3 phase wiring by others
- 60 Hz
- Order 3 phase starter separately, see page 72

Regulatory Approvals

Part Number	RPM	Gearmotor Type	1 Phase			3 Phase			in.-lbs.	Nm	Starter Chart
			Hp	kW	FLA	Hp	kW	FLA			
32M060ES4(vp)FN	29	S	0.5	0.37	5.7	0.5	0.37	1.76-1.71 / 1.14	319	36	M
32M040ES4(vp)FN	43	S	0.5	0.37	5.7	0.5	0.37	1.76-1.71 / 1.14	378	42.7	M
32M020ES4(vp)FN	86	S	0.5	0.37	5.7	0.5	0.37	1.76-1.71 / 1.14	285	32.2	M
32M010ES4(vp)FN	173	S	0.5	0.37	5.7	0.5	0.37	1.76-1.71 / 1.14	153	17.3	M

(vp) = Voltage and Phase 11 = 115V, 1 phase 23 = 208 - 230 / 460V, 3 phase

Chart 7
Parallel Shaft NEMA

- Sealed gearmotor
- Totally enclosed, fan cooled
- 115V 1 phase includes switch, cord and overload protection
- 230V 3 phase wiring by others
- 60 Hz
- Order 3 phase starter separately, see page 72

Regulatory Approvals

Part Number	RPM	Gearmotor Type	1 Phase			3 Phase			in.-lbs.	Nm	Starter Chart
			Hp	kW	FLA	Hp	kW	FLA			
62M180PS4(vp)FN	10	S	0.08	0.06	1.2	.17	0.13	1.0	341	38.5	L
62M060PS4(vp)FN	29	S	0.17	0.13	1.9	.17	0.13	1.0	270	30.5	L
(x)2M030PS4(vp)FN	58	S	0.33	0.25	4	.38	0.28	1.9	250	28.3	M
(x)2M020PS4(vp)FN	86	S	0.33	0.25	4	.38	0.28	1.9	167	18.9	M
(x)2M010PS4(vp)FN	173	S	0.33	0.25	4	.38	0.28	1.9	108	12.2	M
(x)2M005PS4(vp)FN	345	S	0.33	0.25	4	.38	0.28	1.9	56	6.3	M

(vp) = Voltage and Phase 11 = 115V, 1 phase 23 = 208 - 230 / 460V, 3 phase (x) = 3 for 1 phase, 6 for 3 phase

FLA = Full Load Amperes

Some motors and gear reducers may normally operate hot to the touch. Consult factory for specific operating temperatures. Note: Dimensions = mm

(in)

Standard Load, Fixed Speed (continued)

Chart 8		90° eDrive IEC C-Face						
<ul style="list-style-type: none"> • Sealed gearmotor • IEC 71 B5 C face for 0.37 kW Motor • IEC 63 B5 C face for 0.18 kW Motor • IP55 protection rating • Order starter separately, see page 72 • Totally enclosed, fan cooled • Non-reversible • 50 Hz 							<p>Regulatory Approvals</p>	
Part Number	RPM	Gearmotor Type	1Ph kW	1 Ph FLA	3 Ph kW	3 Ph FLA	Nm	Starter Chart
62Z060ES4(vp)FN	23	L	0.18	1.6	0.25	1.56 / 0.90	36/36	I
62Z040ES4(vp)FN	35	L	0.18	1.6	0.25	1.56 / 0.90	26.9/35.5	I
32Z020ES4(vp)FN	70	S	0.37	2.6	0.37	2.1 / 1.2	32.2	J
32Z010ES4(vp)FN	140	S	0.37	2.6	0.37	2.1 / 1.2	17.3	J
32Z005ES4(vp)FN	280	S	0.37	2.6	0.37	2.1 / 1.2	9	J

(vp) = Voltage and Phase 21 = 230V, 1 phase 23 = 230V / 460V, 3 phase 43 = 400V, 3 phase

Chart 20		90° SEW						
<ul style="list-style-type: none"> • SEW SA37 Gearmotor • Bottom and side mount packages available • 230 / 460 V 3 Phase • VFD Compatible with constant torque from 10 to 60 Hz • Sealed gear head, totally enclosed fan cooled motor 							<p>Regulatory Approvals</p>	
Part Number	RPM*	Gearmotor Type	Hp	kW	FLA	in-lbs	Nm	Starter Chart
32M038WS423EN	47	W	0.50	0.37	1.84 / 0.92	548	61.9	M
32M013WS423EN	134	W	0.75	0.56	2.50 / 1.25	327	37.0	M
32M007WS423EN	264	W	1.00	0.75	2.90 / 1.44	221	25.0	P

(vp) = Voltage and Phase 21 = 230V, 1 phase 23 = 230V / 460V, 3 phase 43 = 400V, 3 phase

FLA = Full Load Amperes

Some motors and gear reducers may normally operate hot to the touch. Consult factory for specific operating temperatures. Note: Dimensions = mm (in)

CE Note: When buying a gearmotor only without the starter, the customer must supply their own on/off switch and motor overload protection to comply with the CE Safety Directive.

Standard Load, Variable Speed

Chart 9		90 NEMA C-Face DC°							Regulatory Approvals
<ul style="list-style-type: none"> • 90V DC • Sealed gearmotor • NEMA 56 C Face • Totally enclosed, fan cooled • Order controller separately, see page 70 									
Part Number	RPM	Gearmotor Type	Hp	kW	FLA	in.-lbs.	Nm	Vari-Speed Control Chart	
32M060ESD9DEN	42	S	0.5	0.37	5.0	319	36	C	
32M040ESD9DEN	63	S	0.5	0.37	5.0	378	42.7	C	
32M020ESD9DEN	125	S	0.5	0.37	5.0	285	32.2	C	
62M005EHD9DEN	250	S	0.75	0.5	7.5	108	12.2	C	

Chart 10		90° eDrive NEMA C-Face VFD Rated							Regulatory Approvals
<ul style="list-style-type: none"> • Variable frequency drive, 6 - 60 Hz • Sealed gearmotor • NEMA 56 C Face • Totally enclosed, fan cooled • 230/460 Volts, 3 Phase • Order controller separately, see page 70 									
Part Number	RPM*	Gearmotor Type	3 Ph Hp	3 Ph kW	3 Ph FLA	in.-lbs.*	Nm*	Vari-Speed Control Chart	
32M060ES423EN	29	S	0.75**	0.55	2.6 / 1.3	319	36	D and E	
32M040ES423EN	43	S	0.75**	0.55	2.6 / 1.3	378	42.7	D and E	
32M020ES423EN	86	S	0.75**	0.55	2.6 / 1.3	285	32.2	D and E	
32M010ES423EN	173	S	0.75**	0.55	2.6 / 1.3	153	17.3	D and E	

* = At 60 Hz ** = Motor is de-rated to 0.5 Hp for full torque throughout the speed range.

FLA = Full Load Amperes

Some motors and gear reducers may normally operate hot to the touch. Consult factory for specific operating temperatures. Note: Dimensions = mm (in)

Standard Load, Variable Speed (continued)

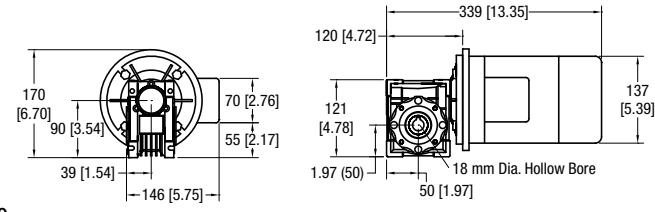
Chart 11		90° eDrive IEC C-Face VFD Rated					Regulatory Approvals 
<ul style="list-style-type: none"> • Variable frequency drive, 25 - 63 Hz • Sealed gearmotor • IEC 63 B5 C Face for 0.18 kW Motor • IEC 71 B5 C Face for 0.37 kW Motor • IP 55 protection rating • Totally enclosed, fan cooled • 230/400 Volts, 3 Phase • Order controller separately, see page 70 							
Part Number	RPM	Gearmotor Type	3 Ph kW	3 Ph FLA	Nm*	Vari-Speed Control Chart	
62Z060ES423EN	23	L	0.25	1.56 / 0.90	36	B	
62Z040ES423EN	35	L	0.25	1.56 / 0.90	35.5	B	
32Z020ES423EN	70	S	0.37	2.1 / 1.2	32.2	B	
32Z010ES423EN	140	S	0.37	2.1 / 1.2	17.3	B	
32Z005ES423EN	280	S	0.37	2.1 / 1.2	9	B	

* = At 50 Hz

CE Note: When buying a gearmotor only without the starter, the customer must supply their own on/off switch and motor overload protection to comply with the CE Safety Directive.

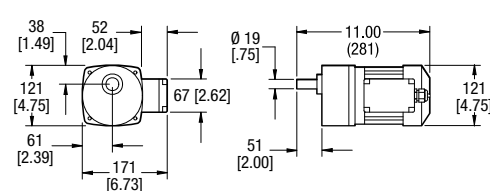
Chart 13		Parallel Shaft NEMA VFD Rated					Regulatory Approvals 	
<ul style="list-style-type: none"> • Variable frequency drive, 10 to 60 Hz • Sealed gearmotor • Totally enclosed, fan cooled • 230/460 Volts / 3 Phase, VFD duty • Order controller separately, see page 70 								
Part Number	RPM	Gearmotor Type	Hp	kW	FLA	in.-lbs.	Nm	Vari-Speed Control Chart
62M180PS423EN	10	S	0.17	0.13	1.0	341	38.5	D and E
62M060PS423EN	29	S	0.17	0.13	1.0	270	30.5	D and E
62M030PS423EN	58	S	0.38	0.28	1.9	250	28.3	D and E
62M020PS423EN	86	S	0.38	0.28	1.9	167	18.9	D and E
62M010PS423EN	173	S	0.38	0.28	1.9	115	13.0	D and E

FLA = Full Load Amperes

Some motors and gear reducers may normally operate hot to the touch. Consult factory for specific operating temperatures. Note: Dimensions = mm (in)

Standard Load, Variable Speed (continued)

Chart 21		90° Sew VFD Rated							Regulatory Approvals CE UL SP
<ul style="list-style-type: none"> • SEW SA37 Gearmotor • Bottom and side mount packages available • 230 / 460 V 3 Phase • VFD Compatible with constant torque from 10 to 60 Hz • Sealed gear head, totally enclosed fan cooled motor 									
Part Number	RPM*	Gearmotor Type	Hp	kW	FLA	in.-lbs	Nm	Vari-Speed Control Chart	
32M038WS423EN	47	W	0.50	0.37	1.84 / 0.92	548	61.9	D or E	
32M013WS423EN	134	W	0.75	0.56	2.50 / 1.25	327	37.0	D or E	
32M007WS423EN	264	W	1.00	0.75	2.90 / 1.44	221	25.0	D	

Heavy Load, Fixed Speed

Chart 15		90° eDrive NEMA C-Face							Regulatory Approvals CE UL SP RoHS		
<ul style="list-style-type: none"> • NEMA 56 C face for .5 & 1 Hp • NEMA 145TC C face for 1.5 Hp • NEMA 145TC C face for 2 Hp • Totally enclosed, fan cooled • 115V, 1 Phase includes switch, cord and overload protection • 208 - 230/460 Volts, 3 Phase wiring by others • 60 Hz • Order 3 phase starter separately, see page 72 											
Part Number	RPM	Gearmotor Type	1 Phase			3 Phase			in.-lbs.	Nm	3 Phase Starter Chart
			Hp	kW	FLA	Hp	kW	FLA			
32M100EH4(vp)FN	17	H	0.5	0.37	8.0	0.5	0.37	2.0 / 1.0	913	103	M
32M080EH4(vp)FN	22	H	0.5	0.37	8.0	0.5	0.37	2.0 / 1.0	833	94	M
32M060EH4(vp)FN	29	H	0.5	0.37	8.0	0.5	0.37	2.0 / 1.0	679	76	M
32M050EH423FN	35	H	n/a	n/a	n/a	1.0	0.74	3.4 / 1.7	1205	136	P
32M040EH423FN	43	H	n/a	n/a	n/a	1.0	0.74	3.4 / 1.7	1023	115	P
32M030EH423FN	58	H	n/a	n/a	n/a	1.5	1.11	5.0 / 2.5	1216	137	Q
32M025EH423FN	70	H	n/a	n/a	n/a	1.5	1.11	5.0 / 2.5	1068	121	Q
32M020EH423FN	86	H	n/a	n/a	n/a	2.0	1.49	6.2 / 3.1	1183	134	Q
32M015EH423FN	115	H	n/a	n/a	n/a	2.0	1.49	6.2 / 3.1	909	103	Q
32M010EH423FN	173	H	n/a	n/a	n/a	2.0	1.49	6.2 / 3.1	636	72	Q
32M008EH423FN	230	H	n/a	n/a	n/a	2.0	1.49	6.2 / 3.1	482	54	Q

FLA = Full Load Amperes

Some motors and gear reducers may normally operate hot to the touch. Consult factory for specific operating temperatures. Note: Dimensions = mm (in)

Heavy Load, Fixed Speed (continued)

Chart 16 90° eDrive IEC C-Face

- Sealed gearmotor
- IP55 protection rating
- 50 Hz
- IEC B5 C face mount (see table for size)
- Totally enclosed, fan cooled
- Order starter separately, see page 72

Regulatory Approvals: CE, RoHS

Part Number	RPM	Gearmotor Type	Belt Speed		Motor Face	Hp	kW	FLA	in-lbs	Nm	Starter Chart
			ft/min	m/min							
52Z100EH423FN	14	H	14	4.3	71	0.5	0.37	2.1 / 1.2	1142	129	J
52Z080EH423FN	18	H	18	5.3	71	0.5	0.37	2.1 / 1.2	1018	115	J
52Z050EH423FN	28	H	28	8.5	80	0.7	0.55	2.6 / 1.5	1097	124	R
52Z040EH423FN	35	H	35	10.7	80	0.7	0.55	2.6 / 1.5	929	105	R
52Z030EH423FN	47	H	47	14.2	90	1.5	1.10	4.7 / 2.7	1478	167	K
52Z020EH423FN	70	H	70	21.3	90	1.5	1.10	4.7 / 2.7	1080	122	K
52Z015EH423FN	93	H	93	28.4	90	2.0	1.50	6.1 / 3.5	1124	127	K
52Z010EH423FN	140	H	140	42.7	90	2.0	1.50	6.1 / 3.5	788	89	K
52Z008EH423FN	187	H	187	56.9	90	2.0	1.50	6.1 / 3.5	602	68	K

23 = 230V, 3 phase 43 = 430V, 3 phase
Note: LPZ Conveyors are not reversible

CE Note: When buying a gearmotor only without the starter, the customer must supply their own on/off switch and motor overload protection to comply with the CE Safety Directive.

Chart 22 90° SEW

- SEW SA47 Gearmotor
- Center mount packages only
- 230 / 460 V 3 Phase
- VFD Compatible with constant torque from 10 to 60 Hz
- Sealed gear head, totally enclosed fan cooled motor

Regulatory Approvals: CE, RoHS

Part Number	RPM*	Gearmotor Type	Hp	kW	FLA	in-lbs	Nm	Starter Chart
32M128WH423EN*	13	W	0.33	0.25	1.14 / 0.57	991	112.0	L
32M044WH423EN*	38	W	0.75	0.56	2.50 / 1.25	973	109.9	M
32M016WH423EN*	106	W	1.50	1.12	4.50 / 2.25	787	88.9	Q
32M008WH423EN*	201	W	2.00	1.49	5.70 / 2.85	575	65.0	Q

* 20 day lead time required

FLA = Full Load Amperes

Some motors and gear reducers may normally operate hot to the touch. Consult factory for specific operating temperatures. Note: Dimensions = mm (in)

Heavy Load, Variable Speed

Chart 18
90° eDrive NEMA C-Face VFD Rated

- Variable frequency drive, 15 - 60 Hz
- NEMA 56 C face for .5 Hp + 1 Hp
- NEMA 145TC C face for 1.5 + 2 Hp
- Totally enclosed, fan cooled
- 230/460 Volts, 3 phase
- Order controller separately, see page 70

Technical drawings showing front and side views of the gearmotor with dimensions in mm and inches. Front view dimensions: 235 [9.25] (width), 135 [5.31] (height), 2.20 [56] (width), 227 [8.94] (height). Side view dimensions: 496 [19.53] (total length), 177 [6.97] (length to center), 184 [7.25] (height), 174 [6.85] (height to center), 72 [2.83] (width to center).

Regulatory Approvals

Part Number	RPM	Gearmotor Type	Hp	kW	FLA	in.-lbs.*	Nm*	Vari-Speed Control Chart
32M100EH423EN	17	H	0.5	0.37	1.6 / 0.8	913	103	D or E
32M080EH423EN	22	H	0.5	0.37	1.6 / 0.8	833	94	D or E
32M060EH423EN	29	H	0.5	0.37	1.6 / 0.8	679	76	D or E
32M050EH423EN	35	H	1.0	0.74	3.2 / 1.6	1205	136	D
32M040EH423EN	43	H	1.0	0.74	3.2 / 1.6	1023	115	D
32M030EH423EN	58	H	1.5	1.11	4.2 / 2.1	1216	137	D
32M025EH423EN	70	H	1.5	1.11	4.2 / 2.1	1068	121	D
32M020EH423EN	86	H	2.0	1.49	5.0 / 2.5	1183	134	D
32M015EH423EN	115	H	2.0	1.49	5.0 / 2.5	909	103	D
32M010EH423EN	173	H	2.0	1.49	5.0 / 2.5	636	72	D
32M008EH423EN	230	H	2.0	1.49	5.0 / 2.5	482	54	D

* = At 60 Hz

FLA = Full Load Amperes

Some motors and gear reducers may normally operate hot to the touch. Consult factory for specific operating temperatures. Note: Dimensions = mm (in)

Heavy Load, Variable Speed (continued)

Chart 19 90° eDrive IEC C-Face, VFD Rated

- Variable frequency drive, 25 to 63 Hz
- Sealed gearmotor
- IP55 protection rating
- 230/400 Volts, 50 Hz nominal
- IEC B5 C face mount (see table for size)
- Totally enclosed, fan cooled
- Order controller separately, see page 70

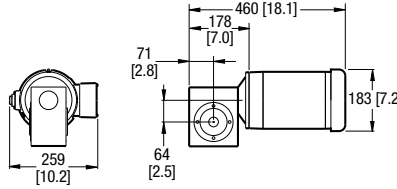

Regulatory Approvals



Part Number	RPM	Gearmotor Type	Belt Speed		Motor Face	Hp	kW	FLA	in-lbs	Nm	Controller Chart
			ft/min	m/min							
52Z100HH423EN	7 to 18	H	7 to 18	2 to 5	71	0.5	0.37	2.1 / 1.2	1142	129	B
52Z080HH423EN	9 to 22	H	9 to 22	3 to 7	71	0.5	0.37	2.1 / 1.2	1018	115	B
52Z050HH423EN	14 to 35	H	14 to 35	4 to 11	80	0.7	0.55	2.6 / 1.5	1097	124	B
52Z040HH423EN	18 to 44	H	18 to 44	5 to 13	80	0.7	0.55	2.6 / 1.5	929	105	B
52Z030HH423EN	23 to 59	H	23 to 59	7 to 18	90	1.5	1.10	4.7 / 2.7	1478	167	B
52Z020HH423EN	35 to 88	H	35 to 88	11 to 27	90	1.5	1.10	4.7 / 2.7	1080	122	B
52Z015HH423EN	47 to 118	H	47 to 118	14 to 36	90	2.0	1.50	6.1 / 3.5	1124	127	B
52Z010HH423EN	70 to 176	H	70 to 176	21 to 54	90	2.0	1.50	6.1 / 3.5	788	89	B
52Z008HH423EN	93 to 235	H	93 to 235	28 to 72	90	2.0	1.50	6.1 / 3.5	602	68	B

23 = 230V, 3 phase 43 = 430V, 3 phase

FLA = Full Load Amperes

Note: LPZ Conveyors are not reversible

CE Note: When buying a gearmotor only without the starter, the customer must supply their own on/off switch and motor overload protection to comply with the CE Safety Directive.

Chart 23 90° SEW VFD Rated

- SEW SA47 Gearmotor
- Center mount packages only
- 230 / 460 V 3 Phase
- VFD Compatible with constant torque from 10 to 60 Hz
- Sealed gear head, totally enclosed fan cooled motor

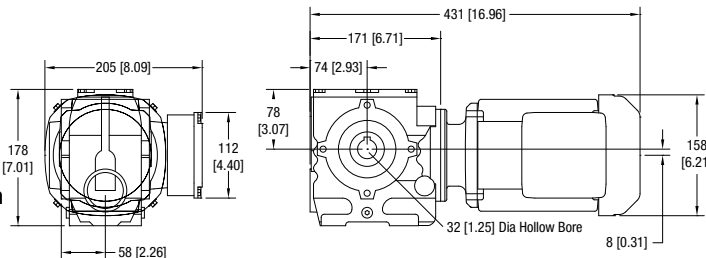

Regulatory Approvals



Part Number	RPM*	Gearmotor Type	Hp	kW	FLA	in-lbs	Nm	Vari-Speed Control Chart
32M128WH423EN*	13	W	0.33	0.25	1.14 / 0.57	991	112.0	D or E
32M044WH423EN*	38	W	0.75	0.56	2.50 / 1.25	973	109.9	D or E
32M016WH423EN*	106	W	1.50	1.12	4.50 / 2.25	787	88.9	D
32M008WH423EN*	201	W	2.00	1.49	5.70 / 2.85	575	65.0	D

* 20 day lead time required

FLA = Full Load Amperes

Some motors and gear reducers may normally operate hot to the touch. Consult factory for specific operating temperatures. Note: Dimensions = mm (in)

Control Product Family



Manual Motor Starter

(see page 36)

Provides motor overload protection and lockout/tagout capability



Basic VFD Control

(see page 35)

Simple on/off, direction, and speed control right at the side of the conveyor



Full Feature VFD Control

(see page 35)

All the features of a Basic VFD with options to control remotely from a Dorner accessory, discrete I/O, or using a variety of industrial network protocols



Full Feature VFD with Accessory

(see page 35)

Full feature control with M12 Accessory port for a variety of applications



iDrive Motor Control

(see pages 10 & 12)

Brushless DC Controls, 24VDC with preset speeds programed ready to use package. Variety of configuration available

Variable Speed Controllers

Chart A						
<ul style="list-style-type: none"> • PWM DC control • Nema 1 enclosure • Line cord and motor cord • On/Off switch for 62MD1134 • Forward/Off/Reverse switch for 62MD1134R • Speed potentiometer • Mounting hardware 						
Part Number	Input Volts	Input Phase	Input Hz	Output Volts	Max Amps*	Reversing
62MD1134	115	1	60	130VDC	3.2	No
62MD1134R	115	1	60	130VDC	5.0	Yes

Chart C Brush-Type DC Controller							
<ul style="list-style-type: none"> • PWM DC control • NEMA 1 enclosure • Line cord and motor cord • On/Off switch for 62MD1192 and 62MD1193 • Forward/Off/Reverse switch for 62MD1192R and 62MD1193R • Speed potentiometer • Mounting hardware 						<p>Regulatory Approvals</p> <p>RoHS</p>	
Part Number	Input Volts	Input Phase	Input Hz	Output Volts	Max Amps*	Reversing	
62MD1192	115	1	60	90VDC	5.0	No	
62MD1192R	115	1	60	90VDC	5.0	Yes	
62MD1193	115	1	60	90VDC	7.5	No	
62MD1193R	115	1	60	90VDC	7.5	Yes	

Variable Speed Controllers (continued)

Chart D		Full Feature VFD Controller						
<ul style="list-style-type: none"> • Full feature VFD control • IP65 plastic enclosure • Digital display • Keypad with Start/Stop, Forward/Reverse and speed variations • Includes cord to motor • Power to controller by others • Mounting hardware 							<p>Regulatory Approvals</p> <p>CE</p> <p>cULus</p>	
Part Number	Input Volts	Input Phase	Input Hz	Output Volts	Output Phase	Max Hp	Output Amps*	Reversing
32MVA1122(O)	115	1	60	230	3	0.5	2.3	Yes
32MVA2122(O)	230	1	60	230	3	0.5	2.3	Yes
32MVA1121(O)	115	1	60	230	3	1.0	4.3	Yes
32MVA2121(O)	230	1	60	230	3	1.0	4.3	Yes
32MVA2127(O)	230	1	60	230	3	2.0	7.0	Yes
32MVA2322(O)	230	3	60	230	3	0.5	4.3	Yes
32MVA2321(O)	230	3	60	230	3	1.0	2.3	Yes
32MVA2327(O)	230	3	60	230	3	2.0	7.0	Yes
32MVA4342(O)	460	3	60	460	3	0.5	1.2	Yes
32MVA4341(O)	460	3	60	460	3	1.0	2.2	Yes
32MVA4347(O)	460	3	60	460	3	2.0	4.1	Yes
<p>In order for this drive to meet full CE requirements for European application a separate CE approve RFI filter must be installed. Product shown in chart B above have this filter pre-installed and are recommended for use in the European Union.</p> <p>(O) = Optional M12 Accessory Port No Option = No Accessory Port E = M12 Port wired for End Stop Photo Eye Application I = M12 port wired for Index Photo Eye Application Note: E or I options will work with Dornier Control Stop or Jog Button Accessories</p>								

Chart E		Basic VFD Controller						
<ul style="list-style-type: none"> • Variable Speed Drive • On/off buttons and knob for speed on keypad • Direction setting via parameter change • Includes mounting bracket that can mount drive to vertical or horizontal T-slot • Includes 10ft input power cord with three prong standard 120V outlet plug • Includes 10ft motor output cord for 3 phase motor connection with flying leads • IP 20 rating with electrical finger safe connections • Pre-programed to match motor parameters and locked parameter settings for ease of uses • cULus and CE compliant 							<p>Regulatory Approvals</p> <p>CE</p> <p>RoHS</p> <p>cULus</p>	
Part Number	Input Volts	Input Phase	Input Hz	Output Volts	Output Phase	Max Hp	Max Amps	Reversing
22MV1126T	115	1	60	230	3	0.125-0.5	2.6	Yes*

*Reversing is controlled by parameter change

* = See FLA from motor charts Note: Dimensions = mm (in)

Manual Motor Starters

=

Manual motor starters are manual electronic disconnects that provide motor overload protection and are required by the National Electric Code (NEC) for safe motor operation.

- IP 55 Enclosure
- Push button Start / Stop
- Includes mounting hardware

Regulatory Approvals



Illustration A

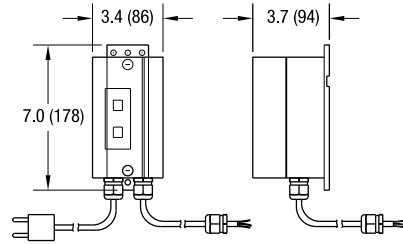

Illustration B

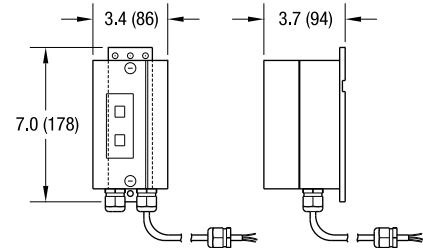

Chart M		230/460V 60Hz to 2.5 amp		
<ul style="list-style-type: none"> • 230/460 Volts, 3 phase wiring to starter by others • Wiring between motor and starter provided when ordered together • 60 Hz 				
Part Number	In Volts	In Phase	Amp Range	Illustration
62MM23M	208 -	3	1.6 - 2.5	B
62MM43M	230 460	3	1.0 - 1.6	B

Chart L		230/460V 60 Hz to 1.6 amp		
<ul style="list-style-type: none"> • 230/460 Volts, 3 phase wiring to starter by others • Wiring between motor and starter provided when ordered together • 60 Hz 				
Part Number	In Volts	In Phase	Amp Range	Illustration
62MM23L	230	3	1.0 - 1.6	B
62MM43L	460	3	0.4 - .63	B

Chart Q		230/460V 60Hz to 6.3 amp		
<ul style="list-style-type: none"> • 230/460 Volts, 3 phase wiring to starter by others • Wiring between motor and starter provided when ordered together • 60 Hz 				
Part Number	In Volts	In Phase	Amp Range	Illustration
62MM23Q	208 -	3	4.0 - 6.3	B
62MM43Q	230 460	3	2.5 - 4.0	B

Chart P		230/460V 60Hz to 4 amp		
<ul style="list-style-type: none"> • 230/460 Volts, 3 phase wiring to starter by others • Wiring between motor and starter provided when ordered together • 60 Hz 				
Part Number	In Volts	In Phase	Amp Range	Illustration
62MM23U	208 -	3	2.5 - 4.0	B
62MM43P	230 460	3	1.6 - 2.5	B

CE Note: When buying a gearmotor only without the starter, the customer must supply their own on/off switch and motor overload protection to comply with NEC and CE safety directive.

(c) = Electrical Configuration G = CE German
 F = CE French U = CE Great Britain **Note:** Dimensions = mm (in)

Fixed Height Supports Stands

Fixed Foot Model			
Stand Width (WWWW)	254 mm (10 in)	51 mm (2 in) increments up to...	1219 mm (48 in)
Part # Reference	0254	in 51 increments up to...	1219
Stand Height (HHHH)*	600 - 700 mm (24 - 28 in)	25 mm (1 in) increments up to...	1900 - 2000 mm (75 - 79 in)
Part # Reference Belt	0600-0700	in 0025 increments up to...	1900-2000

* Top of Belt Measurement

Swivel Locking Caster Model			
Stand Width (WWWW)	254 mm (10 in)	51 mm (2 in) increments up to...	1219 mm (48 in)
Part # Reference	0254	in 51 increments up to...	1219
Stand Height (HHHH)*	725 - 825 mm (29 - 33 in)	in 25 mm (1 in) increments up to...	1900 - 2000 mm (75 - 79 in)
Part # Reference	0725-0825	in 0025 increments up to...	1900-2000

* Top of Belt Measurement

- 100 mm (4 in) Height Adjustment
- Provides most access to outside T-Slots
- Support stands can be moved on 150mm increments depending on conveyor configuration

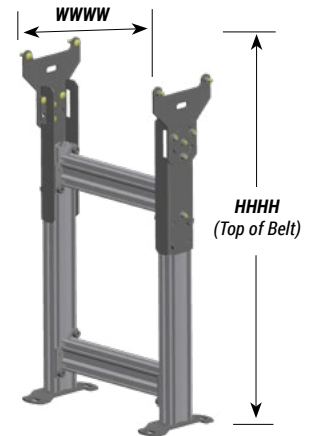

*Outrigger is used when conveyor height to width ratio exceeds 3.5, and on side drive motor mount packages.

Short Support Stands

Fixed Foot Model			
Stand Width (WWWW)	254 mm (10 in)	51 mm (2 in) increments up to...	1219 mm (48 in)
Part # Reference	0254	in 51 increments up to...	1219
Stand Height (HHHH)*	350 - 400 mm (14 - 16 in)	in 25 mm (1 in) increments up to...	600 - 650 mm (24 - 26 in)
Part # Reference	0350-0400	in 0025 increments up to...	0600-0650

* Top of Belt Measurement

Swivel Locking Caster Model			
Stand Width (WWWW)	254 mm (10 in)	51 mm (2 in) increments up to...	1219 mm (48 in)
Part # Reference	0254	in 51 increments up to...	1219
Stand Height (HHHH)*	475 - 525 mm (19 - 21 in)	in 25 mm (1 in) increments up to...	700 - 750 mm (28 - 30 in)
Part # Reference	0475-0525	in 0025 increments up to...	0700-0750

* Top of Belt Measurement

- 50 mm (2 in) Height Adjustment
- For top belt heights below 600 mm (24 in)
- Support stands can be moved on 150mm increments depending on conveyor configuration

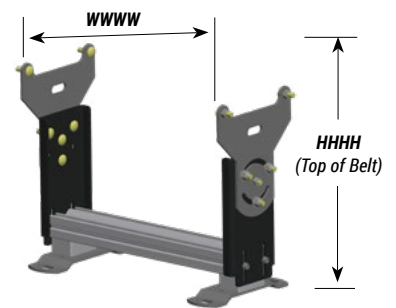

DCMove Material Handling Support Stands

3	S	Z	WWWW	-	HHHH	HHHH	B	S	T	T	F
- Feet or Casters: F = Fixed Foot Pad C = Total Lock Swivel Caster B = Fixed Foot with Brace (not available on shortest Low height stands) - Stand Type: LH = Short Stand FH = Fixed Height - Configuration: S = Straight - Belt: B = Belt - Maximum TOB: 0100 more than minimum - Minimum TOB: 0325 to 1900 in 25mm increments - Conveyor Width Reference: 152 mm to 1219 mm - Documentation Language: Z = Universal - Prefix: 3S = 32 MH (Steel) Mounting Packages											

Quantity Charts

DCMove Series	
Conveyor Length	Number of Supports
960 - 2,985mm (3 - 10ft)	2
2,986 - 5,970mm (10 - 20ft)	3
5,971 - 8,955mm (20 - 29ft)	4
8,956 - 11,940mm (29 - 39ft)	5
11,941 - 14,925mm (39 - 49ft)	6
14,926 - 17,910mm (49 - 59ft)	7
17,911 - 20,895mm (59 - 69ft)	8
20,896 - 23,880mm (69 - 78ft)	9
23,881 - 26,865mm (78 - 88ft)	10
26,866 - 29,850mm (88 - 98ft)	11

DCMove (per section) Required Return Roller					
max feet between return rollers					
Conveyor Width	10"	12"- 20"	22"- 30"	32"- 40"	40"- 48"
Flat Belt	8	7	6	5	4
Cleated Belt	6	5	4	3	3

Mounting Brackets

Stand Mounting Bracket



351518

Part Number	Description
351518	Table Top Bracket*

* for cleared belt application spacers maybe needed.

Photo Eye Bracket Kits

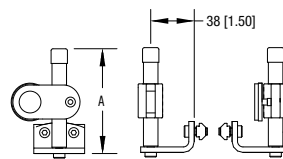

A = 92 [3.61] for 51 [2] Adjustment
168 [6.61] for 127 [5] Adjustment

Specifications

- Standard mounting for 18 mm barrel/nose mount photo-eyes
- Reflective version includes reflector
- Through beam mount version
- Fully adjustable mount for industrial conveyors

Part Number	Photo Eye Mount Type	Adjustment Height
75M-PM-1	Reflective	51 mm (2 in)
75M-PM-2	Reflective	127 mm (5 in)
75M-PM-3	Through Beam	51 mm (2 in)
75M-PM-4	Through Beam	127 mm (5 in)
75M-PM-5	Convergence	51 mm (2 in)
75M-PM-6	Convergence	127 mm (5 in)







Note: Dimensions = mm (in)

Due to the wide variety of drive set ups and applications, point of installation guarding is the responsibility of the end user.

Regulatory Approvals:

Gearmotors and Controllers:

All Dorner DCMove Series gearmotors and controllers carry one or more of the following approvals. Products are not covered by each approval. Please see the appropriate part number on the Gearmotor and controller charts located in this manual. In addition, regulatory symbols are located on the product information tags located on the product.

	<p>CE Marking on a product is a manufacturer's declaration that the product complies with the essential requirements of the relevant European health, safety and environmental protection legislation, in practice by the Product Directives. CE Marking on a product ensures the free movement of the product within the European Union (EU).</p>
	<p>This directive restricts (with exceptions) the use of six hazardous materials in the manufacture of various types of electronic and electrical equipment. It is closely linked with the Waste Electrical and Electronic Equipment Directive (WEEE) 2002/96/EC which sets collection, recycling and recovery targets for electrical goods and is part of a legislative initiative to solve the problem of huge amounts of toxic e-waste.</p>
	<p>The UL Recognized Component mark is for products intended to be installed in another device, system or end product. This Recognized Component Mark is for the United States only. When a complete product or system containing UL Recognized Components is evaluated, the end-product evaluation process can be streamlined.</p>
	<p>The UL Recognized Component mark is for products intended to be installed in another device, system or end product. This Recognized Component Mark is for the United States and Canada. When a complete product or system containing UL Recognized Components is evaluated, the end-product evaluation process can be streamlined.</p>
	<p>CSA International (Canadian Standards Association), is a provider of product testing and certification services for electrical, mechanical, plumbing, gas and a variety of other products. Recognized in the U.S., Canada and around the world, CSA certification marks indicate that a product, process or service has been tested to a Canadian or U.S. standard and it meets the requirements of an applicable CSA standard or another recognized document used as a basis for certification.</p>
	<p>The UL Listing Mark means UL found that representative product samples met UL's safety requirements. These requirements are primarily based on UL's own published standards for safety. The C-UL-US Mark indicates compliance with both Canadian and U.S. requirements. The products with this type of Mark have been evaluated to Canadian safety requirements and U.S. safety requirements.</p>

Belting:

The following is a list of the top coat materials used in DCMove Series conveyor belting:

Material	Belt Number
Urethane	01,02,03,05,06,09,54,55,56,53,60,61,63,68,69
PVC (non FDA approved)	08,18,59,64
Silicone	50
Polyester	66
Nitrile	57
Urethane (hard)	58

Resistance to Materials: Belting

The following table provides the resistance to belt materials used in the conveyor to several chemicals. Application testing is recommended to determine long term material durability.

Legend:

1 = Good resistance | 3 = Limited resistance | 4 = Not recommended

Materials	Urethane	PVC (non FDA)	Silicone	Polyester	Urethane (hard)
Chemicals					
Acetic acid (glacial acetic acid)	4	3	1	1	4
Acetic acid 10 %	3	1	1	3	1
Acetic anhydride	3	4	1	1	4
Acetone	4	4	1	3	4
Aluminium salts	1	1	1	1	1
Alum	1	1	1	1	1
Ammonia, aqueous	3	1	1	3	1
Ammonia, gaseous	1	1	3	1	1
Ammonium acetate	1	1	1	1	1
Ammonium carbonate	1	1	1	1	1
Ammonium chloride	1	1	1	1	1
Ammonium nitrate	1	1	1	1	1
Ammonium phosphate	1	1	1	1	1
Ammonium sulphate	1	1	1	1	1
Amyl alcohol	1	4	3	1	1
Aniline	3	3	3	4	4
Barium salts	1	1	1	1	1
Benzaldehyde	4	4	4	4	4
Benzine (see also Motor fuels)	1	3	3	1	1
Benzoic acid	1	1	1	1	1
Benzol	3	4	4	3	3
Boric acid	1	1	1	1	1
Boric acid, solution	1	1	1	1	1
Bromine	4	4	4	4	4
Bromine water	4	3	1	4	3
Butane, gaseous	1	1	1	1	1
Butane, liquid	1	1	1	1	1
Butyl acetate	4	4	4	3	4
n-Butyl alcohol	1	3	1	1	1
Calcium chloride	1	1	1	1	1

Resistance to Materials: Belting (continued)

Legend:
1 = Good resistance | 3 = Limited resistance | 4 = Not recommended

Materials	Urethane	PVC (non FDA)	Silicone	Polyester	Urethane (hard)
Calcium nitrate	1	1	1	1	1
Calcium sulphate	1	1	1	1	1
Carbon disulphide	4	4	3	4	4
Carbon tetrachloride	3	4	4	4	3
Chlorine, liquid	4	4	4	4	4
Chlorine, gaseous, dry	4	4	4	4	4
Chlorine, gaseous, wet	4	4	4	4	4
Chlorine water	4	1	3	4	3
Chlorobenzene	4	4	4	4	4
Chloroform	4	4	4	4	4
Chlorosulphonic acid	4	4	4	4	4
Chromic acid	4	4	4	4	4
Chromium salts	1	1	1	1	1
Chromium trioxide	1	1	1	1	1
Citric acid	4	1	1	1	4
Copper salts	1	1	1	1	3
Cresols	3	3	3	4	3
Cresols, aqueous	3	3	3	3	3
Cyclohexane	4	4	4	1	4
Cyclohexanol	4	4	4	4	4
Cyclohexanone	4	4	4	4	4
Decahydronaphthalene	4	4	4	4	4
Dibutyl phthalate	3	4	1	4	4
Diethyl ether	4	4	4	4	4
Dimethyl formamide	4	4	3	4	4
1.4 Dioxan	4	4	3	4	4
Ether	4	4	4	4	4
Ethyl acetate	4	4	4	3	4
Ethyl alcohol, non-denatured 100%	1	3	3	1	1
Ethyl alcohol, non-denatured 96%	1	3	3	1	1
Ethyl alcohol, non-denatured 50%	1	3	3	1	1
Ethyl alcohol, non-denatured 10%	1	3	1	1	1
Ethyl benzene	4	4	4	4	4
Ethyl chloride	4	4	4	4	4
Ethylene chloride	4	4	4	4	4
2-Ethyl hexanol	1	3	1	1	1
Formaldehyde	1	3	1	3	1
Formic acid, dilute	4	1	1	3	3
Glycerine	1	1	1	1	1
Glycerine, aqueous	1	1	1	1	1
Glycol	1	3	1	1	1
Glycol, aqueous	1	1	1	1	1
Heptane	1	3	3	1	1
Hexane	1	3	3	1	1
Hydrochloric acid, conc.	3	1	4	3	1

Resistance to Materials: Belting (continued)

Legend: 1 = Good resistance 3 = Limited resistance 4 = Not recommended					
Materials	Urethane	PVC (non FDA)	Silicone	Polyester	Urethane (hard)
Hydrochloric acid 10 %	3	1	1	1	1
Hydrofluoric acid 40 %	4	4	4	4	4
Hydrogen chloride, gaseous, dilute	3	1	3	3	1
Hydrogen chloride, gaseous, conc.	3	3	3	4	3
Hydrogen peroxide 10%	3	1	1	3	1
Hydrogen sulphide	3	3	3	3	3
Iron salts (sulphate)	1	1	1	1	1
Isooctane	1	3	3	1	1
Isopropyl alcohol	1	3	1	1	1
Lactic acid	1	3	1	1	1
Magnesium salts	1	1	1	1	1
Mercury	1	1	1	1	1
Mercury salts	1	1	1	1	1
Methyl alcohol, aqueous 50 %	3	3	1	1	1
Methyl alcohol (methanol)	1	3	1	1	1
Methyl ethyl ketone	4	4	1	3	4
Methylene chloride	4	4	4	4	4
Naphthalene	3	4	4	3	4
Nickel salts	1	1	1	1	1
Nitric acid	4	3	4	4	4
Nitrobenzene	4	4	1	3	4
Octane (see also isooctane)	1	3	4	1	1
Oleic acid	1	3	4	1	1
Oxalic acid	1	1	1	1	1
Ozone	1	3	3	1	3
Perchloroethylene	4	4	4	4	4
Phenol	3	3	1	4	3
Phenol, aqueous	4	3	1	4	3
Phosphoric acid 85 %	4	1	1	3	1
Phosphoric acid 50 %	1	1	1	1	1
Phosphoric acid 10 %	1	1	1	1	1
Phosphorus pentoxide	1	1	1	1	1
Potash lye 50 %	4	1	4	3	4
Potash lye 25 %	4	1	4	1	4
Potash lye 10 %	4	1	3	1	4
Potassium carbonate (potash)	1	1	1	1	1
Potassium chlorate	1	1	1	1	1
Potassium chloride	1	1	1	1	1
Potassium dichromate	1	1	1	1	1
Potassium iodide	1	1	1	1	1
Potassium nitrate	1	1	1	1	1
Potassium permanganate	1	1	1	1	1
Potassium persulphate	1	1	1	1	1
Potassium sulphate	1	1	1	1	1
Propane, gaseous	1	1	1	1	1

Resistance to Materials: Belting (continued)

Legend: 1 = Good resistance 3 = Limited resistance 4 = Not recommended					
Materials	Urethane	PVC (non FDA)	Silicone	Polyester	Urethane (hard)
Propane, liquid	1	1	1	1	1
Pyridine	4	4	3	4	4
Silver salts	1	1	1	1	1
Soda lye 50% (see potash lye)	4	1	4	4	4
Soda lye 25%	4	1	4	3	4
Soda lye 10%	4	1	3	1	4
Sodium bisulphite	1	1	1	1	1
Sodium carbonate (natron)	1	1	1	1	1
Sodium carbonate (soda)	1	1	1	1	1
Sodium chlorate	1	1	1	1	1
Sodium chloride (common salt)	1	1	1	1	1
Sodium hydroxide (caustic soda)	4	1	4	1	4
Sodium hypochlorite	1	1	1	3	1
Sodium nitrate	1	1	1	1	1
Sodium nitrite	1	1	1	1	1
Sodium perborate	1	1	1	1	1
Sodium phosphate	1	1	1	1	1
Sodium sulphate (Glauber salt)	1	1	1	1	1
Sodium sulphide	1	1	1	1	1
Sodium sulphite	1	1	1	1	1
Sodium thiosulphate (fixing salt)	1	1	1	1	1
Stearic acid	1	1	1	1	1
Succinic acid	1	1	1	1	1
Sulphur	1	1	1	1	1
Sulphur dioxide	3	3	3	3	4
Sulphuric acid 96%	4	4	4	4	4
Sulphuric acid 50%	4	3	4	3	4
Sulphuric acid 25%	4	3	3	1	3
Sulphuric acid 10%	4	3	1	1	3
Tartaric acids	1	1	1	1	1
Tetrachloroethane	4	4	4	4	4
Tetrachloroethylene (perchloroethylene)	4	4	4	4	4
Tetrahydrofuran	4	4	4	4	4
Tetrahydronaphthalene	4	4	4	4	4
Thiophene	4	4	4	4	4
Tin II chlorides	1	1	1	1	1
Toluene	4	4	4	4	4
Trichloroethylene	4	4	4	4	4
Urea, aqueous	1	1	1	1	1
Water	1	1	1	1	1
Xylene	4	4	4	3	4
Zinc salts	1	1	1	1	1

Resistance to Materials: Belting (continued)					
Legend: 1 = Good resistance 3 = Limited resistance 4 = Not recommended					
Materials	Urethane	PVC (non FDA)	Silicone	Polyester	Urethane (hard)
Products					
Alum	1	1	1	1	1
Anti-freeze*	1	3	1	1	1
Aqua regia	4	4	4	4	4
Asphalt	1	3	3	1	1
Battery acid	4	4	4	4	4
Benzine	1	3	3	1	1
Bleaching lye (12.5%)	1	1	1	1	3
Bone oil	1	3	4	1	1
Borax	1	1	1	1	1
Brake fluid* Bosch	1	3	1	1	3
Brake fluid* Skydrol	4	4	3	4	4
Chloride of lime (aqueous suspension)	1	1	1	1	3
Chlorine (active)	4	4	4	4	4
Chrome baths* (technical)	1	3	3	1	1
Chromosulphuric acid	4	4	4	4	4
Cresol solution	3	3	4	4	4
Diesel oil	1	1	3	1	1
Fertilizer salts	1	1	1	1	1
Fixing salt	1	1	1	1	1
Floor wax	1	3	3	1	1
Formalin	1	3	3	1	1
Fuel oils*	1	1	3	1	1
Furniture polish*	1	3	3	1	1
Gypsum	1	1	1	1	1
Ink*	1	1	1	1	1
Linseed oil	1	3	1	1	1
Litex (styrene)	4	4	4	4	4
Mineral oils (non-aromatic)	1	1	1	1	1
Moth balls	3	4	3	3	3
Diesel oil*	1	1	3	1	1
Petrol (gasoline) DIN51635	1	3	3	1	1
Petrol, regular	1	3	3	1	1
Petrol, super	3	4	3	1	3
Motor oils*	1	1	1	1	1
Oil no. 3 (ASTM)	1	3	1	1	1
Oleum	4	4	4	4	4
Paraffin	1	1	1	1	1
Paraffin oil	1	1	1	1	1
Petroleum	1	3	3	1	1
Petroleum ether	1	3	4	1	1
Photographic developer	1	1	1	1	1

Bearings and Lubrication:

All bearings on the DCMove Series conveyor are sealed and lubricated for life. No grease zerk is available and no greasing over the life of the product is required.

All gearmotors used on the DCMove Series conveyor are sealed and may be mounted in any position. Changing gear oil lubrication may be needed over the life of the gearbox. Please check the appropriate gearmotor manual for instructions.

Support Stand Locations:

Support Stand Locations		
Symbol	Description	Value mm (in)
A	Maximum distance back at drive end	619 (24)
B	Maximum distance back at idler end	821 (32)
C	Maximum distance between supports*	2,165 (85)

*Intermediate stands must be located on frame connection.

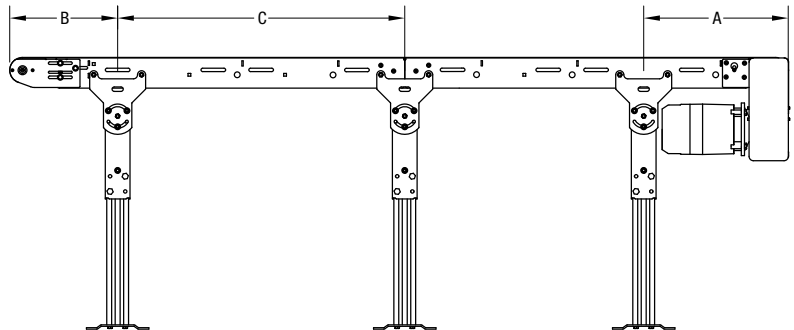

Conveyor Drive Shaft Tolerances:

End Drive:

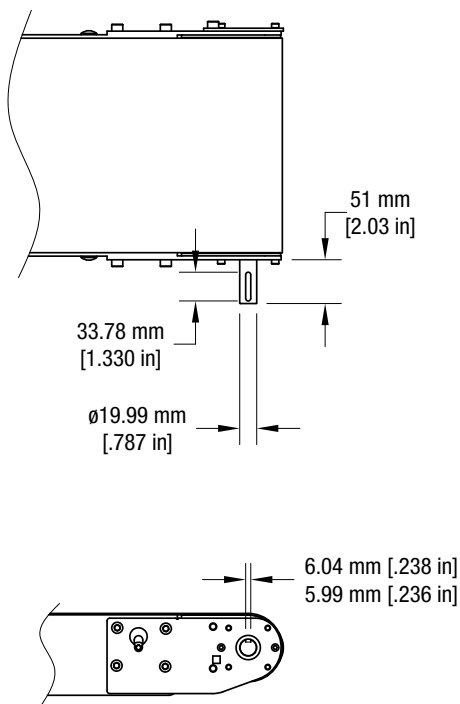

Center Drive:

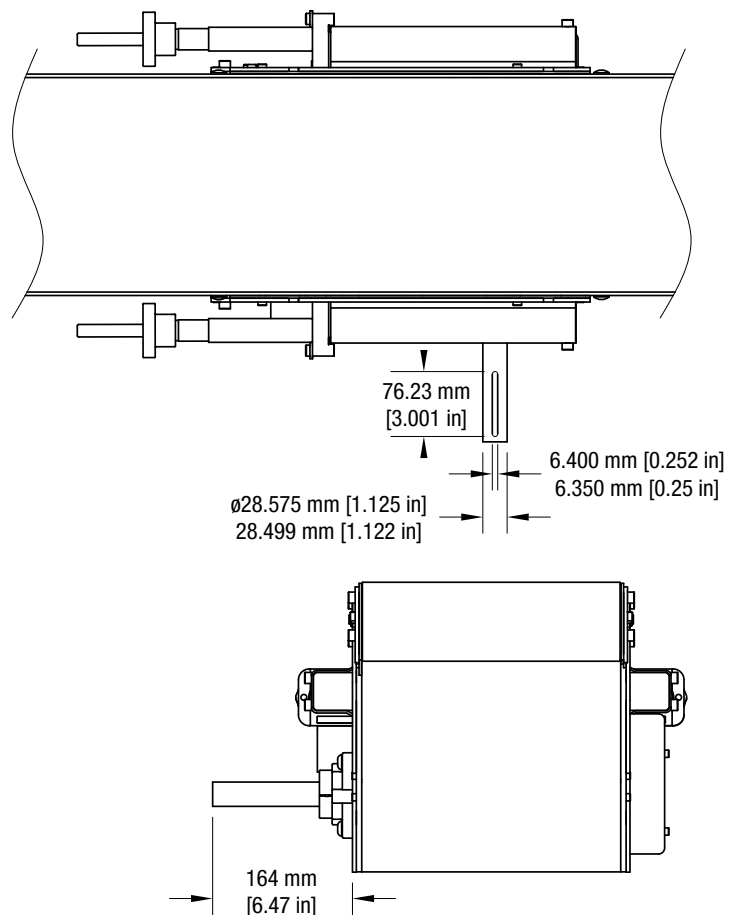

Conveyor Noise Level (Decibel Ratings)

The actual noise level generated by the conveyor depends on several factors; the installation configuration, the product running on the conveyor, the surrounding equipment, the conveyor options and belt speed. The noise level generated by the conveyor is typically less than the general noise level of factory equipment.

Generally a higher belt speed will result in a higher noise level. The following charts provide basic decibel ratings for a typical conveyor arrangements.

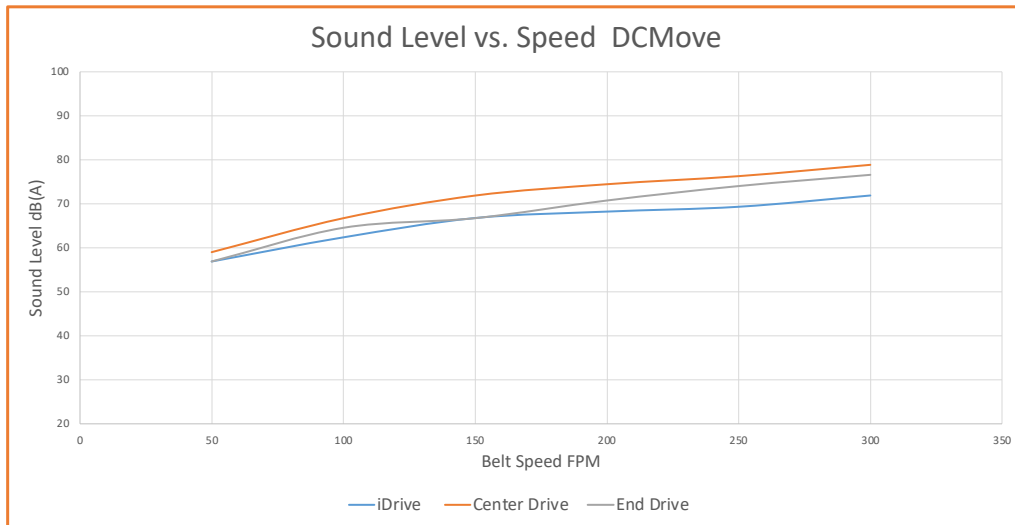

Maximum Load Capacity

The following Load Capacity Charts **do not** take into account the conveyor configuration, length or gearmotor selection. Your specific conveyor may not be capable of the maximum load condition. Please confirm your maximum load per application with the Dorner DTools program at www.dornerconveyors.com.

All load capacities shown are non-accumulated evenly distributed loads.

DCMove Series End Drive Belted Conveyor		
Belt Width	Direction 1, Pulling the Belt	Direction 2, Pushing the Belt
254 to 1219 mm (10 to 48 in) wide	181 kg (400 lbs)	60 kg (132 lbs)

DCMove Series Center Drive Belted Conveyor		
Belt Width	Direction 1, Pulling the Belt	Direction 2, Pushing the Belt
254 mm (10 in) wide	272 kg (600 lbs)	90 kg (198 lbs)
305, 356 and 406 mm (12, 14 and 16 in) wide	318 kg (700 lbs)	105 kg (231 lbs)
457, 508, 559 and 610 mm (18, 20, 22 and 24 in) wide	363 kg (800 lbs)	120 kg (264 lbs)
660 to 1219 mm (26 to 48 in) wide	454 kg (1000 lbs)	150 kg (330 lbs)

No Load Torque

No load torque is the amount of torque required to turn an empty conveyor. The torque value varies by conveyor length and configuration. The following charts provide basic values for an average length conveyor. Your specific conveyor may not have a higher value. Please confirm your no load torque and maximum load per application with the Dorner DTools program at www.dornerconveyors.com.

Belted Conveyor No Load Torque		
Belt Width mm (in)	End Drive mm-kg (in-lbs)	Center Drive m-kb (in-lbs)
254 (10)	728 (13)	7840 (140)
305 (12)	840 (15)	8400 (150)
356 (14)	1120 (20)	8680 (155)
406 (16)	1120 (20)	8680 (155)
203 (18)	1400 (25)	8960 (160)
508 (20)	1512 (27)	9240 (165)
559 (22)	1512 (27)	9520 (170)
610 (24)	1680 (30)	10080 (180)
660 (26)	1848 (33)	10640 (190)
711 (28)	1848 (33)	10640 (190)
762 (30)	1960 (35)	11200 (200)
813 (32)	2128 (38)	11760 (210)
864 (34)	2128 (38)	11760 (210)
914 (36)	2128 (38)	12320 (220)
965 (38)	2240 (40)	12600 (225)
1016 (40)	2240 (40)	12880 (230)
1067 (42)	2240 (40)	12880 (230)
1118 (44)	2240 (40)	13160 (235)
1168 (46)	2240 (40)	13440 (240)
1219 (48)	2240 (40)	13440 (240)

Belting and Coefficient of Friction

The coefficient of friction is used to determine the load a conveyor can carry. It affects a conveyor in two ways: the friction that exists between the conveyor belt and the bed surface, and if accumulating product the friction that exists between the conveyor top surface and the product.

Coefficient of Friction, between the bottom of the conveyor belt and bed surface			
Product	Surfaces	Application Condition	Coefficient of Friction
DCMove Series Belted	Impregnated polyester fabric to Painted Steel bed plate	Dry	0.23

Coefficient of Friction, between the top surface of conveyor belt and product:

DCMove Series Belted		
The following table provides the coefficient of friction between steel product and various belt top surfaces. All factors below are assuming dry conditions.		
Belt Number	Top Surface Material and Type	Coefficient of Friction
01, 54, 58, 68	Smooth hard urethane	0.40
02, 59, 60, 61, 66	Smooth medium urethane	0.50
03, 19, 55, 69	Glossy soft urethane	>1.0, do not accumulate
05, 06, 50, 53, 63	Impregnated polyester fabric	0.20
08, 18, 64	PVC, Very High friction	>1.0, do not accumulate

Calculating Conveyor Belt Speed

DCMove Series Belted Conveyors:

To calculate the conveyor belt speed you need to know the following factors:

- Drive roller diameter
 - 76.2 mm (3 in) for end drives
 - 1152.4 mm (6 in) for center drives
- Number of teeth of pulley located at drive roller (if equipped)
- Number of teeth of pulley located at gearmotor (if equipped)
- RPM of gearmotor

$$\text{Belt Speed (ft/min)} = (\text{Drive roller diameter}/12) * (3.14) * (\text{RPM of gearmotor}) * \frac{(\text{Teeth at gearmotor})}{(\text{Teeth at drive roller})}$$

Example:

DCMove Series End Drive with a Bottom mount with a 16 tooth pulley located at the drive roller and a 24 tooth pulley located on the gearmotor. The gearmotor is a 10:1 ratio with 173 rpm output.

$$\text{Belt Speed (ft/min)} = (3/12) * (3.14) * (173) * (24/16)$$

$$\text{Belt speed (ft/min)} = 204 \text{ ft/min}$$

Calculating Conveyor Load Capacity

There are several factors that affect the overall conveyor load of the DCMove Series conveyor. These include:

- Conveyor size and configuration
- Conveyor speed
- Application temperature
- Product accumulation
- Number of starts and stops per hour

Located online at www.dornerconveyors.com is the Dorner conveyor configuration tool, DTools. This tool allows you to configure your conveyor layout and determine the maximum load capacity for the conveyor. It is suggested that this program be used to calculate the conveyor load as the calculation is quite complicated. This configuration program however does not take into account temperature, dirty conditions, and conveyor starts and stops. If these conditions are part of your application please use the load reducing factors as shown below.

$$\text{Maximum Load} = (\text{Load from DTools})(\text{Temperature Factor})(\text{Start/Stop Factor})$$

Temperature Factor		
Ambient temperature can negatively affect the capacity of the conveyor.		
Temperature F	Temperature C	Temperature Factor
-4	-20	1.0
32	0	1.0
68	20	1.0
104	40	0.9
140	60	0.8

Start / Stop Factor	
Frequent Start / Stops of the conveyor can negatively affect the capacity of the conveyor. All start / stop applications must use a soft start mechanism such as a Frequency Inverter with a 1 second acceleration cycle.	
Application Condition	Start / Stop Factor
Continuous Run or 1 start/stop per hour	1.0
Maximum 10 starts/stop per hour	0.83
Maximum 30 starts/stop per hour	0.70
Greater than 30 starts/stop per hour	0.62



Industrial



Flexible Chain



Pallet Systems



Sanitary Stainless Steel

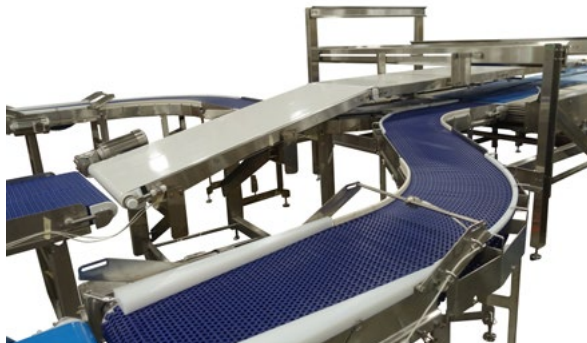

Engineered Solutions Group

Custom engineered solutions for almost any application.



CAD Configurator Tool

Industry leading tool! Configure your own custom conveyor in minutes.

TRANSFORMING CONVEYOR AUTOMATION

Contact Dorner

United States
+1-262-367-7600

Canada
+1-289-208-7306

Mexico
+52.33.30037400

Germany
+49 (0) 2461/93767-0

France
+33 (0)1 84 73 24 27

Malaysia
+604-626-2948



By Columbus McKinnon

DORNERCONVEYORS.COM



MAGNETEK

montrate2

CONVEYANCE SOLUTIONS

© Dorner Mfg. Corp. 2025. All Rights Reserved.

851-983 0125