

ENGINEERING MANUAL

Complex Configurations
& Tight Spaces

High Speed Performance
- Up to 76 mpm

Reduces
Conveyor Footprint

Ideal for Curves,
Inclines & Declines

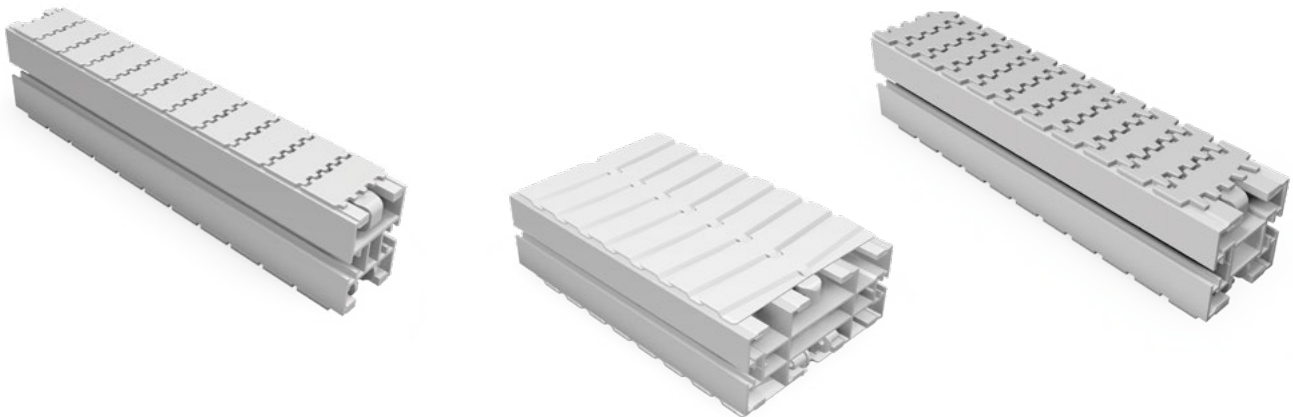
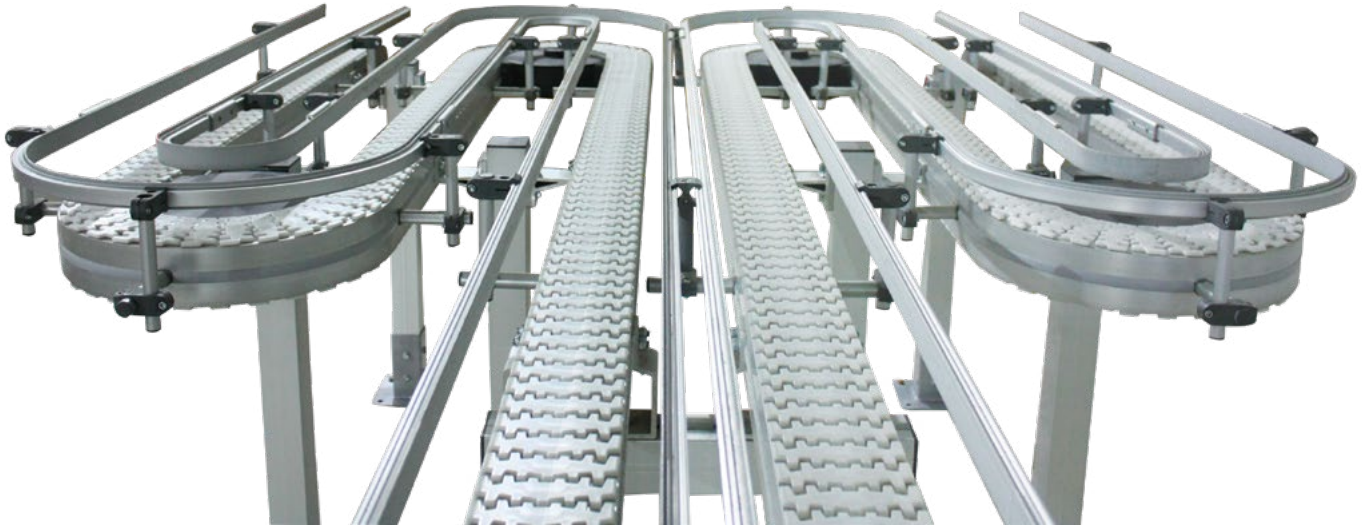

FlexMove®

High Performance, Aluminum,
Flexible Chain Conveyors

DORNER®
By Columbus McKinnon

TRANSFERS

FOR SMOOTH IN-LINE
TRANSFER OF PRODUCT

WHEEL CORNERS

ELIMINATE CORNER FRICTION ALLOWING
MULTIPLE CORNER CONFIGURATIONS

VERTICAL BENDS

FOR SMOOTH ELEVATION
CHANGES AND EFFICIENT
USE OF VERTICAL SPACE



T-SLOT FRAMEWORK

FOR EASE OF MOUNTING
ACCESSORIES

SUPPORT POST

PROVIDE ADJUSTABLE
HEIGHT WHILE OPTIMIZING
THE USE OF FLOOR SPACE

MODULAR FRAMING

FOR FUTURE ADD ON
CAPABILITY AND
PRODUCTION LINE CHANGES

Purchasing a FlexMove Conveyor

Dorner offers two solutions for purchasing a FlexMove Conveyor.

- The first solution is to order all the necessary parts and components to build your FlexMove Conveyor on site. This will require the proper tools for cutting, bending and installing the conveyor. Consult our installation guide for FlexMove Conveyors for more details.
- The second solution is to have a complete conveyor provided through our FlexMove Solutions. With FlexMove Solutions, you can have the conveyor built in our facility, tested, broken down into shippable sections and shipped to the end site for installation.

The contents of this publication are the copyright of the publishers and may not be reproduced (even extracts) unless permission is granted. Every care has been taken to ensure the accuracy of the information but no liability can be accepted for any errors or omissions.

The right is reserved to make design modifications

Patents

Essential parts of the FlexMove product range are protected by patents and design regulations.

Drawings are made to European standards.

June 2024

Product Overview & Introduction	4 – 9
FK 45mm Conveyor System	10 – 25
FS 65mm Conveyor System	26 – 48
FM 85mm Conveyor System	49 – 72
FC 105mm Conveyor System.....	73 – 94
FL 150 mm Conveyor System	95 – 111
FU 180 mm Conveyor System	112 – 124
FV 260 mm Conveyor System	125 – 137
FZ Function Modules.....	136 – 149
FA Conveyor Accessories	150 – 163
FB Conveyor Support Options.....	164 – 172
FB Conveyor Support Components.....	173 – 180
FG Conveyor Guide Options.....	181 – 200
FG Conveyor Guide Components	201 – 219
Gearmotors	220 – 224
Controllers	225 – 226
Pallet Systems	227 – 230
Technical Data & Calculations	231 – 242

Dorner reserves the right to make alteration without prior notification. Every care has been taken to ensure the accuracy of the information contained in this Catalog but no liability can be accepted for any error or omissions.



Basic System Selection

We provide a wide selection of chain sizes to cover a wide variety of product sizes and shapes. In order to select the right chain size to use in your application, consider the following selection criteria:

- **Product Dimensions**

A product can be two or three times wider than the conveyor chain as long as the center of gravity of the product falls within the chain width. Extra supporting guide rails are required and testing is recommended.

- **Product Weight**

Product weight is important in chain selection as each chain has its maximum traction force. Traction force calculation is required when there are several heavy products to be conveyed, and it will increase further if the products are accumulated on the conveyor.

- **Conveyor Functions Available**

Most of the conveyor functions are available in all conveyor series, however there are differences with regards to the chain types, drive unit and idler unit variants. Selection of drive type is important as different drives have different traction forces.

- **Technical Calculation**

It is important to calculate total load on conveyor based on product weight, distance between products, accumulation and length of the system. The frequency of start /stop, chain tension and service factor are important. If the calculated capacity is higher than the selected drive and chain series, the conveyor should be shortened or select a system with higher capacity.

- **Small Footprint**

Straightforward layout and compact design maximizes valuable floor space while minimizing noise, maintenance and footprint.

- **Intermediate Drive Unit**

An intermediate drive is best utilized when space restriction prohibits the placement of the end drive unit. It requires idler end units at each end. The gearmotor can be coupled directly or suspended underneath the drive unit at both right and left orientation. Adjustable torque limiter can be added to protect the conveyor system. The traction force is lower than end drive units due to less engagement between drive sprocket and chain.

- **Catenary Drive Unit**

Catenary Drives are designed to accommodate top-running chains and are commonly used in application of single loop or alpine conveyor system. Additional idler end unit is not required. Only suspended version is available.

Basic System Selection *continued*

- **Combined Drive and Idler Unit**

A combined drive and idler consist of one end drive and one idler end unit mounted in a single assembly with a transfer bridge for smooth transfer of products. It has a smaller footprint compared to side transfer design. Available in both direct and suspended drive versions, the gear motor can be coupled at both left and right orientation. Adjustable torque limiter can be added to protect the conveyor system.

- **Wheel Drive Unit**

Wheel drives are used for applications using single loop or alpine conveyor system without return chain. Both direct and suspended drive versions are available with the gearmotor mounted underneath. The traction force is lower than other end drive units as the gear wheel engages the side of the chain.

- **Weight Take-Up**

To eliminate catenary sag, FlexMove conveyors come with a weighted take-up module.

The weighted take-up module automatically adjusts for chain stretch. The module provides smoother and quieter chain running and can also be positioned in various locations along the conveyor.

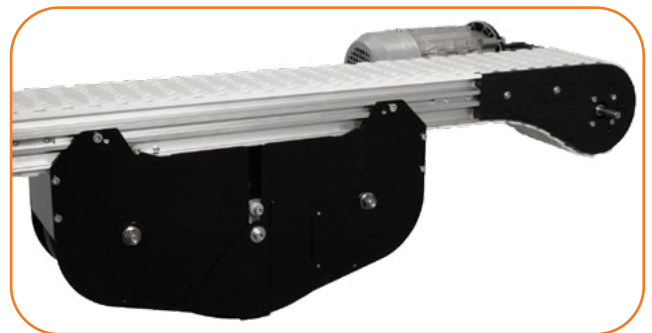

Idler End Unit

The function of the idler end is to change the direction of the moving chain. Available in both standard idler end unit (180°) and idler bend unit (90°). It comes with 2pc connecting strips at the connection end.

- **Idler End Unit (standard 180°)**

The moving chain is transferred 180° from the bottom of the conveyor beam to the top through a flange guide with minimal friction.

- **Idler Bend Unit (90°)**

The idler bend unit converts and changes the chain direction in 90° perpendicular to incoming chain direction.

Bends

Bends are used to change the direction of chain movement in conveyors. There are 3 types of bends available:

- **Wheel bends**

Designed with top and bottom wheels that rotate freely with the chain and are supported by a dual sealed ball bearing, providing the lowest friction, minimum bend force and smallest turning radius compared to other types of bends. Besides standard 30°, 45°, 60°, 90° and 180° configurations, special angles are also available upon request. Select a horizontal wheel bend whenever possible.

- **Horizontal Bends**

An alternative to wheel bends, horizontal bends are useful in conditions requiring large space, long products with large turning radius and twin – track bend applications. It has higher friction compared to wheel bends. Larger radius is recommended for lower friction and less stress on slide rail.

- **Vertical Bends**

A vertical bend provides vertical change of the conveyors moving direction. It can be used either as a convex or concave bend. Vertical bends increase the chain tension and cause higher stress on the slide rail. Avoid using more than four 90° vertical bends in one conveyor.

ALPINE CONVEYORS



The Alpine Conveyor is a compact spiral configuration commonly used as an accumulation or buffer zone in between machines or as a process step for cooling or drying. It is also used for line balancing and for repair and maintenance purposes.

It can be configured as an elevating/lowering system with a single or double serpentine configuration and used as an in-line accumulator with entry and exit at different levels, or an in-line or off-line accumulator with entry and exit at the same level.

The Alpine conveyor maximizes vertical space and ensures the efficient utilization of machines with different speeds and provides storage for pucks.

WEDGE CONVEYORS



Our wedge conveyors are used to take products from production floor level to a higher level or vice versa. Products are wedged between opposing conveyors lined vertically or horizontally and are moved swiftly but securely.

Wedge Conveyors are easy to construct, lightweight and have compact footprints. Its rapid transfer rate makes it ideal for use in continuous, high capacity operations such as packaging lines. Built with Aluminum and stainless steel, it meets the stringent hygiene standard required for medical and cosmetic packaging.

Wedge Conveyors can be configured differently for a variety of uses, such as a transition between different travel orientations, de-pucking operations, inverted rinse operations and even for creating a passage way on the production floor.

Wedge Conveyors are not suitable for wet products, heavy products or products that cannot withstand side pressure.



C-Wedge

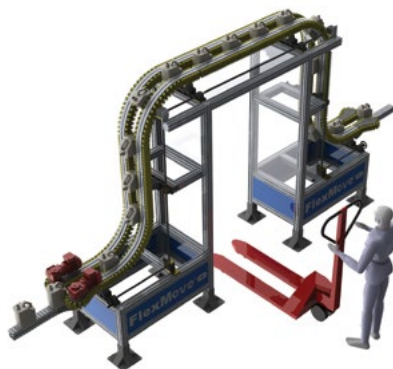

N-Wedge



S-Wedge

TWIST CONVEYORS



- Positively control the product during rotation
- Provides product rotation for access to multiple sides of packages
- No change over –can handle multiple package sizes at the same time
- No product guiding required
- Products do not need to be gapped or spaced
- Available Widths: 65, 85, 105 and 180 mm (2.5, 3, 4 and 7 in)
- Requires 2 independent FlexMove conveyors
- Helical twists up to 90 degrees per conveyor pair
- 90 degree twist is approximately 3 m (10 ft) long
- Speeds Up to 55 mpm (180 fpm)

HELIX CONVEYORS



- Unique, flexible design provides greater flexibility in layout
 - Infeed and outfeed may be positioned at any height or angle
 - Custom infeed and outfeed lengths allow the conveyor to extend beyond spiral, reducing the number of conveyors required
- Small foot print maximizes valuable floor space
- Patented side roller chain reduces corner friction allowing for faster speeds and smooth product handling
- Applications include accumulation, buffering, cooling product between processes or machines, and more
- Available in 85, 180 and 260 mm

HELICAL CURVE CONVEYORS



- Reduces conveyor footprint saving valuable floor space
- Allows incline or decline through corners and straights
- Patented side roller chain reduces corner friction
- Provides capability for product accumulation in the corners
- Simple, low cost spiral for small parts handling
- Available in 85, 180 and 260 mm

TOP RUNNING LOOP CONVEYORS



- Top running module create a continuous loop of conveyance
- Used for pallet systems, puck handling, and small manufacturing cells
- Conveyor chain runs on the top side of the frame only
- Available with top running drive module or wheel corner drives

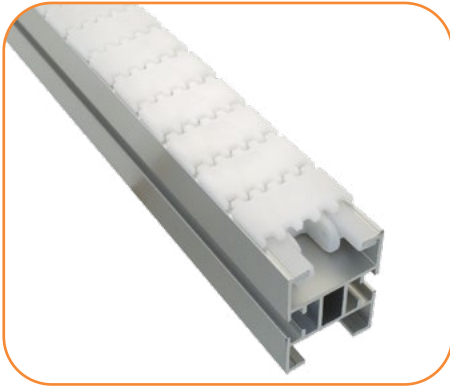

45 mm (1.7 in)

- Maximum load = 30 kg/m (20 lbs/ft)
- Maximum total load = 136 kg (300 lbs) non-accumulated
- Maximum length = 30 m (98 ft)
- Maximum Speed = 50 mpm (165 fpm)

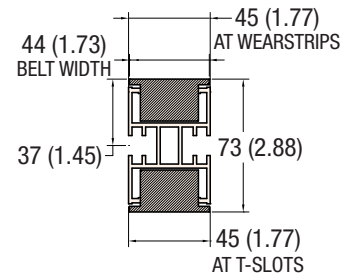

45 MM WIDTH



65 mm (2.5 in)

- Maximum load = 30 kg/m (20 lbs/ft)
- Maximum total load = 136 kg (300 lbs) non-accumulated
- Maximum length = 30 m (98 ft)
- Maximum Speed = 58 mpm (190 fpm)

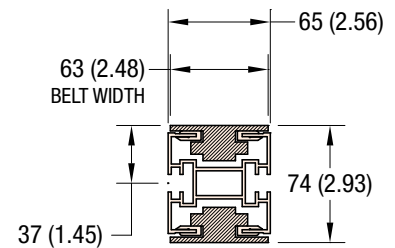

65 MM WIDTH



85 mm (3.4 in)

- Maximum load = 60 kg/m (40 lbs/ft)
- Maximum total load = 272 kg (600 lbs) non-accumulated
- Maximum length = 30 m (98 ft)
- Maximum Speed = 58 mpm (190 fpm)

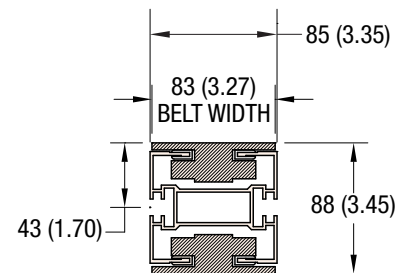

85 MM WIDTH



105 mm (4.1 in)

- Maximum load = 60 kg/m (40 lbs/ft)
- Maximum total load = 272 kg (600 lbs) non-accumulated
- Maximum length = 30 m (98 ft)
- Maximum Speed = 58 mpm (190 fpm)

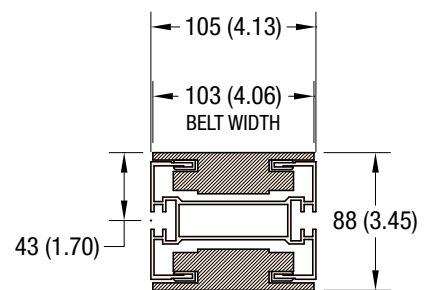

105 MM WIDTH

Note: Conveyor modules may be made up of several length of conveyor beam. Maximum length piece beam is 3,000 mm (118 in).

Note: Dimensions = mm (in)



150 mm (5.9 in)

- Maximum load = 60 kg/m (40 lbs/ft)
- Maximum total load = 272 kg (600 lbs) non-accumulated
- Maximum length = 30 m (98 ft)
- Maximum Speed = 58 mpm (190 fpm)

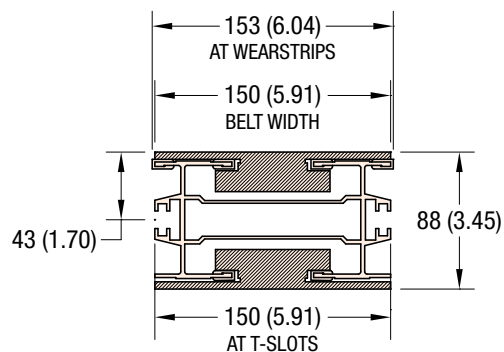

150 MM WIDTH



180 mm (7.1 in)

- Maximum load = 65 kg/m (44 lbs/ft)
- Maximum total load = 272 kg (600 lbs) non-accumulated
- Maximum length = 30 m (98 ft)
- Maximum Speed = 58 mpm (190 fpm)

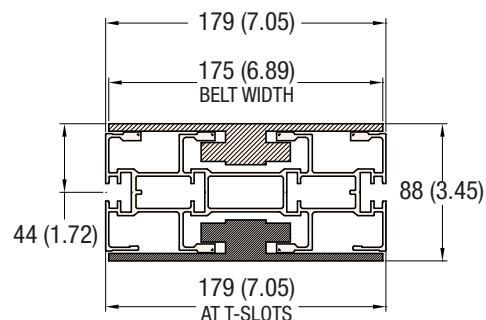

180 MM WIDTH

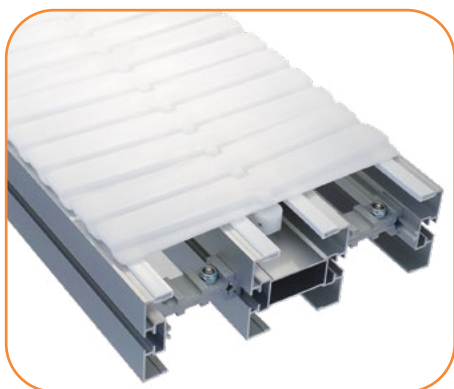

260 mm (10.2 in)

- Maximum load = 65 kg/m (44 lbs/ft)
- Maximum total load = 272 kg (600 lbs) non-accumulated
- Maximum length = 30 m (98 ft)
- Maximum Speed = 58 mpm (190 fpm)

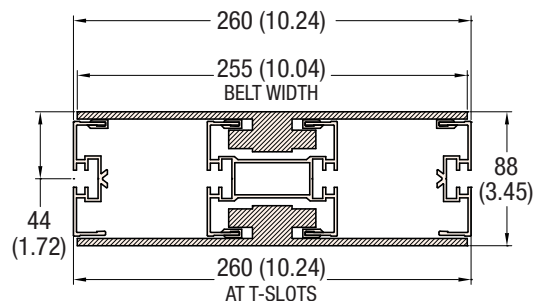

260 MM WIDTH

Note: Conveyor modules may be made up of several length of conveyor beam. Maximum length piece beam is 3,000 mm (118 in).

Note: Dimensions = mm (in)

FK Series is a compact and neat design for small items and fast transportation. It is also used for twin track application for pallet assembly lines.

FK Series Characteristic

Beam Width: 45 mm

Product Width: Refer to Guide Rail Assembly

Accessories Needed

Slide Rail Required: FASR-25K OR FASR-25KU

Slide Rail Color: White or Natural Color

Slide Rail Material: HDPE OR UHMW-PE

Slide Rail Rivet: FASLS-M3

Connecting strip is used to connect two beams.

Connecting Strip: FACS-20x140

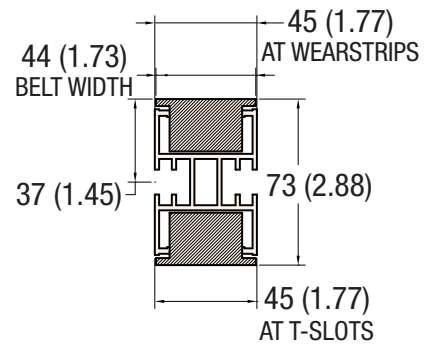

45 MM WIDTH

Conveyor Beam FKCB-3

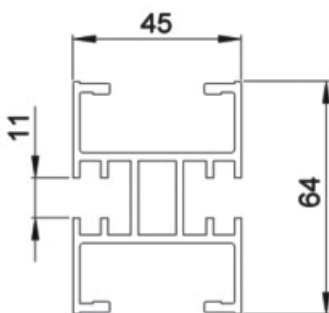

UOM: 3 Meter / Length

Conveyor Half Beam FKCB-3H

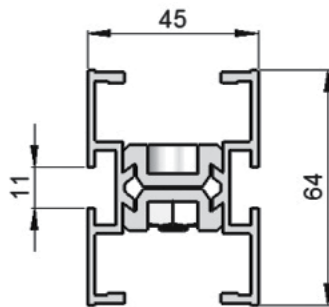

UOM: 3 Meter / Length

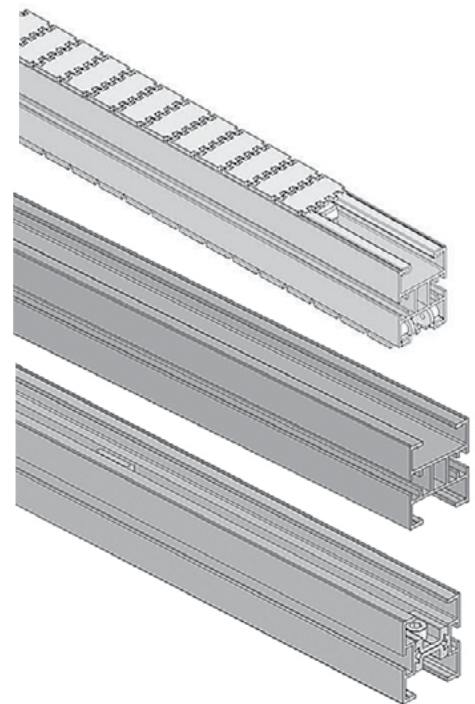

Chain Connecting Module FKCC-160

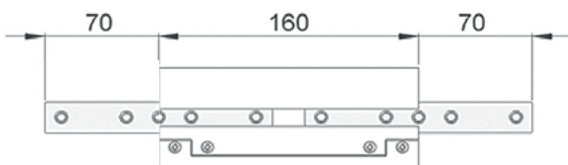

UOM: pc

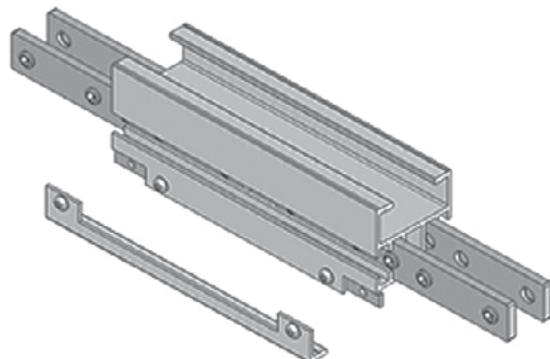

Chain Common Data

Packaging: 5 m per box

Pitch: 25.4 mm

Width: 44 mm

Tensile Strength at 20° C: 4000N

Color: White & Black (Conductive)

Material:

Chain: White Acetal / POM

Pivot: Polyamide

Pivot Pin: Stainless Steel

Insert (Wedge & Friction): TPE Grey

Standard Plain Chain **FKPC-5**

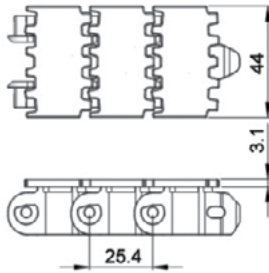
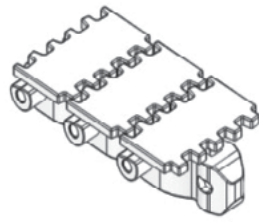

UOM: 5 Meter / box

Application: Suitable for horizontal and slope < 5° transport of products with accumulation.

Conductive Chain **FKPC-5CD**

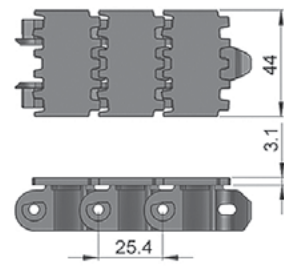
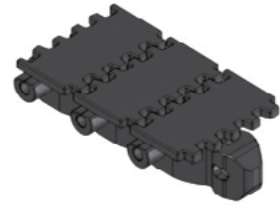

UOM: 5 Meter / box

Application: Suitable for transport of static sensitive product.

Wedge Top Chain Right **FKWT-5PR**

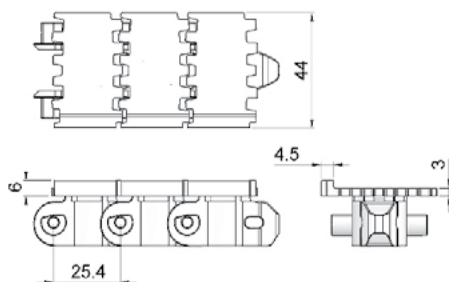
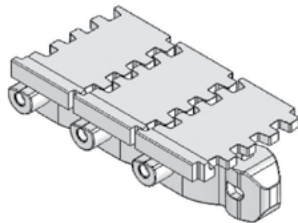

UOM: 5 Meter / box

Application: Suitable for PET bottle transport.

Wedge Top Chain Left **FKWT-5PL**

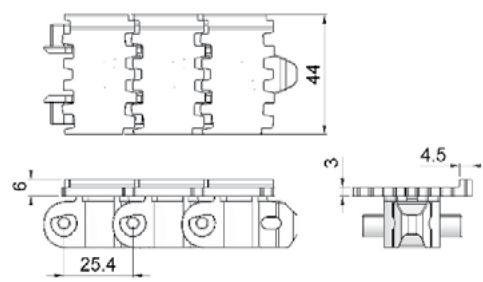
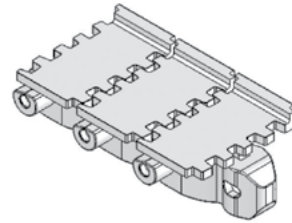

UOM: 5 Meter / box

Application: Suitable for PET bottle transport.

Friction Top Chain **FKFT-5**

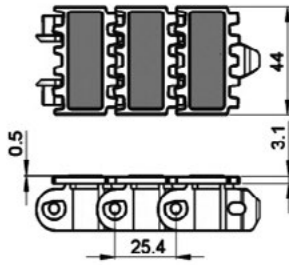
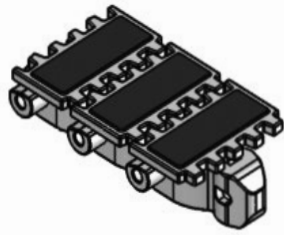

UOM: 5 Meter / box

Application: Suitable for transport product in slope $> 5^\circ$ but $\leq 30^\circ$ without accumulation.

Wedge Top Chain **FKWT-5C**

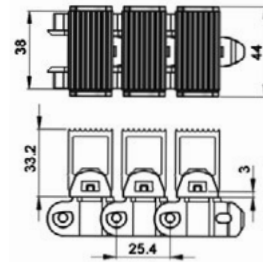
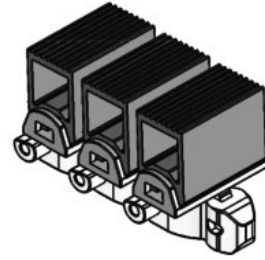

UOM: 5 Meter / box

Application: Vertical Wedge transportation of products.

Wedge Top Chain **FKWT-5D**

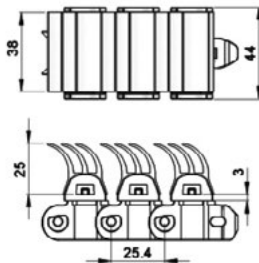
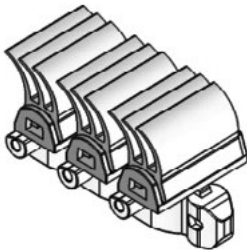

UOM: 5 Meter / box

Application: Vertical Wedge transportation of products.

Flocked Chain **FKFK-5**

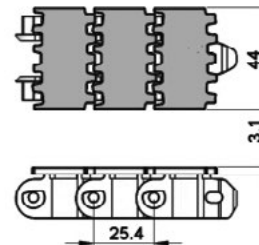
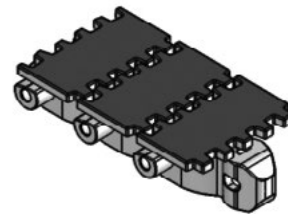

UOM: 5 Meter / box

Application: Suitable to transport lightweight, fragile and scratch sensitive product.

FK Direct End Drive without Motor (LEFT)

FKDD-A45-XDY (See Chart)

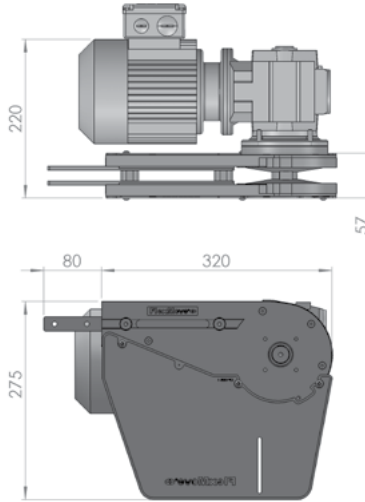
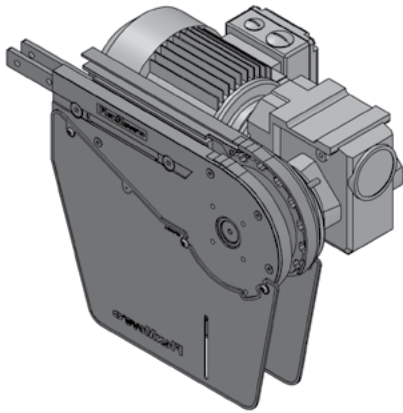

FK Direct End Drive without Motor (RIGHT)

FKDD-A45-XDY (See Chart)

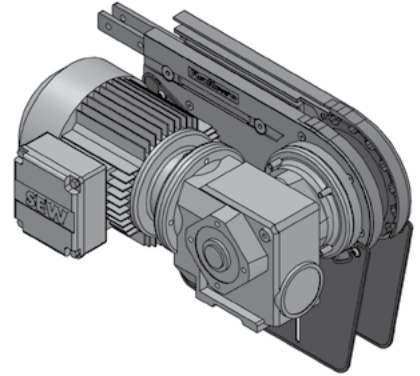

Note: Drive Module is 12 mm wider than conveyor frame.

Part Number		Shaft Selection	Direction	Aux Shaft Selection
FKDD-A45	-	X	D	Y
		0 = 20 mm	L = Left	Blank = No Aux Shaft
		E = 3/4 in*	R = Right	A = 20 mm Aux Shaft
		A = 20 mm Aux Only		

Max Traction Force: 500N

The Direct End Drive Unit is without torque limiter.

UOM: pc

Chain required 2-way: 0.8 meter
Slide rail required 2-way: 0.5 meter

*3/4 inch shaft option available in North America only.

FK Direct End Drive without Motor GP (LEFT)

FKDD-A45GP-XDY (See Chart)

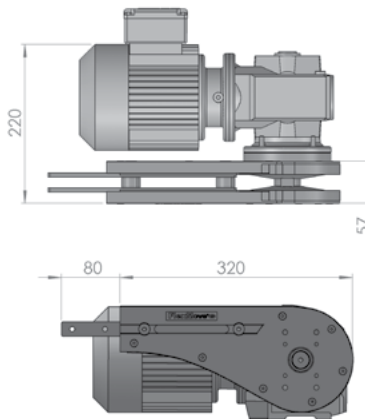
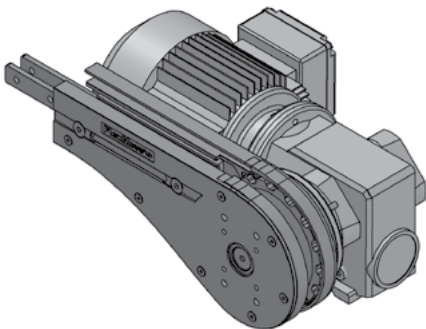

FK Direct End Drive without Motor GP (RIGHT)

FKDD-A45GP-XDY (See Chart)

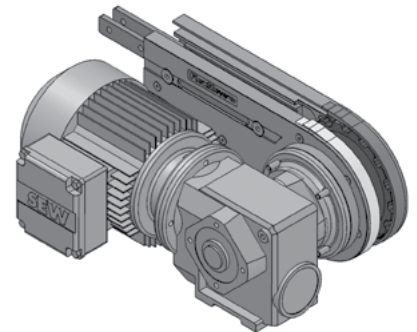

Note: Drive Module is 12 mm wider than conveyor frame.

Part Number		Shaft Selection	Direction	Aux Shaft Selection
FKDD-A45GP	-	X	D	Y
		0 = 20 mm	L = Left	Blank = No Aux Shaft
		E = 3/4 in*	R = Right	A = 20 mm Aux Shaft
		A = 20 mm Aux Only		

Max Traction Force: 500N

The Direct End Drive Unit GP is without torque limiter.

UOM: pc

Chain required 2-way: 0.55 meter
Slide rail required 2-way: 0 meter

*3/4 inch shaft option available in North America only.

SEW gearmotors are products of SEW Eurodrive

FK Direct Drive Driven Transfer Bridge (LEFT)

FKDD-A45DB-A-0L

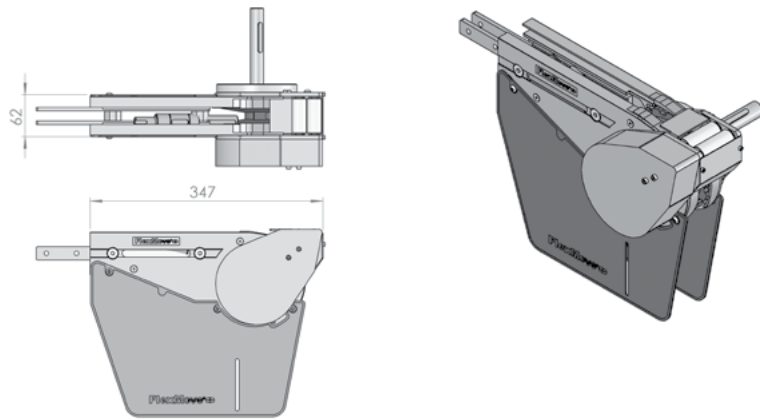

Note: Drive Module is 12 mm wider than conveyor frame.

FK Direct Drive Driven Transfer Bridge (RIGHT)

FKDD-A45DB-A-0R

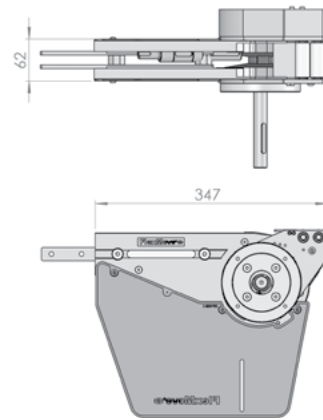

Max Traction Force: 500N

The Direct End Drive Unit is without torque limiter.

UOM: pc

Chain required 2-way: 0.55 meter
Slide rail required 2-way: 0 meter

FK Direct Drive Free Roller Transfer Bridge (LEFT/ RIGHT)

FKTB-A45

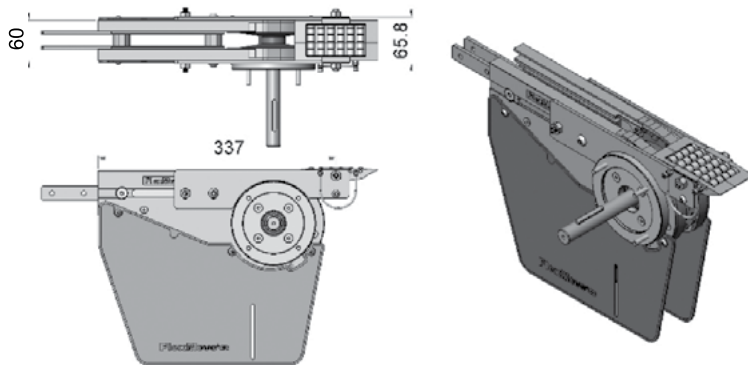

Transfer bridge c/w roller for FSIE-A 45
Transfer bridge c/w roller for FSDD-A 45-0L
Transfer bridge c/w roller for FSDD-A45-0R

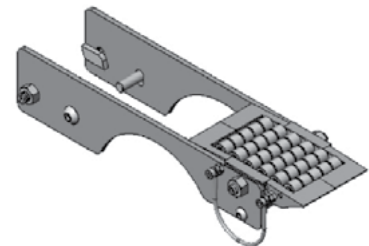

UOM: pc

FK Suspended End Drive without Motor (LEFT)

FKSD-A45-0L (with Torque Limiter)
FKSD-A45SPT-0L (without Torque Limiter)

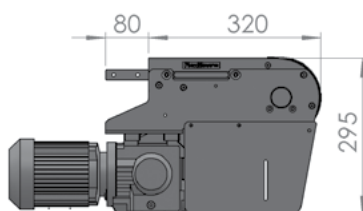
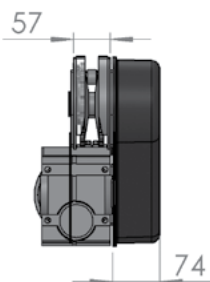
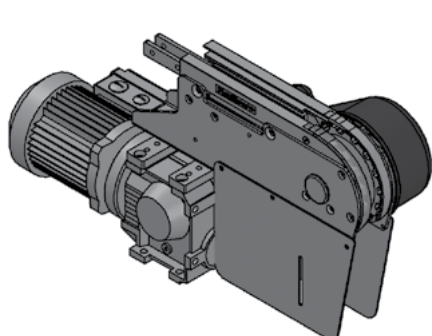

20 mm Shaft only.
Minimum product length for inline transfer = 100 mm
Transfer extends past conveyor only 27 mm

Note: Drive Module is 12 mm wider than conveyor frame.

FK Suspended End Drive without Motor (RIGHT)

FKSD-A45-0R (with Torque Limiter)
FKSD-A45SPT-0R (without Torque Limiter)

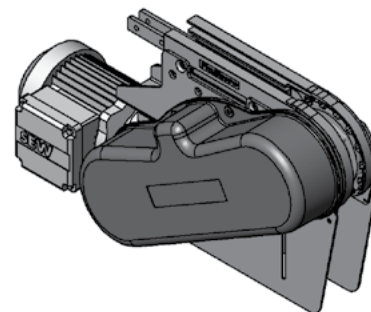

Max Traction Force: 500N

The Suspended End Drive Unit is available with or without torque limiter.

UOM: pc

Chain required 2-way: 0.8 meter
Slide rail required 2-way: 0.5 meter

FK Suspended Intermediate Drive without Motor (LEFT)

FKID-SD-0L1

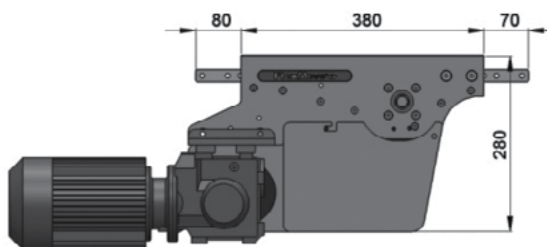
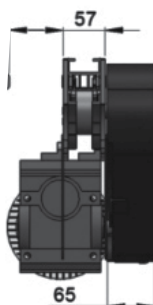
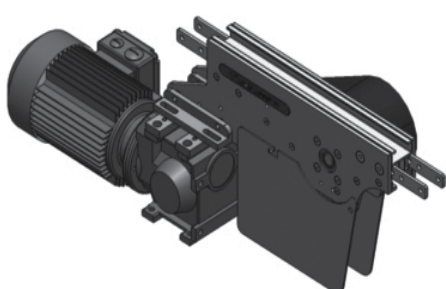

- Located in middle of conveyor to free up drive end.
- Includes torque limiter protecting chain and motor from overload
- Limits chain pull capacity to 200N

Note: Drive Module is 12 mm wider than conveyor frame.

FK Suspended Intermediate Drive without Motor (RIGHT)

FKID-SD-0R1



Max Traction Force: 200N

The Suspended Intermediate Drive Unit is with torque limiter.

UOM: pc

Chain required 2-way: 1.2 meter
Slide rail required 2-way: 1.1 meter

SEW gearmotors are products of SEW Eurodrive

FK Direct Intermediate Drive without Motor (LEFT)

FKID-DD-0L1

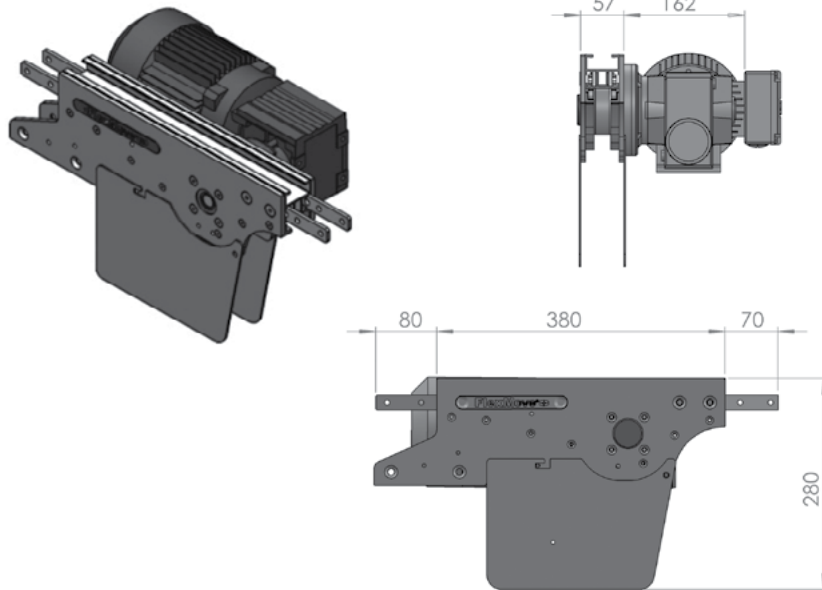

- Located in middle of conveyor to free up drive end.
- Includes torque limiter protecting chain and motor from overload
- Limits chain pull capacity to 200N

Note: Drive Module is 12 mm wider than conveyor frame.

FK Direct Intermediate Drive without Motor (RIGHT)

FKID-0R1

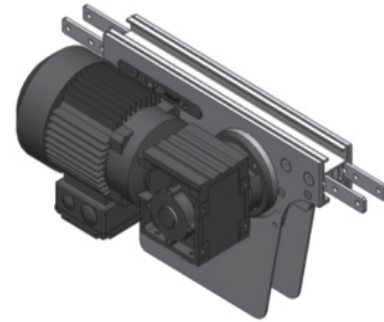

Max Traction Force: 200N

The Direct Intermediate Drive Unit is without torque limiter.

UOM: pc

Chain required 2-way: 1.2 meter
Slide rail required 2-way: 1.1 meter

FK Suspended Catenary Drive without Motor (LEFT)

FKCD-SD-0L

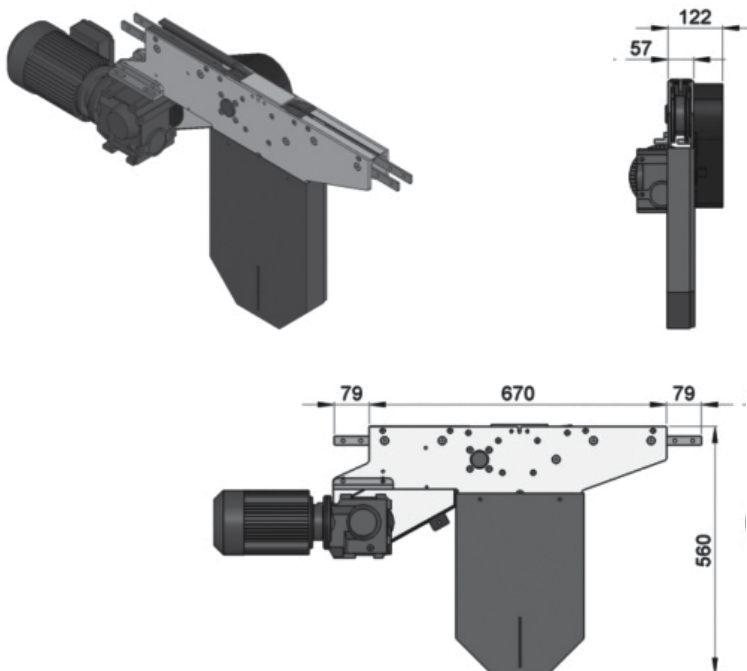

FK Suspended Catenary Drive without Motor (RIGHT)

FKCD-SD-0R

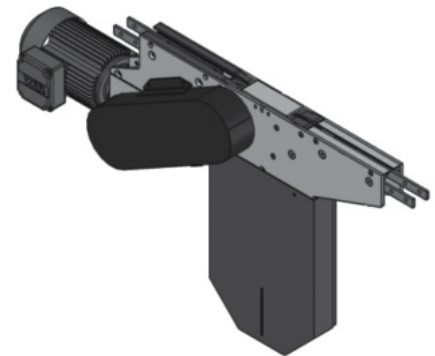

Max Traction Force: 500N

The Suspended Catenary Drive Unit is with torque limiter.

UOM: pc

Chain required 1-way: 1.4 meter
Slide rail required 1-way: 1.0 meter

SEW gearmotors are products of SEW Eurodrive

FK Direct Wheel Drive without Motor

FKWD-DD-0M

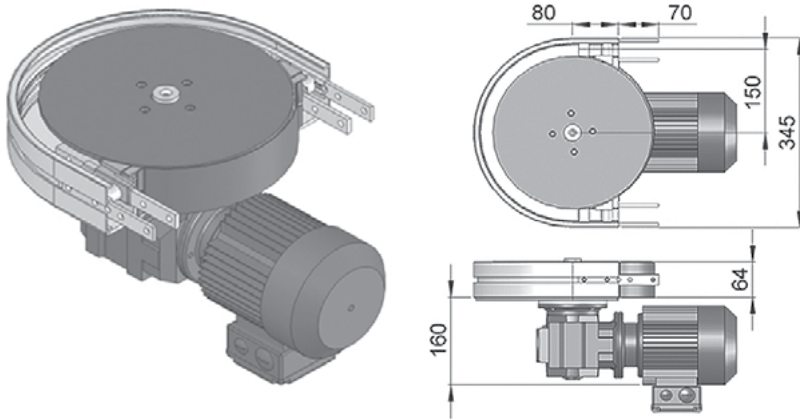

Max Traction Force: 200N

The Drive Wheel Drive Unit is without torque limiter. FKWD-DD-0M represents direct drive without gear motor. Maximum traction force for FKWD-DD is lower than FKDD and FKSD.

UOM: pc

Chain required 1-way: 0.7 meter
Slide rail required 1-way: 0.7 meter

FK Suspended Wheel Drive without Motor

FKWD-SD-0M

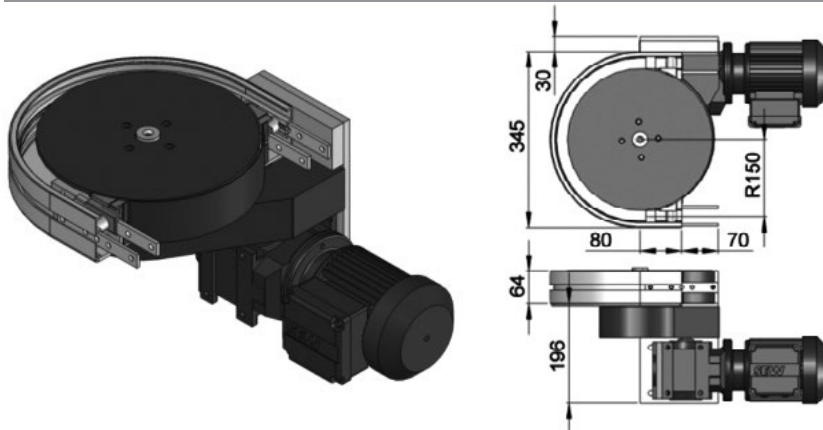

Max Traction Force: 200N

The Suspended Wheel Drive Unit is with torque limiter. FKWD-SD-0M represents direct drive without gear motor. Maximum traction force for FKWD-SD is lower than FKDD and FKSD.

UOM: pc

Chain required 1-way: 0.7 meter
Slide rail required 1-way: 0.7 meter

FK Idler End-45

FKIE-A45

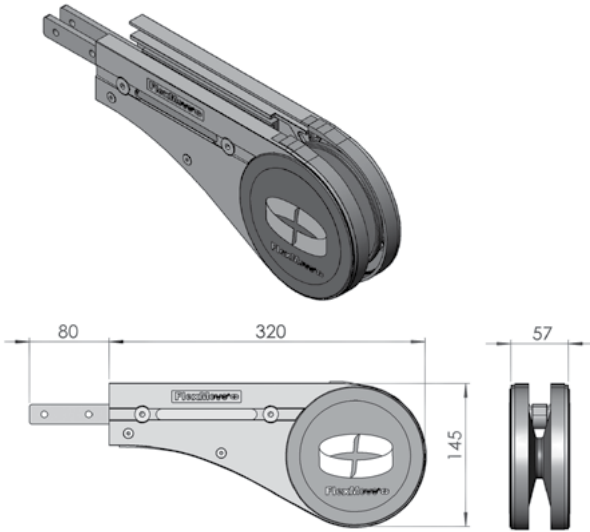

UOM: pc

Chain required 2-way: 0.8 meter
Slide rail required 2-way: 0.5meter

Note: Tail is 12 mm wider than conveyor frame.

FK Idler End-200

FKIE-200

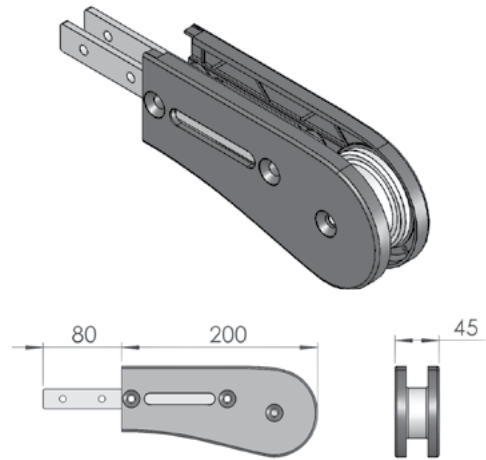

UOM: pc

Chain required 2-way: 0.7 meter
Slide rail required 2-way: 0

FK Idler-200 End Free Roller Bridge

FKIE-A45EB-200

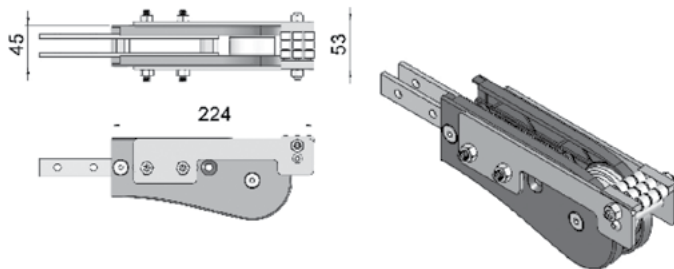

FKIEB-A45-200

End transfer bridge c/w roller for FKIE-200

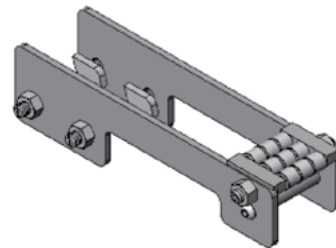

UOM: pc

SEW gearmotors are products of SEW Eurodrive

FK Wheel Bend 180°

FKWB-180R150A

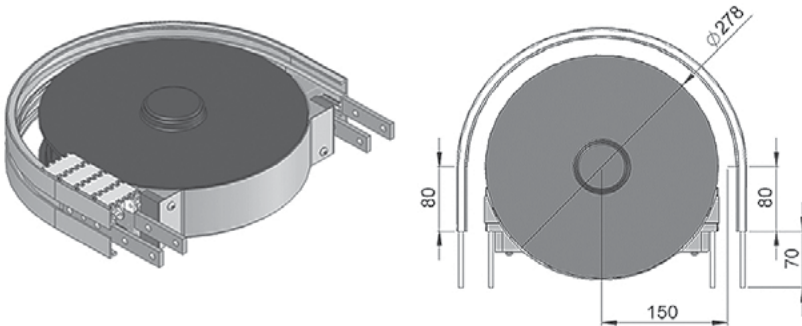

UOM: pc

Chain required 2-way: 1.3 meter
Slide rail required 2-way: 1.3 meter

FK Wheel Bend 90°

FKWB-90R150A

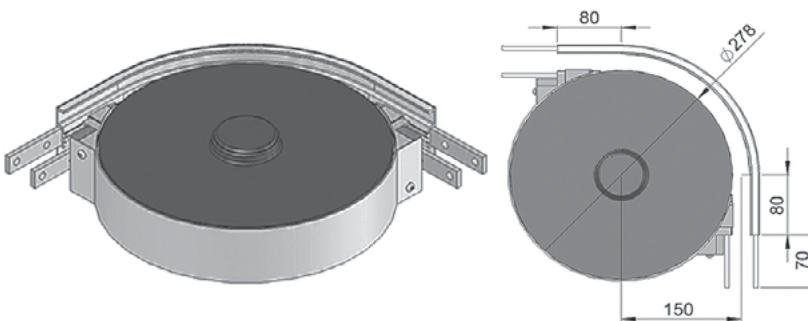

UOM: pc

Chain required 2-way: 0.8 meter
Slide rail required 2-way: 0.8 meter

FK Wheel Bend 60°

FKWB-60R150A

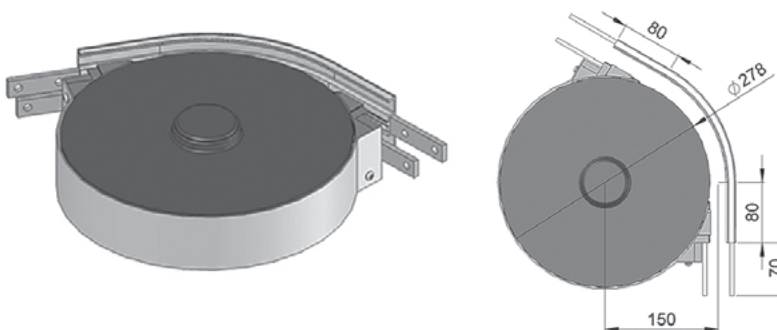

UOM: pc

Chain required 2-way: 0.6 meter
Slide rail required 2-way: 0.6 meter

FK Wheel Bend 45°

FKWB-45R150A

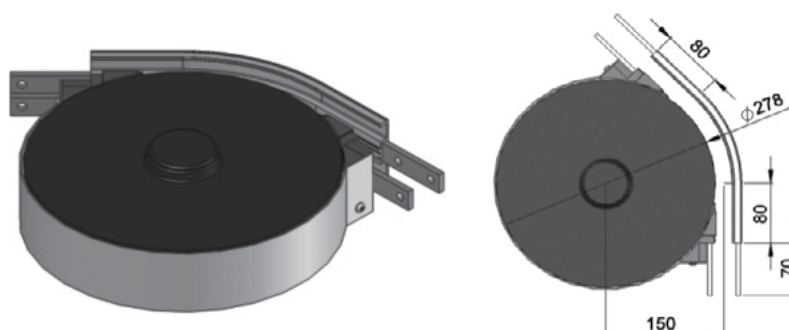

UOM: pc

Chain required 2-way: 0.6 meter
Slide rail required 2-way: 0.6 meter

FK Wheel Bend 30°

FKWB-30R150A

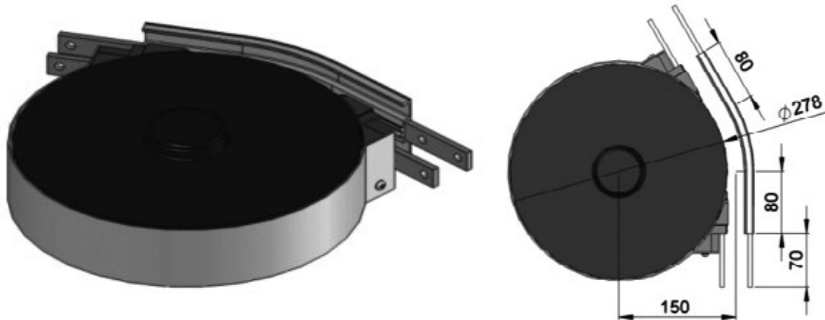

UOM: pc

Chain required 2-way: 0.5 meter
Slide rail required 2-way: 0.5 meter

FK Wheel Bend 5° - 180°

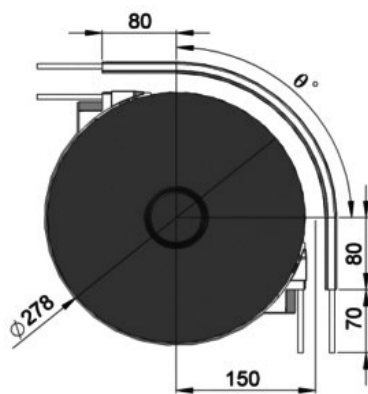

Example for FK Wheel Bend Ordering

- Wheel bend, $\text{Ø}^\circ \pm 1^\circ$
- FKWB- $\text{Ø}^\circ\text{R}150\text{A}$

If an angle of 65° is needed for wheel bend, the ordering part number is

FKWB-65R150A

The outer bend is assembled using connecting strip (FACS-20x140). Angle of Ø° must be indicated when ordering.

FK Horizontal Plain Bend 15°

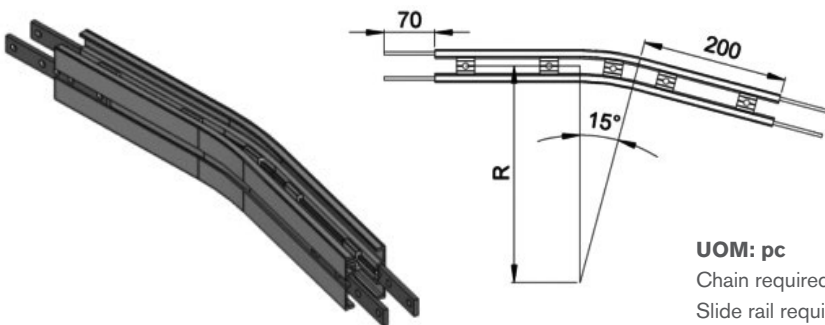

Horizontal plain bend, $15^\circ \pm 1^\circ$

R = 300 ± 10 mm	FKHB-15R300
R = 500 ± 10 mm	FKHB-15R500
R = 700 ± 10 mm	FKHB-15R700
R = 1000 ± 10 mm	FKHB-15R1000

UOM: pc

Chain required 2-way (300, 500, 700, 1000): 1, 1.1, 1.2, 1.3 meter
Slide rail required 2-way (300, 500, 700, 1000): 1.9, 2.1, 2.3, 2.6 meter

FK Horizontal Plain Bend 30°

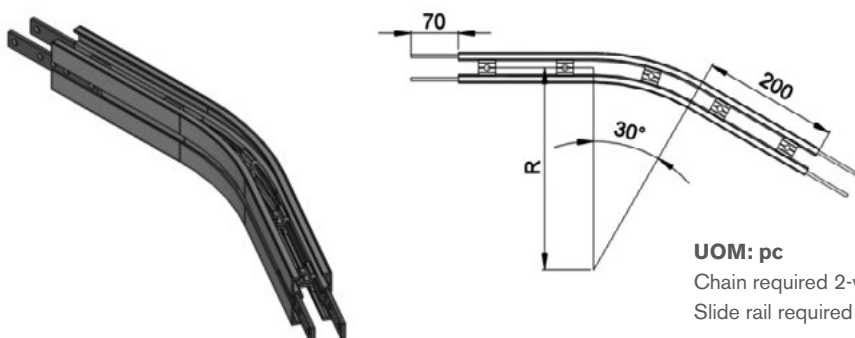

Horizontal plain bend, $30^\circ \pm 1^\circ$

R = 300 ± 10 mm	FKHB-30R300
R = 500 ± 10 mm	FKHB-30R500
R = 700 ± 10 mm	FKHB-30R700
R = 1000 ± 10 mm	FKHB-30R1000

UOM: pc

Chain required 2-way (300, 500, 700, 1000): 1.1, 1.3, 1.5, 1.8 meter
Slide rail required 2-way (300, 500, 700, 1000): 2.2, 2.6, 3.1, 3.7 meter

FK Horizontal Plain Bend 45°

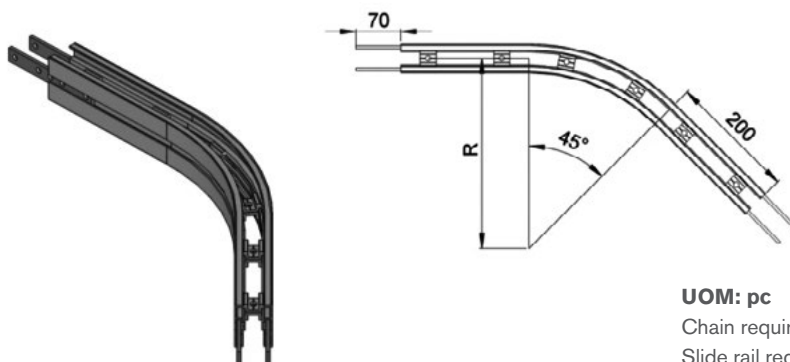

Horizontal plain bend, 45° ± 1°

R = 300 ± 10 mm	FKHB-45R300
R = 500 ± 10 mm	FKHB-45R500
R = 700 ± 10 mm	FKHB-45R700
R = 1000 ± 10 mm	FKHB-45R1000

UOM: pc

Chain required 2-way (300, 500, 700, 1000): 1.3, 1.6, 1.9, 2.4 meter
 Slide rail required 2-way (300, 500, 700, 1000): 2.5, 3.2, 3.8, 4.7 meter

FK Horizontal Plain Bend 60°

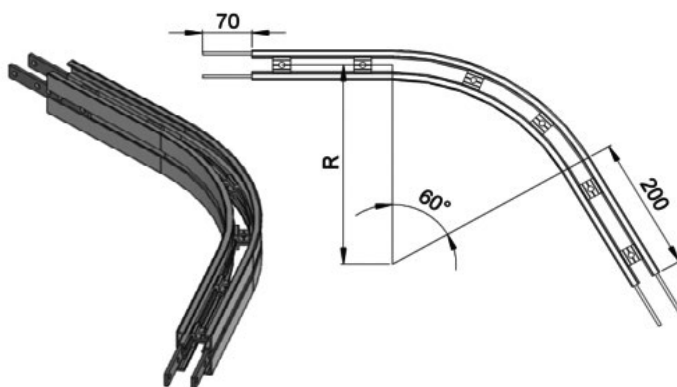

Horizontal plain bend, 60° ± 1°

R = 300 ± 10 mm	FKHB-60R300
R = 500 ± 10 mm	FKHB-60R500
R = 700 ± 10 mm	FKHB-60R700
R = 1000 ± 10 mm	FKHB-60R1000

UOM: pc

Chain required 2-way (300, 500, 700, 1000): 1.4, 1.8, 2.3, 2.9 meter
 Slide rail required 2-way (300, 500, 700, 1000): 2.9, 3.7, 4.5, 5.8 meter

FK Horizontal Plain Bend 90°

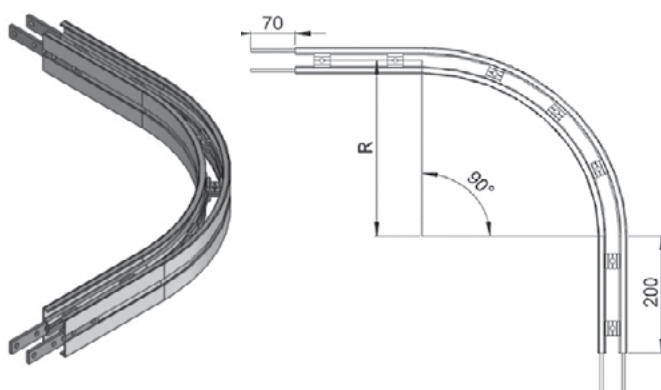

Horizontal plain bend, 90° ± 1°

R = 300 ± 10 mm	FKHB-90R300
R = 500 ± 10 mm	FKHB-90R500
R = 700 ± 10 mm	FKHB-90R700
R = 1000 ± 10 mm	FKHB-90R1000

UOM: pc

Chain required 2-way (300, 500, 700, 1000): 1, 1.1, 1.2, 1.3 meter
 Slide rail required 2-way (300, 500, 700, 1000): 1.9, 2.1, 2.3, 2.6 meter

FK Horizontal Plain Bend 180°

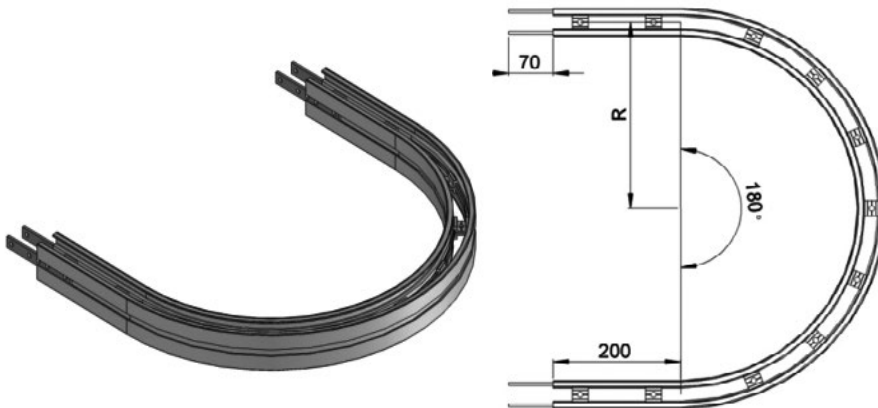

Horizontal plain bend, 180° ± 1°

R = 300 ± 10 mm	FKHB-180R300
R = 500 ± 10 mm	FKHB-180R500
R = 700 ± 10 mm	FKHB-180R700
R = 1000 ± 10 mm	FKHB-180R1000

UOM: pc

Chain required 2-way (300, 500, 700, 1000): 2.7, 3.9, 5.2, 7.1 meter

Slide rail required 2-way (300, 500, 700, 1000): 5.4, 7.9, 10.4, 14.2 meter

FK Horizontal Plain Bend 5-180°

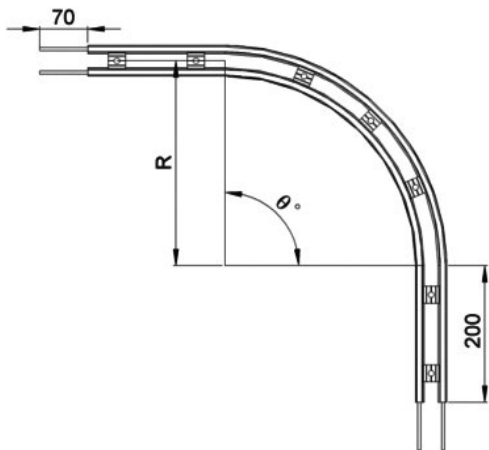

Example for FK Horizontal Plain Bend Ordering

Horizontal plain bend, $\theta^\circ \pm 1^\circ$

R = 300 ± 10 mm	FKHB- θ°R300
R = 500 ± 10 mm	FKHB- θ°R500
R = 700 ± 10 mm	FKHB- θ°R700
R = 1000 ± 10 mm	FKHB- θ°R1000

If an angle of 120° is needed for radius R500 horizontal plain bend, the ordering part number is

FKHB-120R500

UOM: pc

Chain required 2-way (300, 500, 700, 1000): meter (Variable to angle)

Slide rail required 2-way (300, 500, 700, 1000): meter (Variable to angle)

FK Vertical Bend 5° - 90°

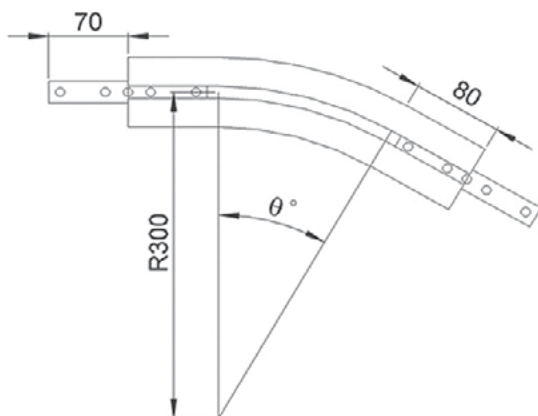

Example for FK Vertical Bend Ordering

- Vertical bend, $\theta^\circ \pm 1^\circ$
- FKVB- θ° R300

If an angle of 65° is needed for vertical bend, the ordering part number is

FKVB-65R300

The outer bend is assembled using connecting strip (FACS-20x140). Angle of θ° must be indicated when ordering.

FK Vertical Bend 5°

FKVB-5R300

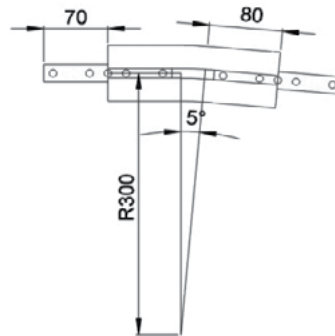
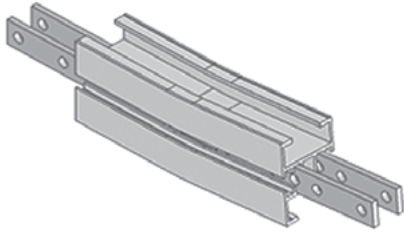

UOM: pc

Chain required 2-way: 0.4 meter
Slide rail required 2-way: 0.7 meter

FK Vertical Bend 10°

FKVB-10R300

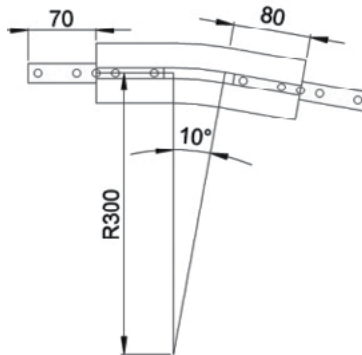
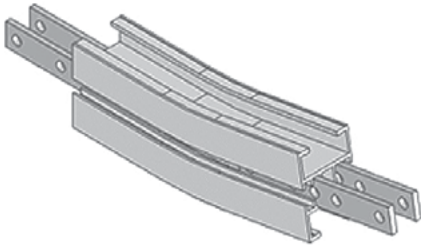

UOM: pc

Chain required 2-way: 0.4 meter
Slide rail required 2-way: 0.8 meter

FK Vertical Bend 15°

FKVB-15R300

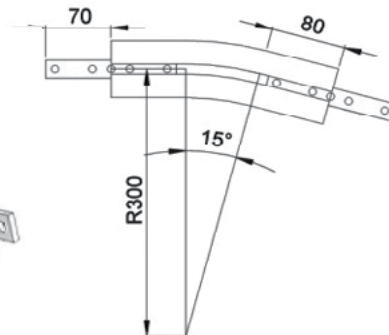
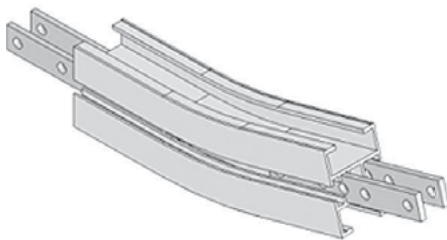

UOM: pc

Chain required 2-way: 0.5 meter
Slide rail required 2-way: 1.0 meter

FK Vertical Bend 20°

FKVB-20R300

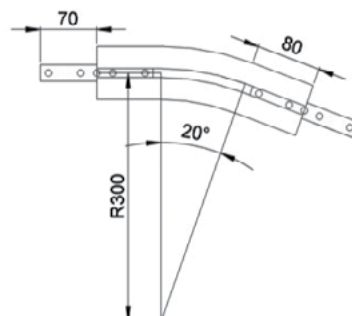
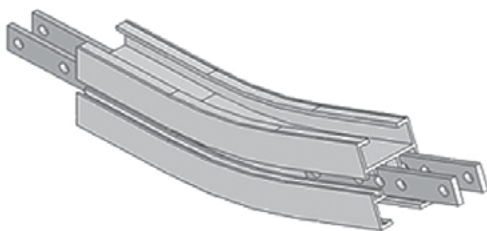

UOM: pc

Chain required 2-way: 0.5 meter
Slide rail required 2-way: 1.1 meter

FK Vertical Bend 30°

FKVB-30R300

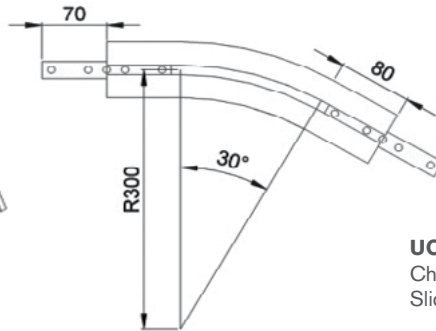
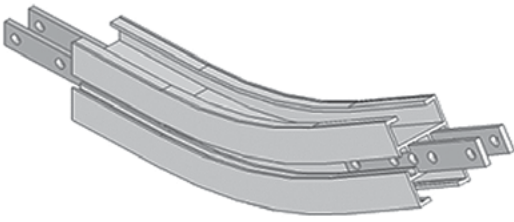

UOM: pc

Chain required 2-way: 0.6 meter
Slide rail required 2-way: 1.3 meter

FK Vertical Bend 45°

FKVB-45R300

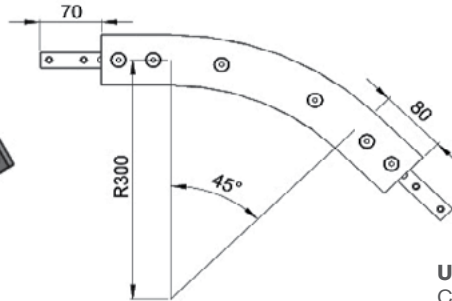
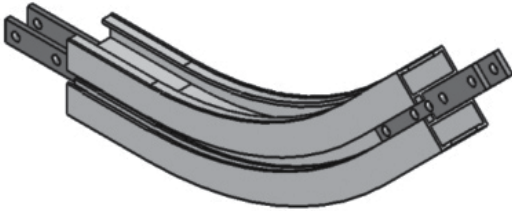

UOM: pc

Chain required 2-way: 0.8 meter
Slide rail required 2-way: 1.6 meter

FK Vertical Bend 60°

FKVB-60R300

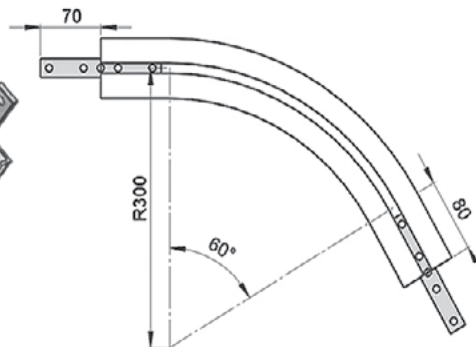

UOM: pc

Chain required 2-way: 0.9 meter
Slide rail required 2-way: 1.9 meter

FK Vertical Bend 90°

FKVB-90R300

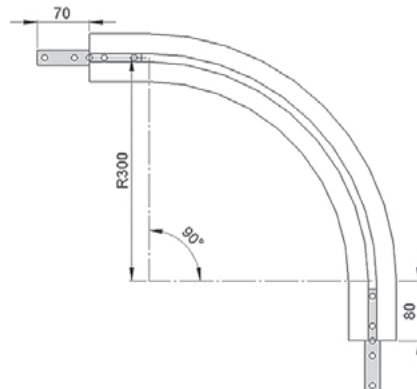
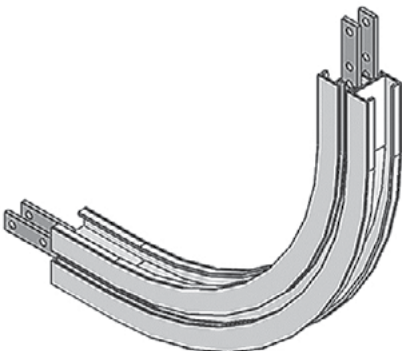

UOM: pc

Chain required 2-way: 1.3 meter
Slide rail required 2-way: 2.5 meter

FK X In-Line Transfer Module

FKXT-045

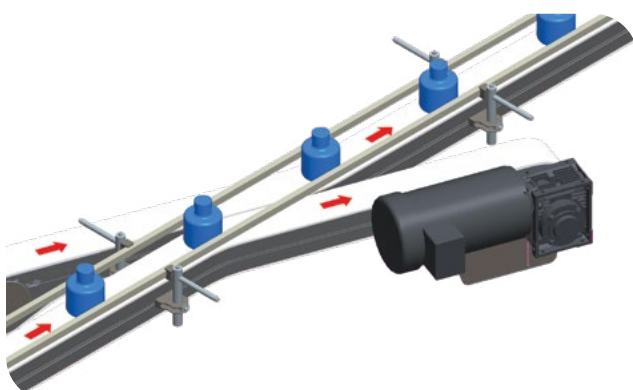

- X In-Line Modules provide a standard, compact way to side transfer product from conveyor to conveyor.
- Straight guiding is placed across the transfer module for smooth In-Line product flow
- Conveyors are mounted together to provide a smooth transfer even for small products
- X In-Line transfers are compact in the length direction

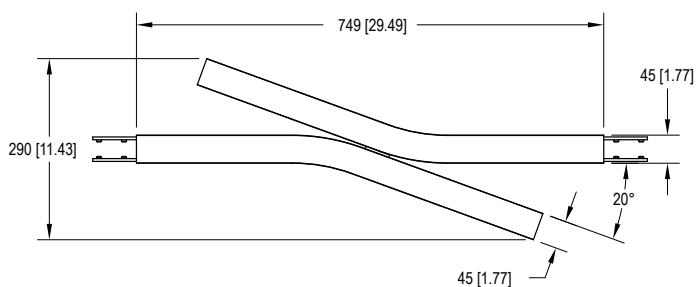

Variety of chain types suitable for wide range of applications either horizontal or vertical product transportation. The maximum product width to be conveyed can be referred to guide rail assembly pages.

FS Series Characteristic

Beam Width: 65 mm

Product Width: Refer to Guide Rail Assembly

Accessories Needed

Slide Rail Required: FASR-25 OR FASR-25U

Slide Rail Color: White or Natural Color

Slide Rail Material: HDPE OR UHMW-PE

Slide Rail Rivet & Screw: FASLR-4X6 or FASLS-M5

Connecting strip is used to connect two beams.

Connecting Strip: FACS-25x140A

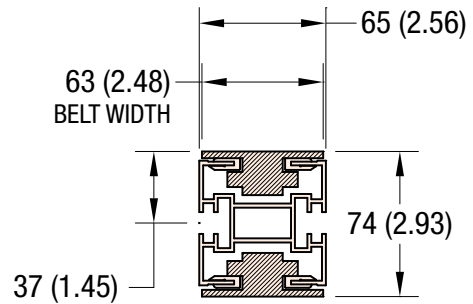

65 MM WIDTH

Conveyor Beam FSCB-3

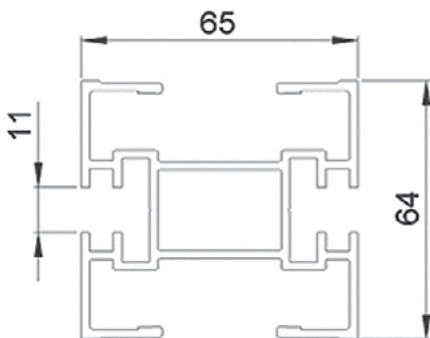

UOM: 3 Meter / Length

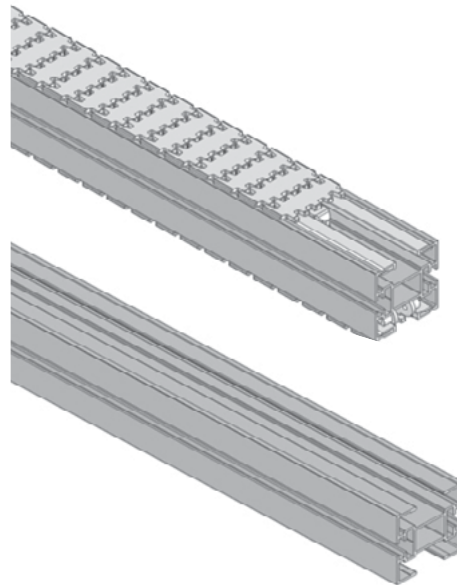

Chain Connecting Module FSCC-160

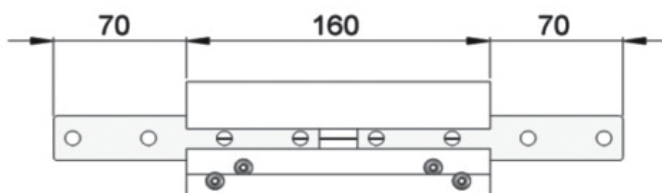

UOM: pc

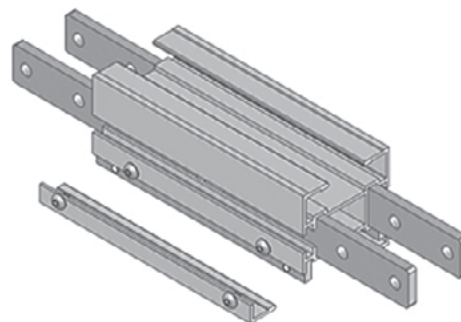

Chain Common Data

Packaging: 5 m per box

Pitch: 25.4 mm

Width: 63 mm

Tensile Strength at 20°C: 4000N

Color: White & Black (Conductive)

Material:

Chain: White Acetal / POM

Pivot: Polyamide

Pivot Pin: Stainless Steel

Insert (Wedge & Friction): TPE Grey

Example for FSCT-5A17-L#

= 1 cleated top chain with alternate of # link of plain chain

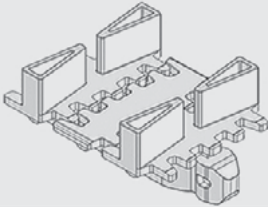

The above chain is FSCT-5A17-L1, 1 link cleated top chain with alternate of 1 link of plain chain.

Note: # = 1, 2, 3, 4, 5.....20

Standard Plain Chain **FSPC-5**

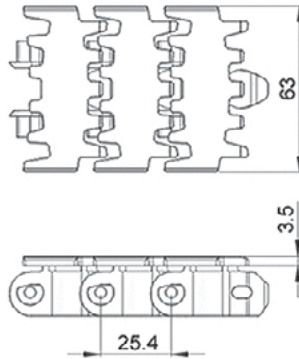
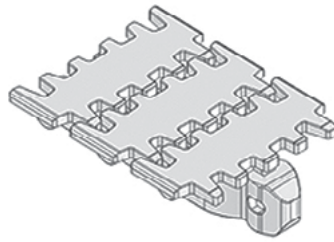

UOM: 5 Meter / box

Application: Suitable for horizontal and slope < 5° transport of products with accumulation.

Universal Chain **FSUC-5**

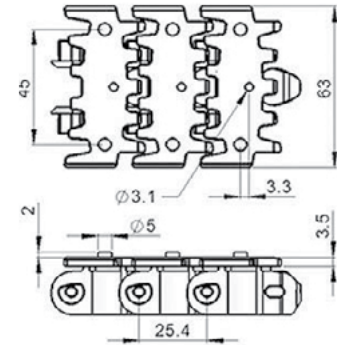
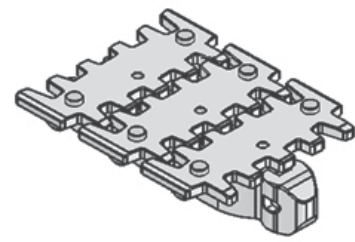

UOM: 5 Meter / box

Application: Universal Link with M3 Nut, Suitable for attached customer cleat or fixture

Wedge Top Chain **FSWT-5A**

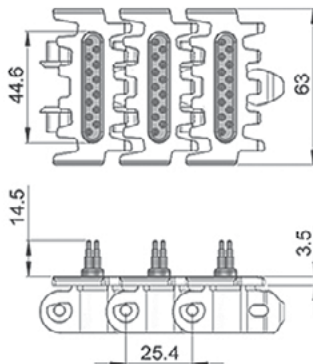
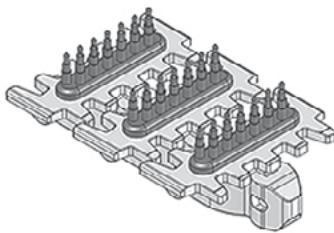

UOM: 5 Meter / box

Application: Vertical Wedge transportation of products.

Wedge Top Chain **FSWT-5C**

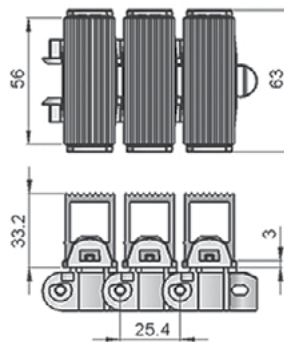
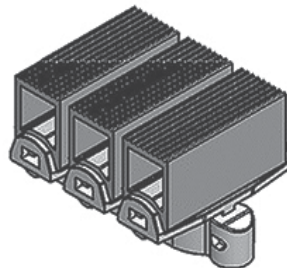

UOM: 5 Meter / box

Application: Vertical Wedge transportation of products. (Heavy Duty).

Wedge Top Chain **FSWT-5D**

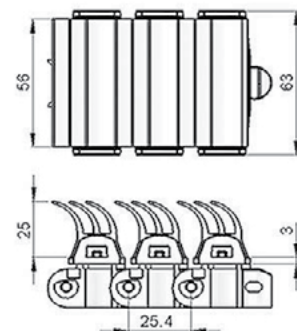
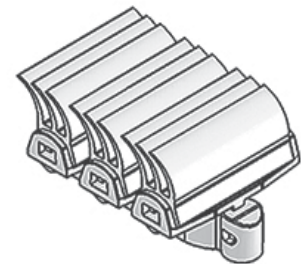

UOM: 5 Meter / box

Application: Vertical Wedge transportation of products.

Friction Top Chain **FSFT-5**

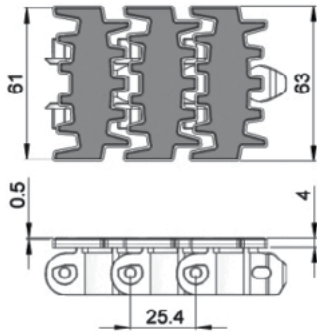
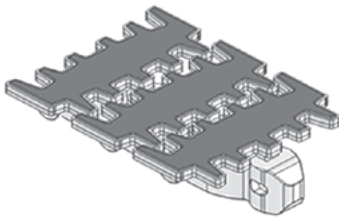

UOM: 5 Meter / box

Application: Suitable for transport product in slope $> 5^\circ$ but $\leq 30^\circ$ without accumulation.

Friction Top Chain **FSFT-5C**

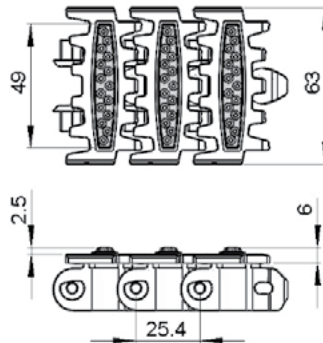
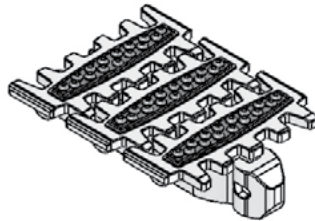

UOM: 5 Meter / box

Application: Suitable for transport product in slope $> 5^\circ$ but $\leq 35^\circ$ without accumulation. Subject to product weight and packing

Twist Chain **FSPC-5M**

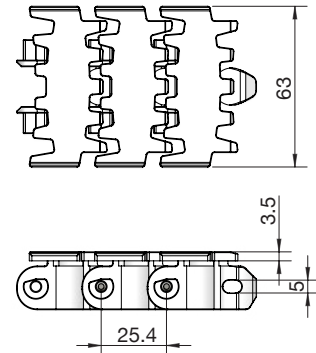
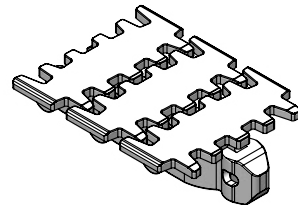

UOM: 5 Meter / box

Application: Suitable twist conveyor beam; horizontal and slope $< 5^\circ$ transport of products with accumulation

Conductive Chain **FSPC-5CD**

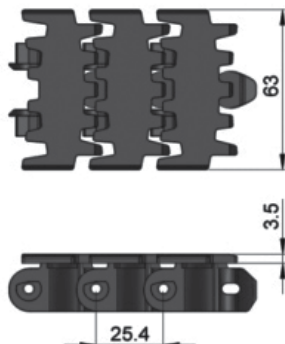
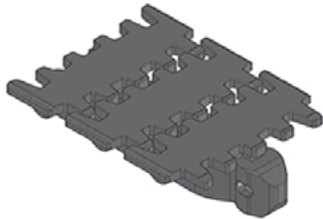

UOM: 5 Meter / box

Application: Suitable for transport of static sensitive product.

Flocked Chain **FSFK-5**

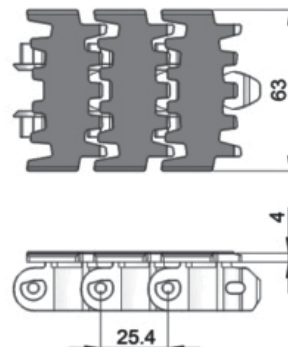
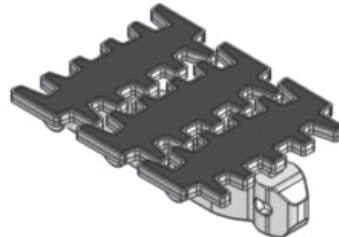

UOM: 5 Meter / box

Application: Suitable to transport lightweight, fragile and scratch sensitive product.

Cleat Top Chain-A FSCT-5A17-L#

= 1, 2, 3, 4, 5.....20

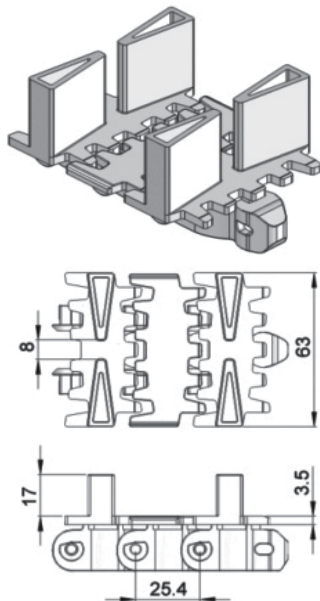

UOM: 5 Meter / box

Application: Suitable for vertical transport of product with no accumulation.

Cleat Top Chain-A FSCT-5A30-L#

= 1, 2, 3, 4, 5.....20

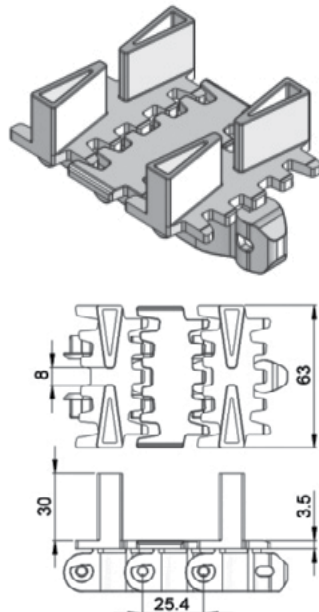

UOM: 5 Meter / box

Application: Suitable for vertical transport of product with no accumulation.

Cleat Top Chain-B FSCT-5B

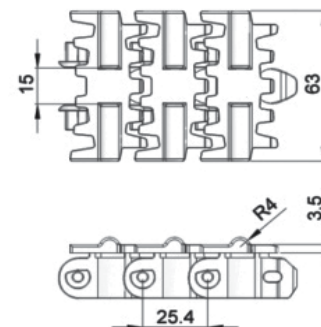
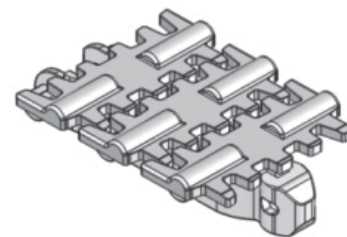

UOM: 5 Meter / box

Application: Suitable Cigarette transport.

Cleat Top Chain-C FSCT-5C

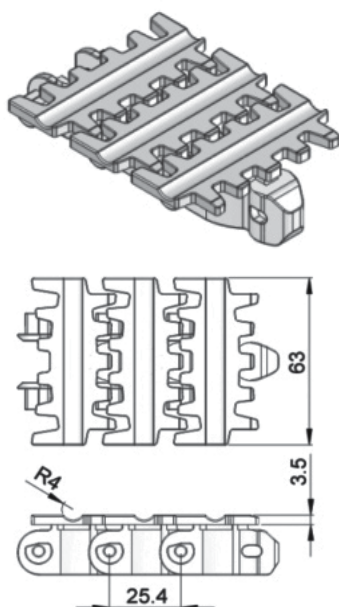

UOM: 5 Meter / box

Application: Suitable for Cigarette transport.

Magnet Top Chain FSMT-5

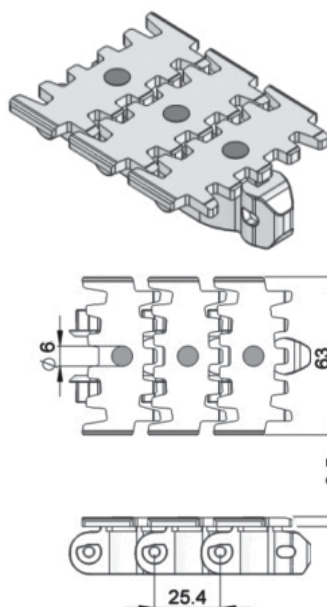

UOM: 5 Meter / box

Application: Suitable for conveying ferromagnetic products in slope.

Magnet Top Chain FSMT-5-L#

= 1, 2, 3, 4, 5.....20

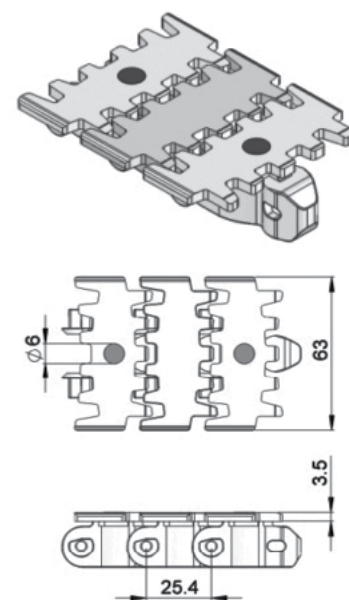

UOM: 5 Meter / box

Application: Suitable for conveying ferromagnetic products in slope.

Stainless Steel Top Chain **FSST-5S**

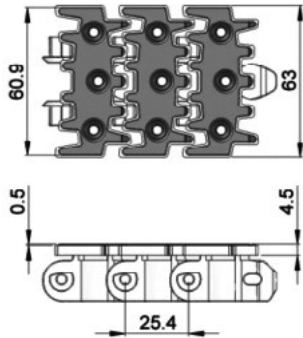
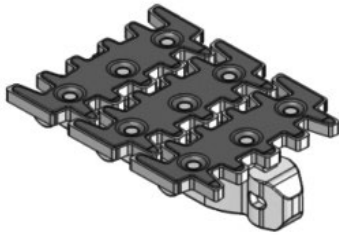

UOM: 5 Meter / box

Application: Suitable to transport metal products in accumulation.

Roller Top Chain **FSRT-5**

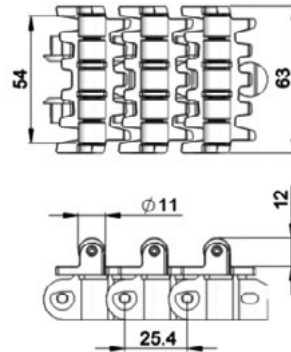
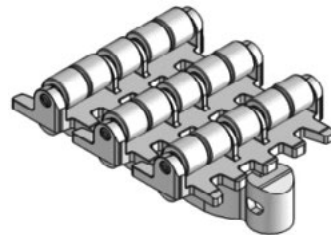

UOM: 5 Meter / box

Application: Suitable for accumulation of product with low friction and pressure.

Roller Cleat Chain **FSRC-5A-L#**

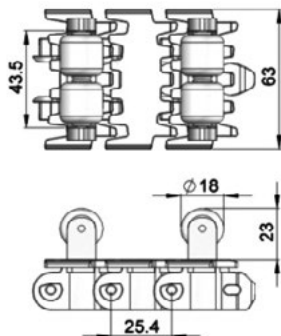
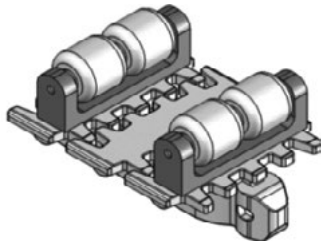

UOM: 5 Meter / box

Application: Suitable for vertical transportation, of product in slope with no accumulation.

FS Direct End Drive without Motor (LEFT)

FSDD-A65-XDY (See Chart)

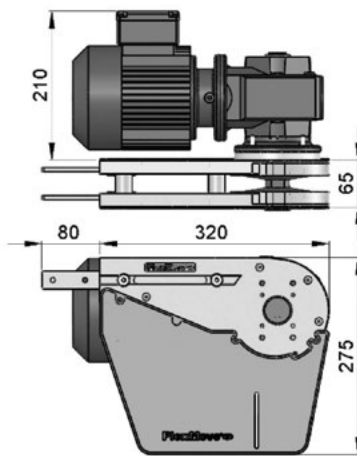
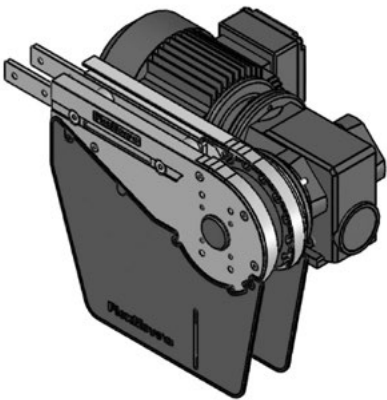

FS Direct End Drive without Motor (RIGHT)

FSDD-A65-XDY (See Chart)

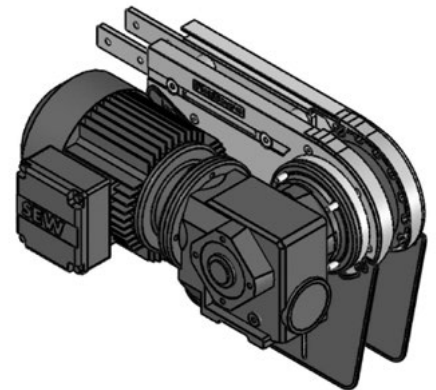

Part Number		Shaft Selection	Direction	Aux Shaft Selection
FSDD-A65	-	X	D	Y
		0 = 20 mm	L = Left	Blank = No Aux Shaft
		E = 3/4 in*	R = Right	A = 20 mm Aux Shaft
		A = 20 mm Aux Only		

*3/4 inch shaft option available in North America only.

Max Traction Force: 500N

The Drive End Drive Unit is without torque limiter.

UOM: pc

Chain required 2-way: 0.8 meter
Slide rail required 2-way: 0.5 meter

FS Direct End Drive without Motor GP (LEFT)

FSDD-A65GP-XDY (See Chart)

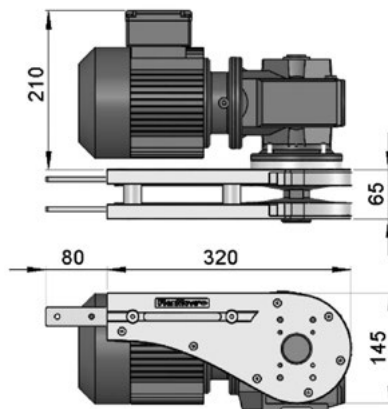
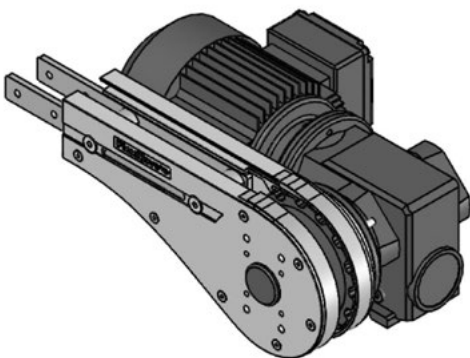

FS Direct End Drive without Motor GP (RIGHT)

FSDD-A65GP-XDY (See Chart)

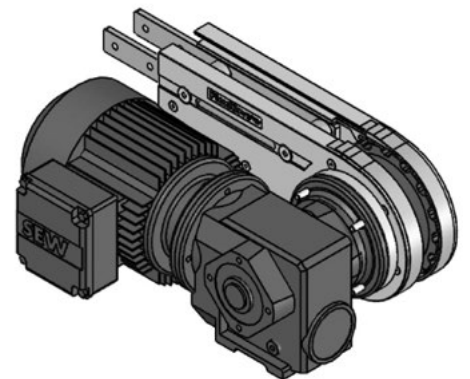

Requires the use of connecting or weighted take-up module for chain maintenance.

Part Number		Shaft Selection	Direction	Aux Shaft Selection
FSDD-A65GP	-	X	D	Y
		0 = 20 mm	L = Left	Blank = No Aux Shaft
		E = 3/4 in*	R = Right	A = 20 mm Aux Shaft
		A = 20 mm Aux Only		

*3/4 inch shaft option available in North America only.

Max Traction Force: 500N

The Direct End Drive Unit GP is without torque limiter.

UOM: pc

Chain required 2-way: 0.8 meter
Slide rail required 2-way: 0.5 meter

SEW gearmotors are products of SEW Eurodrive

FS Direct with Power Transfer Motor (LEFT)
FSDD-A65PT-XD (See Chart)

FS Direct with Power Transfer Motor (RIGHT)
FSDD-A65PT-XD (See Chart)

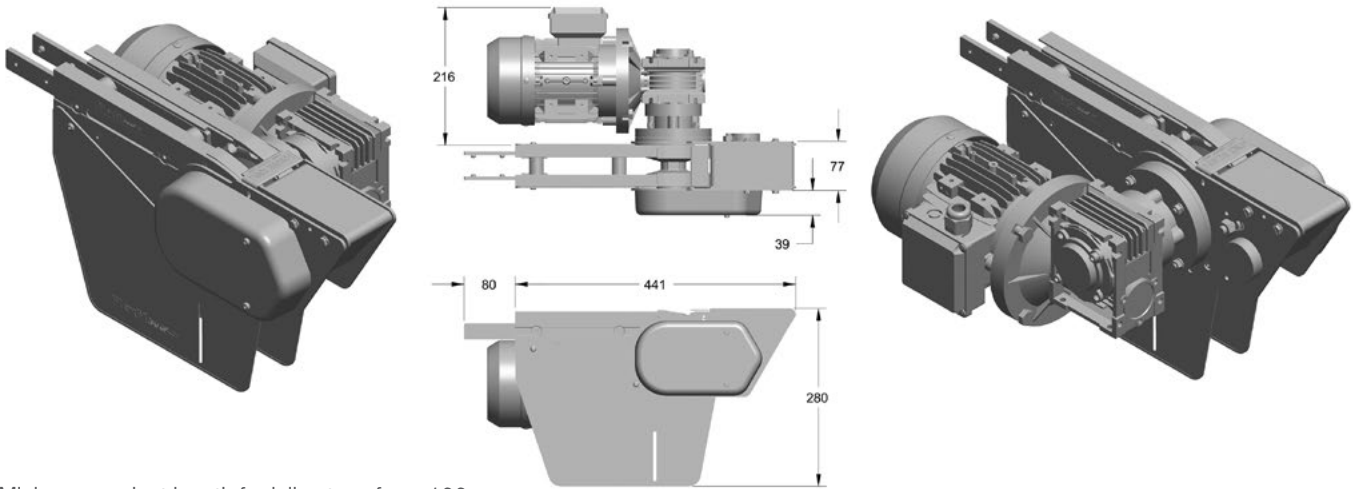

Minimum product length for inline transfer = 100 mm
 Maximum speed is 30 m/min (100 ft/min)
 Only one power transfer needed on either infeed or discharge trail required for end to end transfer.
 Provides extended transfer nose for interfacing with large rollers.

Max Traction Force: 500N
 The Drive End Drive Unit is without torque limiter.

UOM: pc
 Chain required 2-way: 0.8 meter
 Slide rail required 2-way: 0.5 meter

Part Number		Shaft Selection	Direction
FSDD-A65PT	-	X	D
		0 = 20 mm	L = Left
		E = 3/4 in*	R = Right

*3/4 inch shaft option available in North America only.

FS GP Direct with Power Transfer Motor (LEFT)
FSDD-A65GPPT-XD (See Chart)

FS GP Direct with Power Transfer Motor (RIGHT)
FSDD-A65GPPT-XD (See Chart)

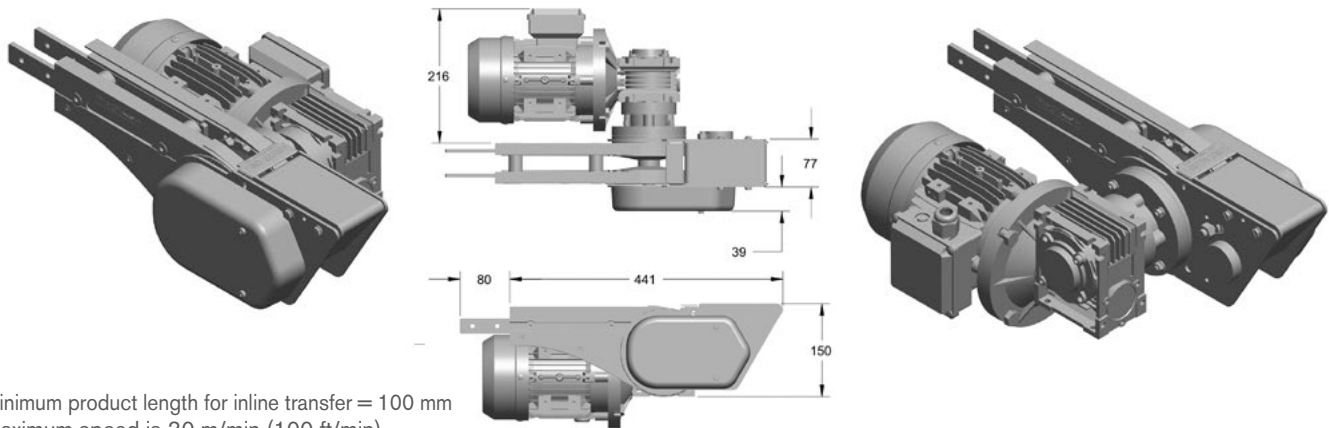

Minimum product length for inline transfer = 100 mm
 Maximum speed is 30 m/min (100 ft/min)
 Only one power transfer needed on either infeed or discharge trail required for end to end transfer.
 Provides extended transfer nose for interfacing with large rollers.
 Requires the use of connecting or weighted take-up module for chain maintenance.

Max Traction Force: 500N
 The Direct End Drive Unit GP is without torque limiter.

UOM: pc
 Chain required 2-way: 0.8 meter
 Slide rail required 2-way: 0.5 meter

Part Number		Shaft Selection	Direction
FSDD-A65GPPT	-	X	D
		0 = 20 mm	L = Left
		E = 3/4 in*	R = Right

*3/4 inch shaft option available in North America only.

SEW gearmotors are products of SEW Eurodrive

FS Direct Drive Driven Transfer Bridge (LEFT)

FSDD-A65DB-A-0L

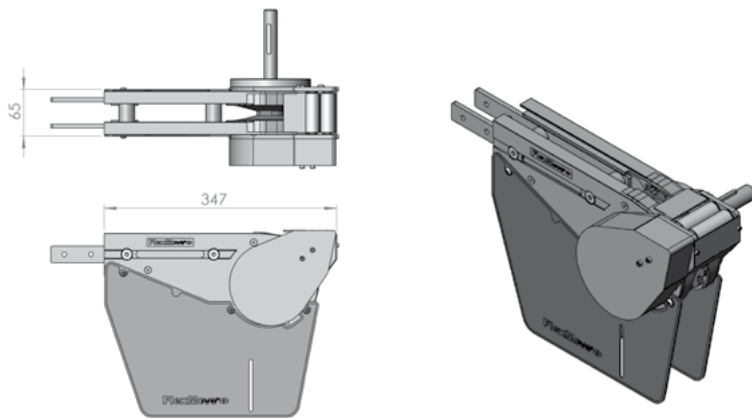

UOM: pc

20 mm Shaft only.
 Minimum product length for inline transfer = 100 mm
 Transfer extends past conveyor only 27 mm

FS Direct Drive Driven Transfer Bridge (RIGHT)

FSDD-A65DB-A-0R

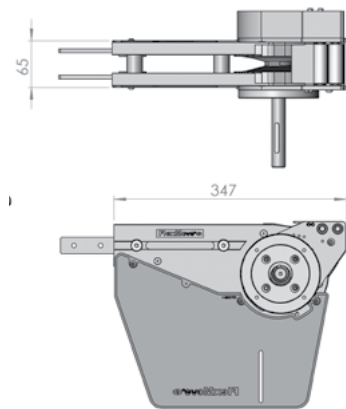

Max Traction Force: 500N

The Drive End Drive Unit is without torque limiter.

UOM: pc

Chain required 2-way: 0.8 meter
 Slide rail required 2-way: 0.5 meter

FS Direct Drive Free Roller Transfer Bridge

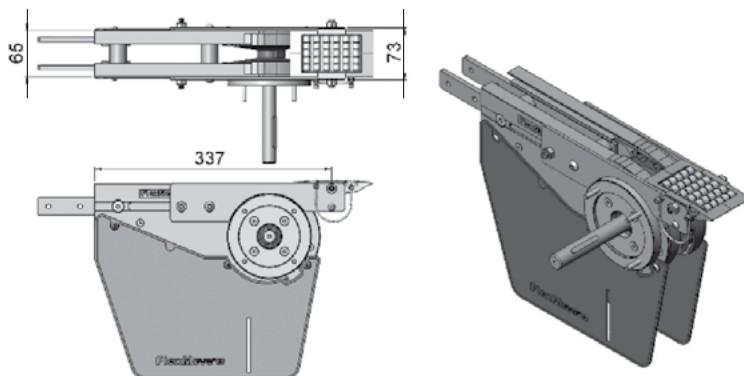

Roller transfer bridge is sold separately.

FSTB-A65

Transfer bridge c/w roller for FSIE-A65, FSDD-A65-XDY and FSDD-A65GP-XDY-

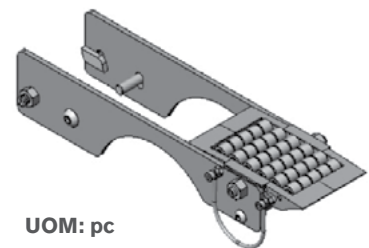

UOM: pc

FS Direct Drive End Free Roller Bridge (LEFT/RIGHT)

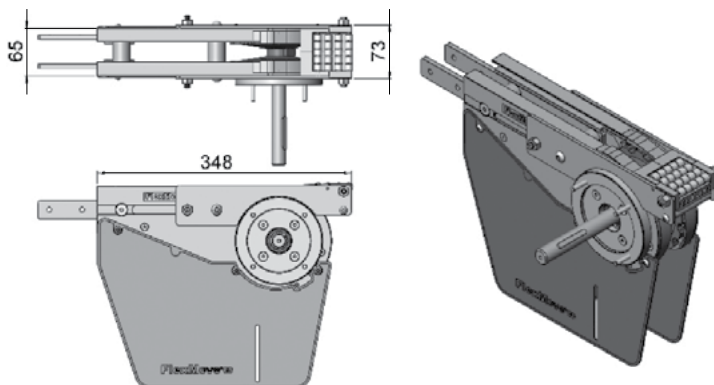

Roller transfer bridge is sold separately.

FSEB-A65

End transfer bridge c/w roller for FSIE-A65, FSDD-A65-XDY and FSDD-A65GP-XDY

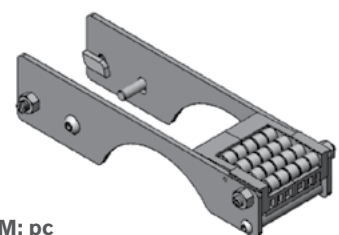

UOM: pc

SEW gearmotors are products of SEW Eurodrive

FS Suspended End Drive without Motor (LEFT)

FSSD-A65-0L (with Torque Limiter)
FSSD-A65SPT-0L (without Torque Limiter)

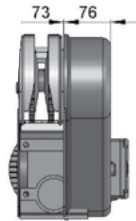
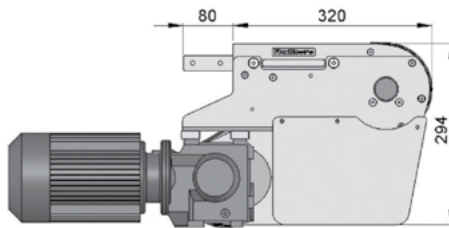
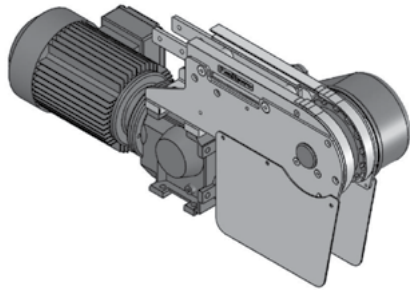

- Locates gearmotor below conveyor for compact applications.
- Includes torque limiter protecting chain and motor from overload.
- Maintains chain pull capacity at 500N.

FS Suspended End Drive without Motor (RIGHT)

FSSD-A65-0R (with Torque Limiter)
FSSD-A65SPT-0R (without Torque Limiter)

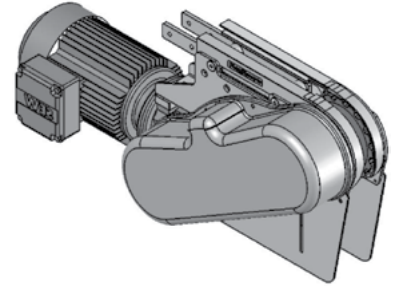

Max Traction Force: 500N

The Suspended End Drive Unit is available with and without torque limiter.

UOM: pc

Chain required 2-way: 0.8 meter
Slide rail required 2-way: 0.5 meter

FS Direct Intermediate Drive without Motor (LEFT)

FSID-DD-0L1

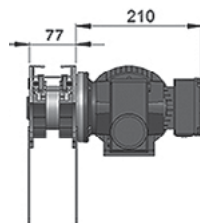
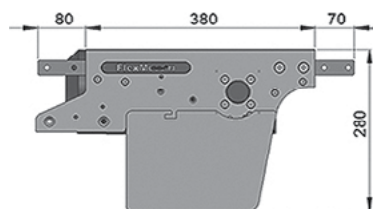
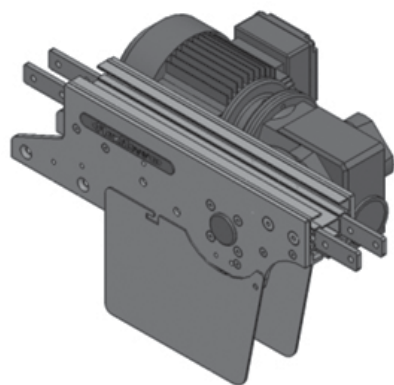

Located in middle section of conveyor to free up drive end.

FS Direct Intermediate Drive without Motor (RIGHT)

FSID-DD-0R1

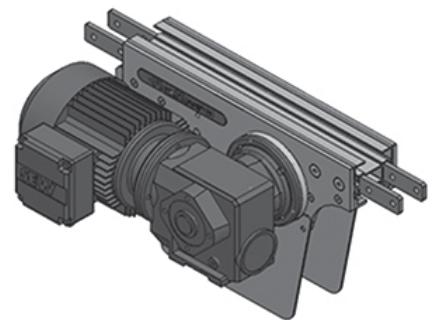

Max Traction Force: 200N

The Direct Intermediate Drive Unit is without torque limiter.

SEW gearmotors are products of SEW Eurodrive

FS Suspended Intermediate Drive without Motor (LEFT)

FSID-SD-0L1

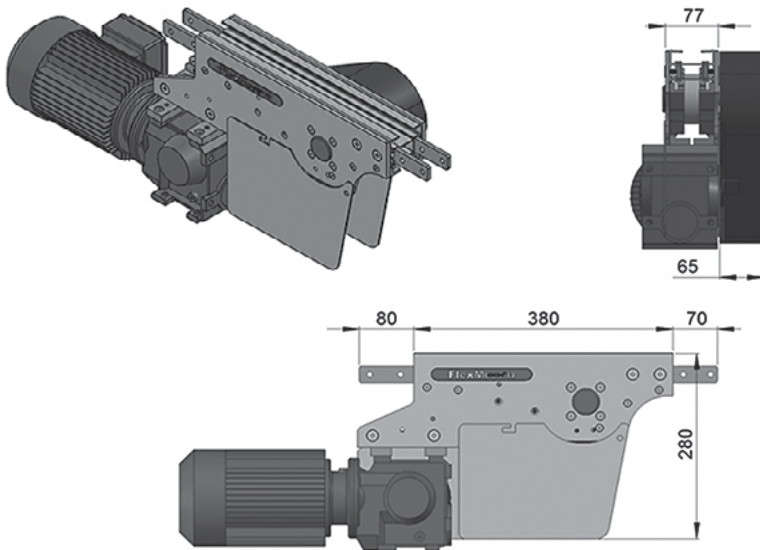

- Located in middle of conveyor to free up drive end.
- Includes torque limiter protecting chain and motor from overload.
- Limits chain pull capacity at 200N.

FS Suspended Intermediate Drive without Motor (RIGHT)

FSID-SD-0R1

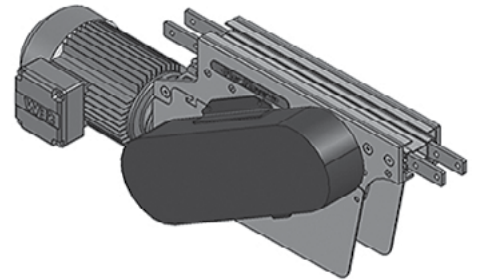

Max Traction Force: 200N
The Suspended Intermediate Drive Unit is with torque limiter.

UOM: pc
Chain required 2-way: 1.2 meter
Slide rail required 2-way: 1.1 meter

FS Combined Suspended Drive & Idler (LEFT)

FSCDI-SD-A65-0L

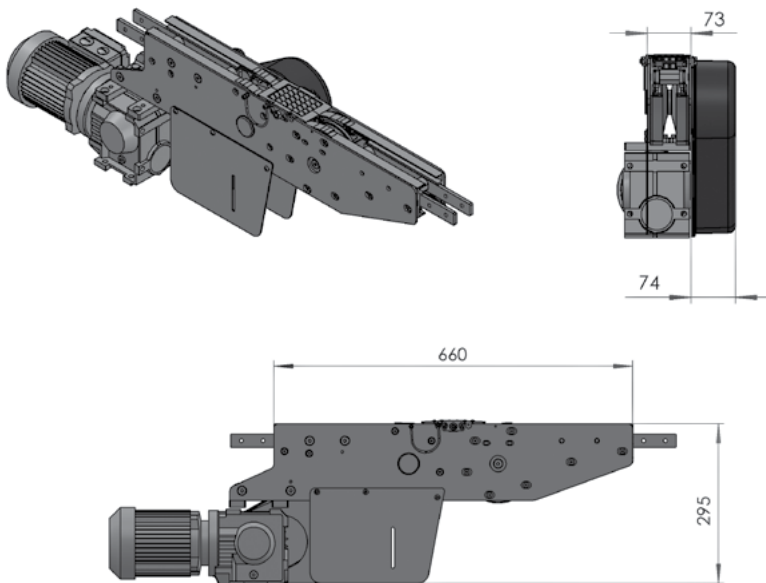

- Located in middle of conveyor to free up drive end.
- Includes torque limiter protecting chain and motor from overload.
- Limits chain pull capacity at 500N.

FS Combined Suspended Drive & Idler (RIGHT)

FSCDI-SD-A65-0R

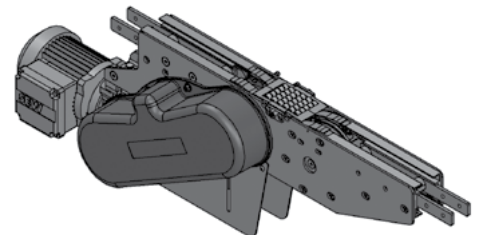

Max Traction Force: 500N
The Combine Suspended End Drive Unit is with torque limiter.

UOM: pc
Chain required 2-way: 1.6 meter
Slide rail required 2-way: 1.0 meter

SEW gearmotors are products of SEW Eurodrive

FS Suspended Catenary Drive without Motor (LEFT)

FSCD-SD

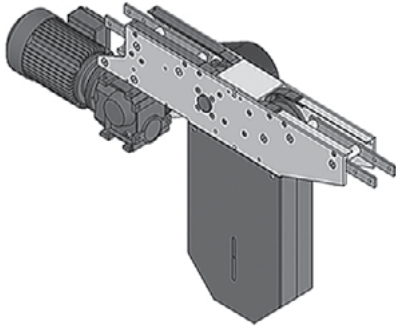

FS Suspended Catenary Drive without Motor (RIGHT)

FSCD-SD

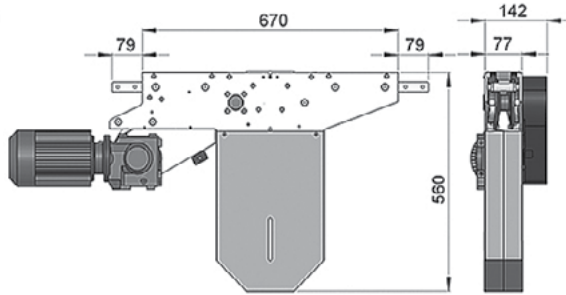
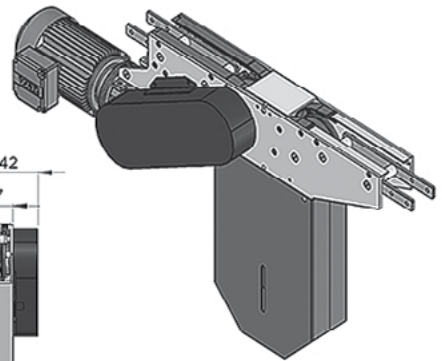

Max Traction Force: 500N

The Suspended Catenary Drive Unit is without torque limiter.

UOM: pc

Chain required 1-way: 1.4 meter
Slide rail required 1-way: 1.0 meter

FS Combined Direct Drive & Idler (LEFT)

FSCDI-DD-A65

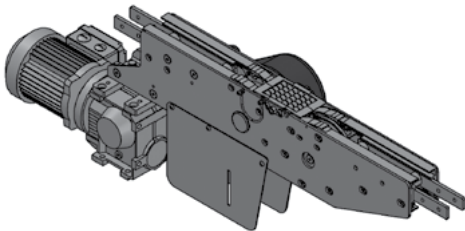

FS Combined Direct Drive & Idler (RIGHT)

FSCDI-DD-A65

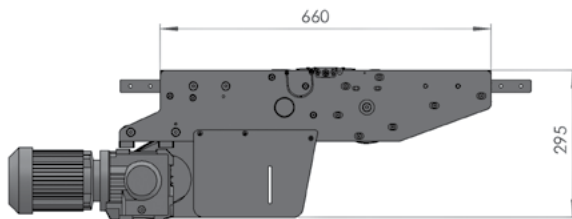
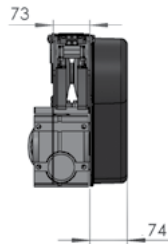
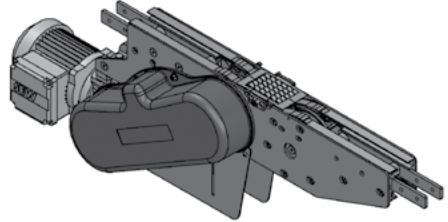

Max Traction Force: 500N

The Combine Direct End Drive Unit is without torque limiter.

UOM: pc

Chain required 2-way: 1.6 meter
Slide rail required 2-way: 1.0 meter

SEW gearmotors are products of SEW Eurodrive

FS Weighted Take-up Module

FS-WTU-700



- Provides automatic chain stretch take-up
- Reduces noise caused from catenary tail
- Must be used with GP Drive End, sold separately
- Used on conveyors over 12 M long

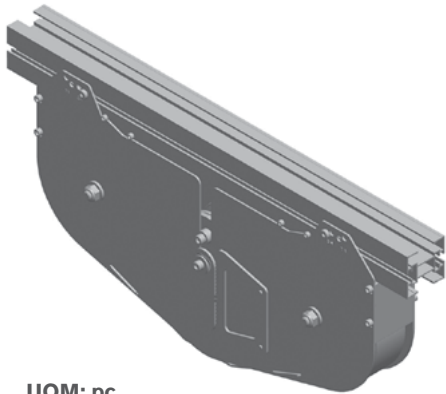

UOM: pc
Chain required 1.5 meter
Slide rail required 2.1 meter

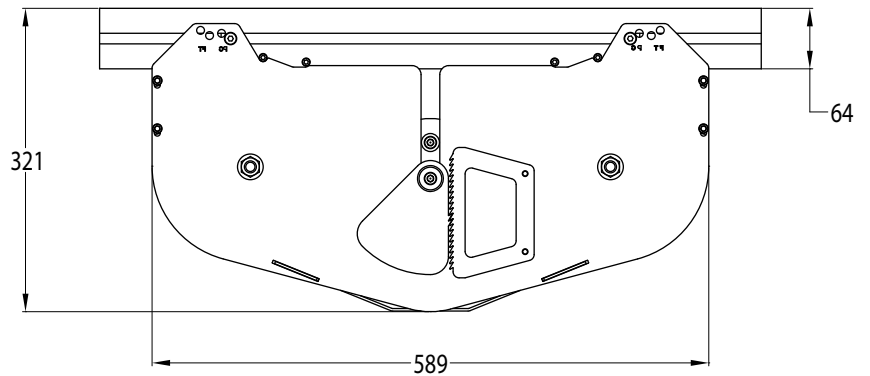

FS Weighted Take-up Tail Module

FS-WTU_065

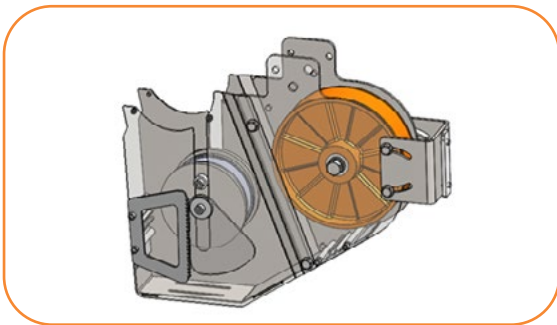

- Provides controlled chain take-up for improved conveyor performance
- Compact design fits in similar space as standard direct drive modules
- Smooths conveyor chain movement by helping to eliminate micro-surfing
- Suggested for conveyors over 12.2 M (40 ft) in length
- Capable of inclined and declined arrangement up to 30 degrees
- Improves operator safety by enclosing chain catenary
- Attaches to direct end drive tail
- Compatible with power transfer and driven bridge

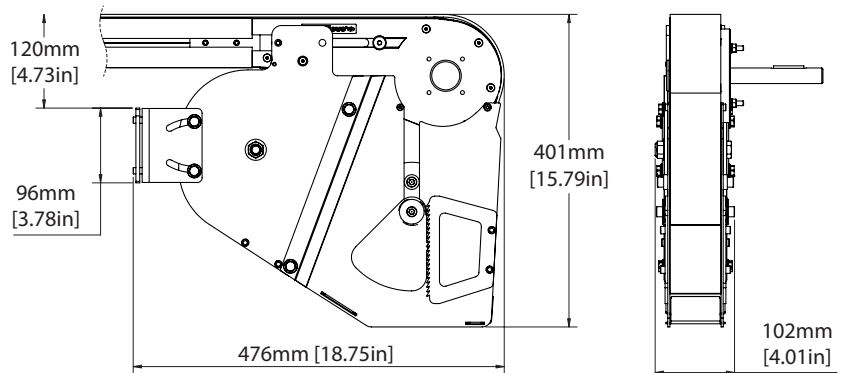
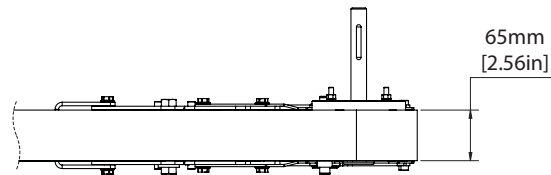

UOM: pc
Chain required 1.5 meter
Slide rail required 2.1 meter

FS Top Running Drive Module

FSTRD-203

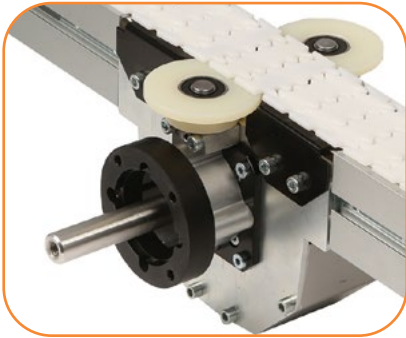

- For top running chain only
- 9M long conveyor length maximum
- 32 Kg load maximum
- Compatible with 3/4 inch shaft gearmotors only

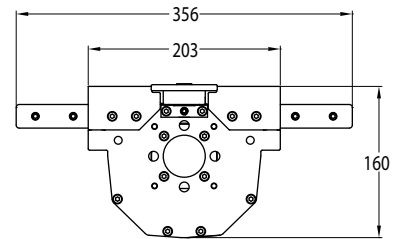
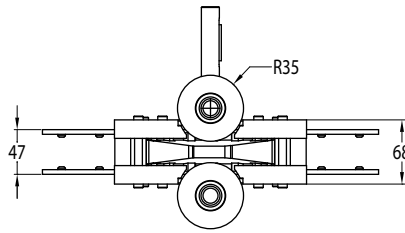
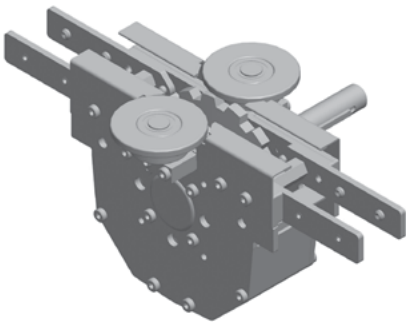

UOM: pc

Chain required 0.2 meter

FS Direct Wheel Drive with Motor

FSWD-DD-0M

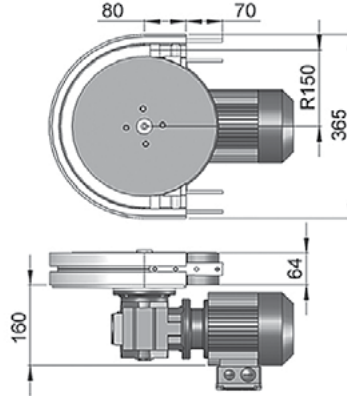
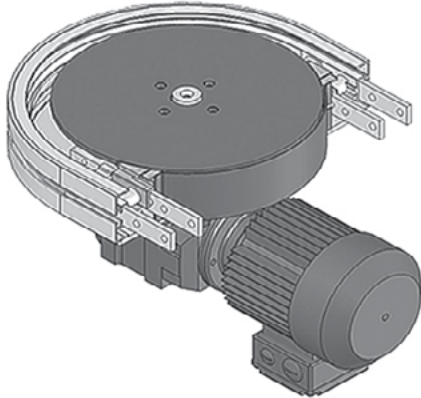

Max Traction Force: 200N

The Direct Wheel Drive Unit is without torque limiter. FSWD-DD-0M represents direct drive without gear motor. Maximum traction force for FSWD-DD is lower than FSDD and FSSD.

UOM: pc

Chain required 1-way: 0.7 meter
Slide rail required 1-way: 0.7 meter

FS Suspended Wheel Drive without Motor

FSWD-SD-0M

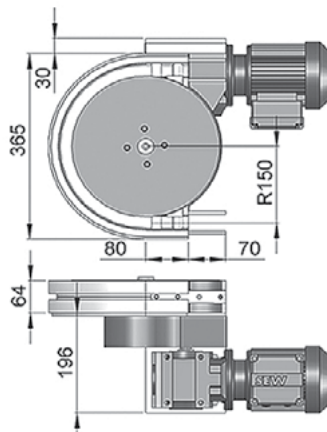
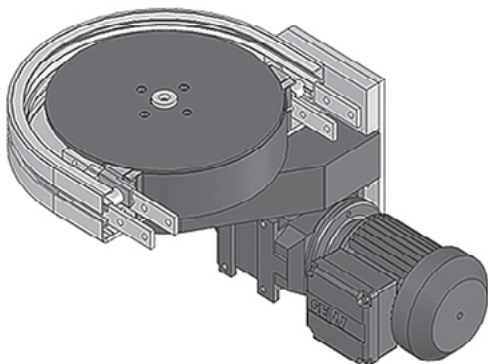

Max Traction Force: 200N

The Suspended Wheel Drive Unit is with torque limiter. FSWD-SD-0M represents direct drive without gear motor. Maximum traction force for FSWD-SD is lower than FSDD and FSSD.

UOM: pc

Chain required 1-way: 0.7 meter
Slide rail required 1-way: 0.7 meter

FS Idler End-65

FSIE-A65

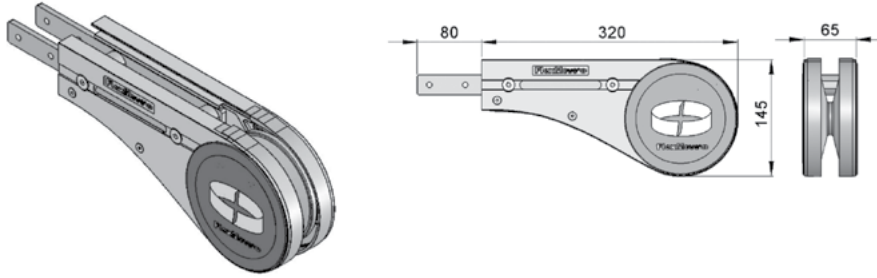

UOM: pc
 Chain required 2-way: 0.8 meter
 Slide rail required 2-way: 0.5 meter

FS Idler End with Power Transfer (LEFT)

FSIE-A65PT-L

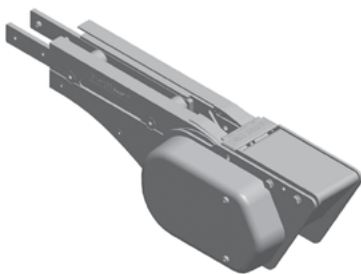

UOM: pc

Minimum product length for inline transfer = 100 mm
 Provides extended transfer nose for interfacing with large rollers.

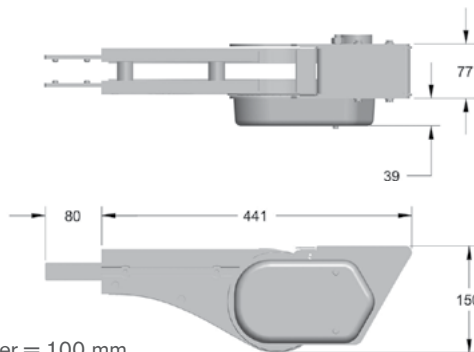

FS Idler End with Power Transfer (RIGHT)

FSIE-A65PT-R

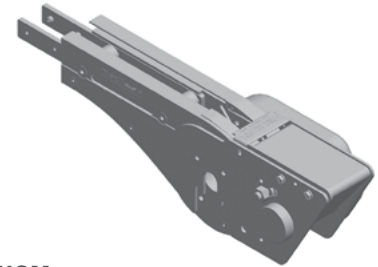

UOM: pc
 Chain required 2-way: 0.8 meter
 Slide rail required 2-way: 0.5 meter

FS Idler End Driven Transfer Bridge (LEFT)

FSIE-A65DB-A-L

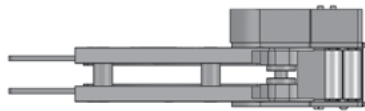

Minimum product length for inline transfer = 100 mm
 Transfer extends past conveyor only 27 mm

UOM: pc

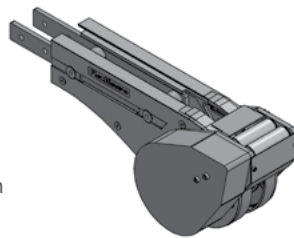

FS Direct Drive Driven Transfer Bridge (RIGHT)

FSIE-A65DB-A-R

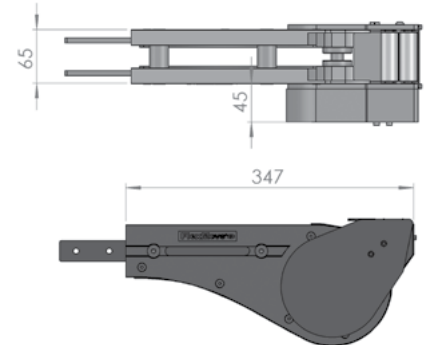

FS Idler Free Roller Transfer Bridge

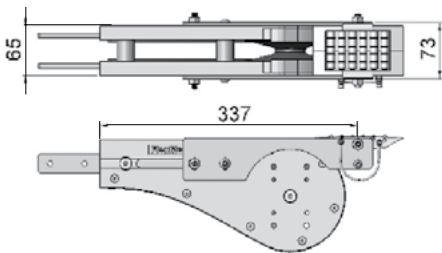

Roller transfer bridge is sold separately.

FSTB-A65

Transfer bridge c/w roller for FSIE-A65, FSDD-A65-XDY and FSDD-A65GP-XDY

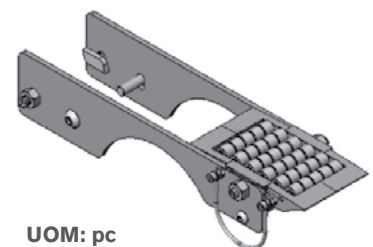

UOM: pc
 SEW gearmotors are products of SEW Eurodrive

FS Idler End Free Roller Bridge

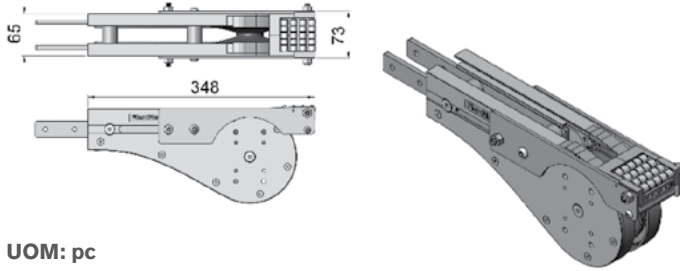

UOM: pc

FSEB-A65

End transfer bridge c/w roller for FSIE-A65, FSDD-A65-XDY and FSDD-A65GP-XDY

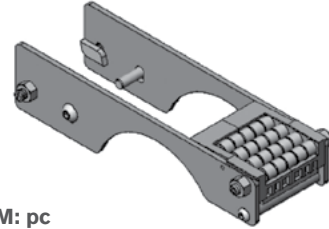

UOM: pc

FS Idler End-200

FSIE-200

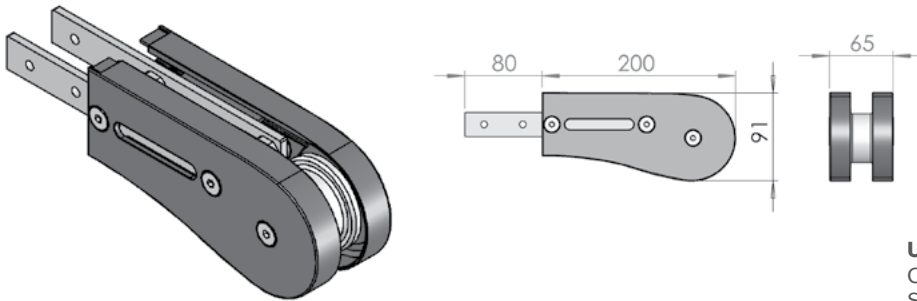

UOM: pc

Chain required 2-way: 0.7 meter
Slide rail required 2-way: 0

FS Idler-200 End Free Roller Bridge

Roller transfer bridge is sold separately.

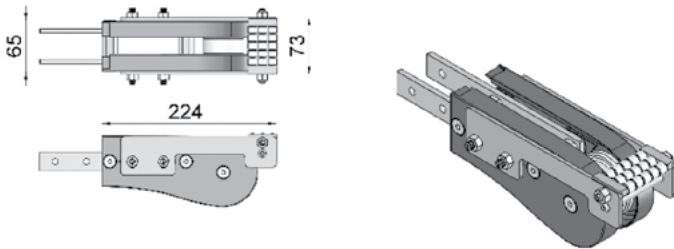

FSEB-A65-200

End transfer bridge c/w roller for FSIE-200

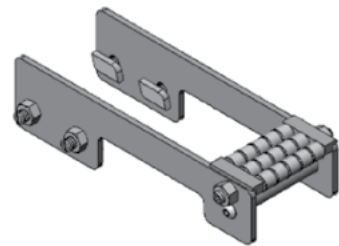

UOM: pc

FS Idler Bend FSIB-206

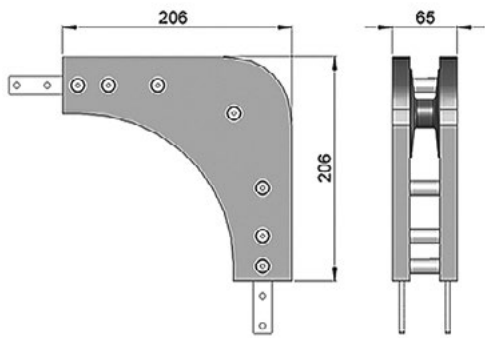

UOM: pc
 Chain required 1-way: 0.6 meter
 Slide rail: 0 meter
Note: Cannot be used with return chain

FS Wheel Bend 180° FSWB-180R150A

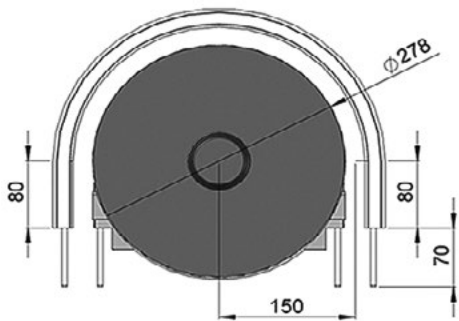
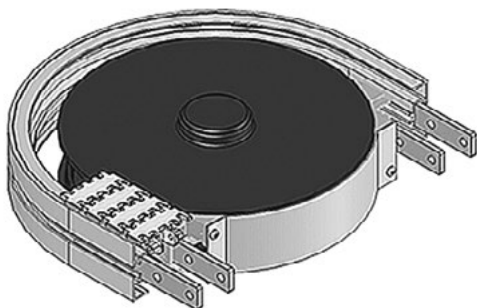

UOM: pc
 Chain required 2-way: 1.3 meter
 Slide rail required 2-way: 1.3 meter

FS Wheel Bend 90° FSWB-90R150A

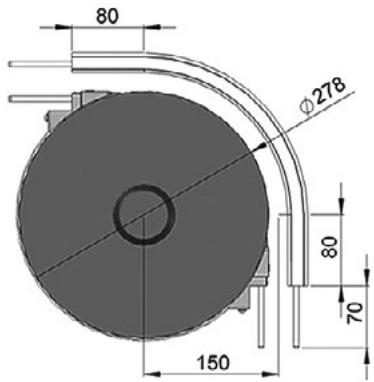

UOM: pc
 Chain required 2-way: 0.8 meter
 Slide rail required 2-way: 0.8 meter

FS Wheel Bend 60° FSWB-60R150A

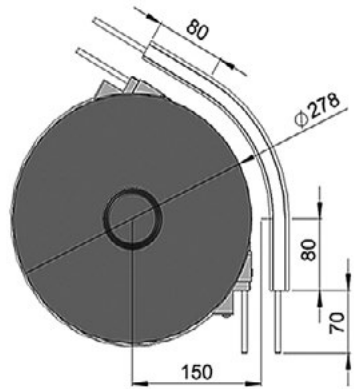
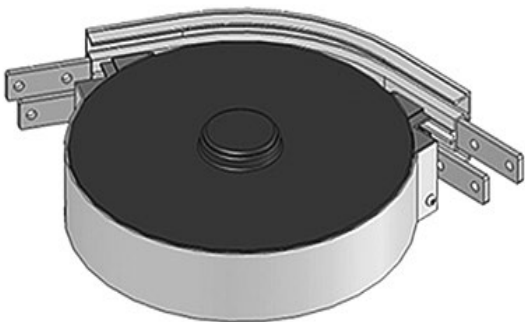

UOM: pc
 Chain required 2-way: 0.6 meter
 Slide rail required 2-way: 0.6 meter

FS Wheel Bend 45°

FSWB-45R150A

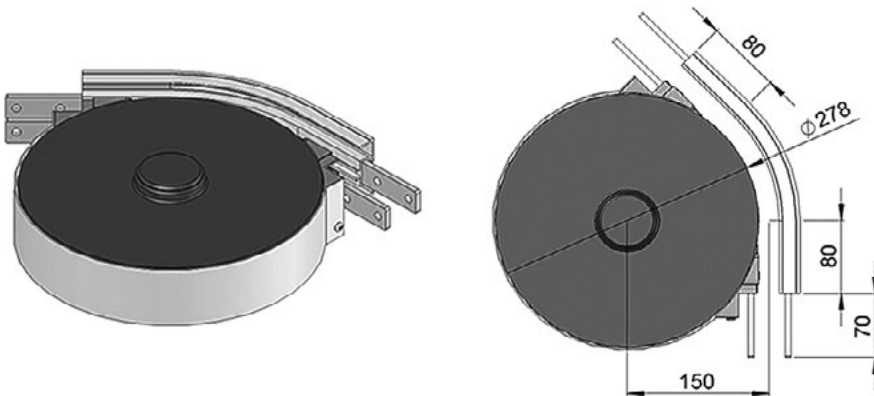

UOM: pc

Chain required 2-way: 0.6 meter
Slide rail required 2-way: 0.6 meter

FS Wheel Bend 30°

FSWB-30R150A

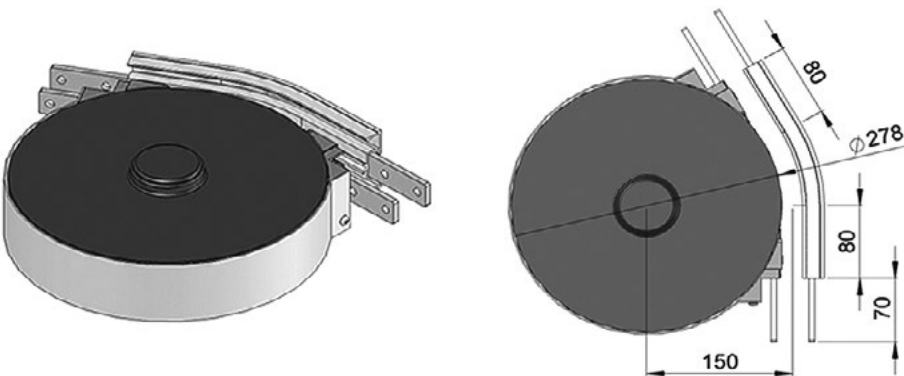

UOM: pc

Chain required 2-way: 0.5 meter
Slide rail required 2-way: 0.5 meter

FS Wheel Bend 5° - 180°

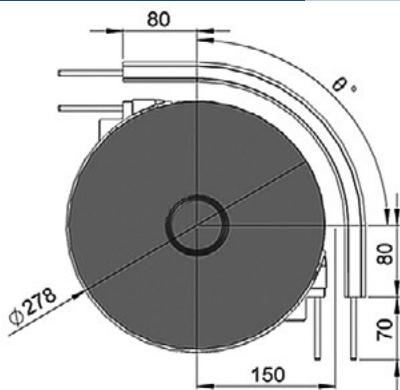

Example for FS Wheel Bend Ordering

- Wheel bend, $\varnothing^\circ \pm 1^\circ$
- FSWB- \varnothing° R150A

If an angle of 65° is needed for wheel bend, the ordering part number is

FSWB-65R150A

The outer bend is assembled using connecting strip (FACS-25x140A). Angle of \varnothing° must be indicated when ordering.

FS Horizontal Plain Bend 15°

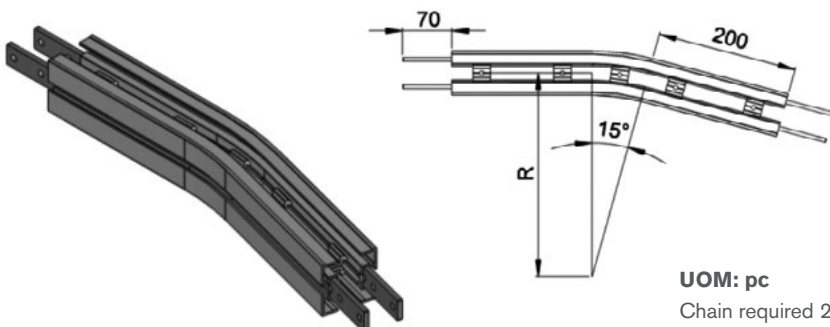

Horizontal plain bend, 15° ± 1°

R = 300 ± 10 mm	FSHB-15R300
R = 500 ± 10 mm	FSHB-15R500
R = 700 ± 10 mm	FSHB-15R700
R = 1000 ± 10 mm	FSHB-15R1000

UOM: pc

Chain required 2-way (300, 500, 700, 1000): 1, 1.1, 1.2, 1.3 meter
Slide rail required 2-way (300, 500, 700, 1000): 1.9, 2.1, 2.3, 2.6 meter

FS Horizontal Plain Bend 30°

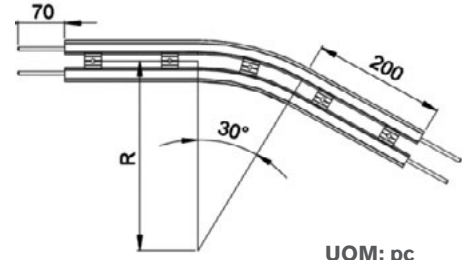

Horizontal plain bend, 30° ± 1°

R = 300 ± 10 mm	FSHB-30R300
R = 500 ± 10 mm	FSHB-30R500
R = 700 ± 10 mm	FSHB-30R700
R = 1000 ± 10 mm	FSHB-30R1000

UOM: pc
 Chain required 2-way (300, 500, 700, 1000): 1.1, 1.3, 1.5, 1.8 meter
 Slide rail required 2-way (300, 500, 700, 1000): 2.2, 2.6, 3.1, 3.7 meter

FS Horizontal Plain Bend 45°

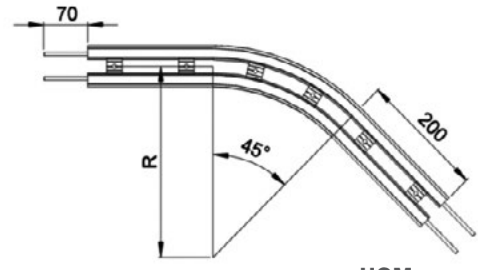

Horizontal plain bend, 45° ± 1°

R = 300 ± 10 mm	FSHB-45R300
R = 500 ± 10 mm	FSHB-45R500
R = 700 ± 10 mm	FSHB-45R700
R = 1000 ± 10 mm	FSHB-45R1000

UOM: pc
 Chain required 2-way (300, 500, 700, 1000): 1.3, 1.6, 1.9, 2.4 meter
 Slide rail required 2-way (300, 500, 700, 1000): 2.5, 3.2, 3.8, 4.7 meter

FS Horizontal Plain Bend 60°

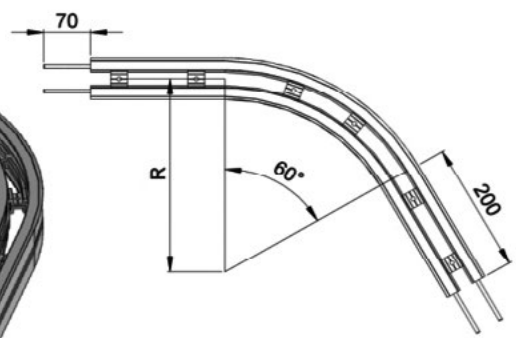
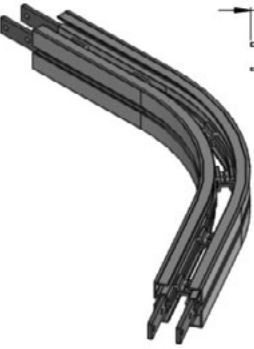

Horizontal plain bend, 60° ± 1°

R = 300 ± 10 mm	FSHB-60R300
R = 500 ± 10 mm	FSHB-60R500
R = 700 ± 10 mm	FSHB-60R700
R = 1000 ± 10 mm	FSHB-60R1000

UOM: pc
 Chain required 2-way (300, 500, 700, 1000): 1.4, 1.8, 2.3, 2.9 meter
 Slide rail required 2-way (300, 500, 700, 1000): 2.9, 3.7, 4.5, 5.8 meter

FS Horizontal Plain Bend 90°

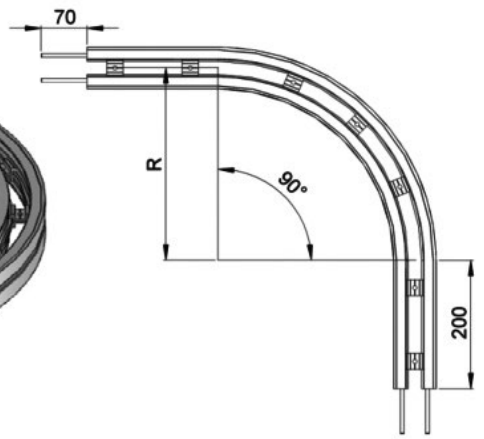

Horizontal plain bend, 90° ± 1°

R = 300 ± 10 mm	FSHB-90R300
R = 500 ± 10 mm	FSHB-90R500
R = 700 ± 10 mm	FSHB-90R700
R = 1000 ± 10 mm	FSHB-90R1000

UOM: pc
 Chain required 2-way (300, 500, 700, 1000): 1.7, 2.4, 3.0, 3.9 meter
 Slide rail required 2-way (300, 500, 700, 1000): 3.5, 4.7, 6.0, 7.9 meter

FS Horizontal Plain Bend 180°

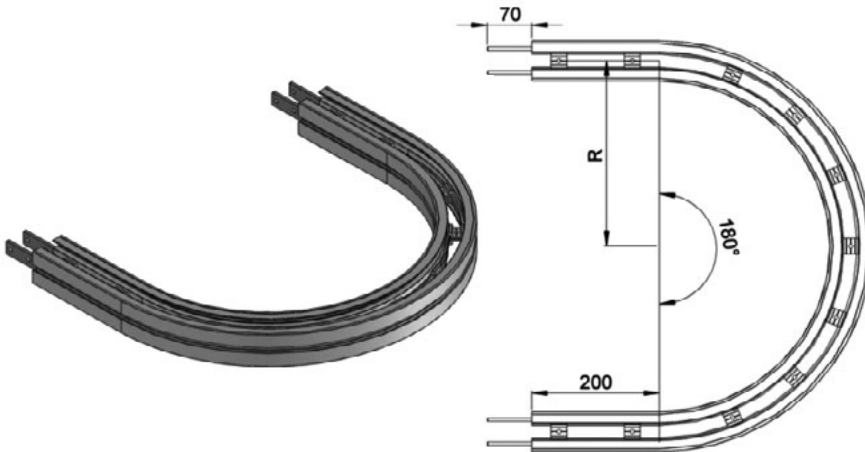

Horizontal plain bend, 180° ± 1°

R = 300 ± 10 mm	FSHB-180R300
R = 500 ± 10 mm	FSHB-180R500
R = 700 ± 10 mm	FSHB-180R700
R = 1000 ± 10 mm	FSHB-180R1000

UOM: pc

Chain required 2-way (300, 500, 700, 1000): 2.7, 3.9, 5.2, 7.1 meter

Slide rail required 2-way (300, 500, 700, 1000): 5.4, 7.9, 10.4, 14.2 meter

FS Horizontal Plain Bend 5° - 180°

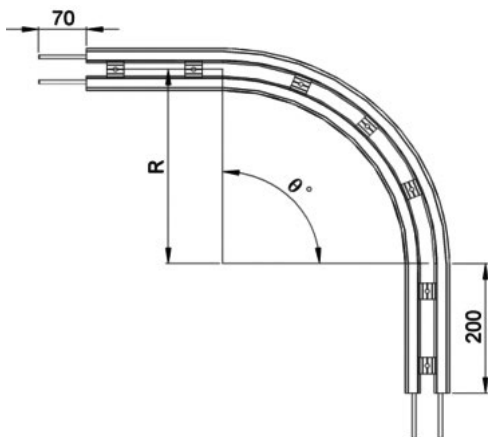

Example for FS Horizontal Plain Bend Ordering

Horizontal plain bend, θ° ± 1°

R = 300 ± 10 mm	FSHB- θ°300
R = 500 ± 10 mm	FSHB- θ°500
R = 700 ± 10 mm	FSHB- θ°700
R = 1000 ± 10 mm	FSHB- θ°1000

If an angle of 120° is needed for radius R500 horizontal plain bend, the ordering part number is

FSHB-120R500

UOM: pc

Chain required 2-way (300, 500, 700, 1000): meter (Variable to angle)

Slide rail required 2-way (300, 500, 700, 1000): meter (Variable to angle)

FS Vertical Bend 5°

FSVB-5R300

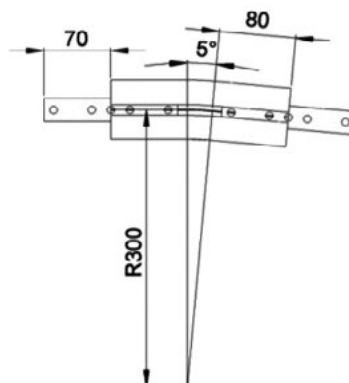
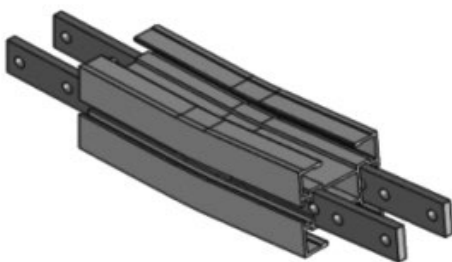

UOM: pc

Chain required 2-way: 0.4 meter

Slide rail required 2-way: 0.7 meter

FS Vertical Bend 10°

FSVB-10R300

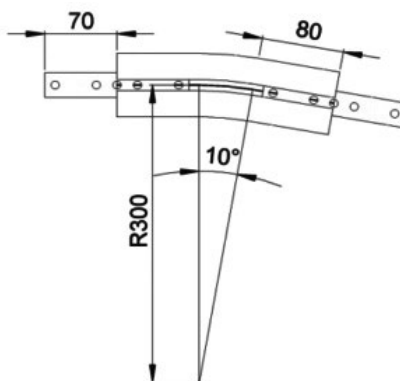

UOM: pc

Chain required 2-way: 0.4 meter
Slide rail required 2-way: 0.8 meter

FS Vertical Bend 15°

FSVB-15R300

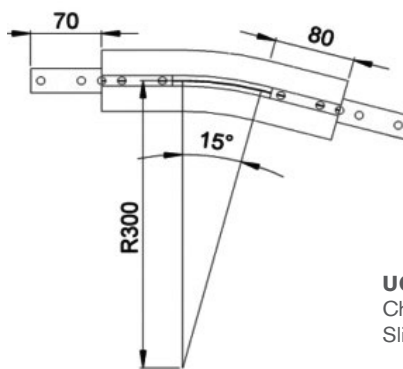
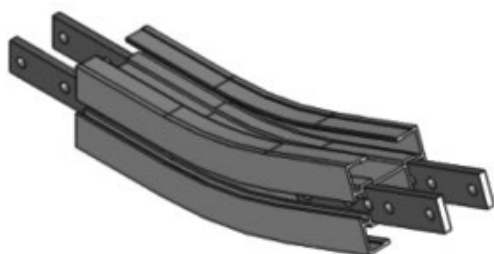

UOM: pc

Chain required 2-way: 0.5 meter
Slide rail required 2-way: 1.0 meter

FS Vertical Bend 20°

FSVB-20R300

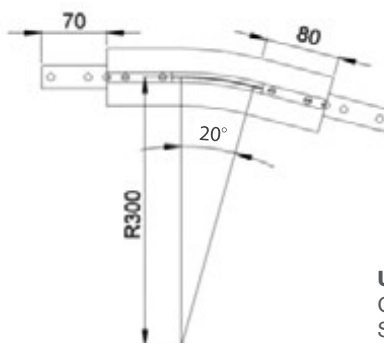
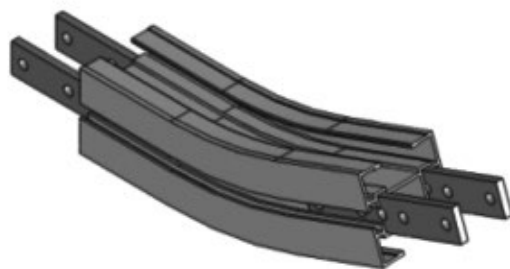

UOM: pc

Chain required 2-way: 0.5 meter
Slide rail required 2-way: 1.1 meter

FS Vertical Bend 30°

FSVB-30R300

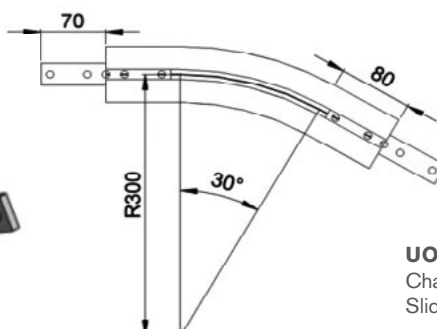
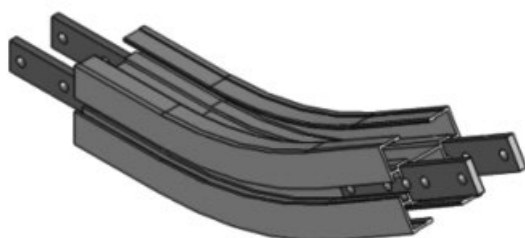

UOM: pc

Chain required 2-way: 0.6 meter
Slide rail required 2-way: 1.3 meter

FS Vertical Bend 45°

FSVB-45R300

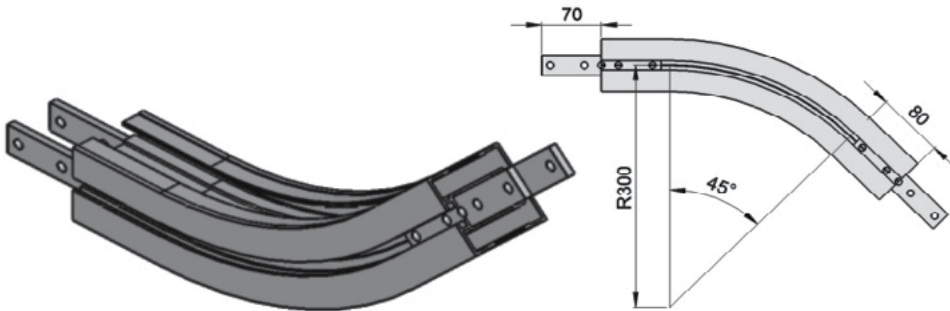

UOM: pc

Chain required 2-way: 0.8 meter
Slide rail required 2-way: 1.6 meter

FS Vertical Bend 60°

FSVB-60R300

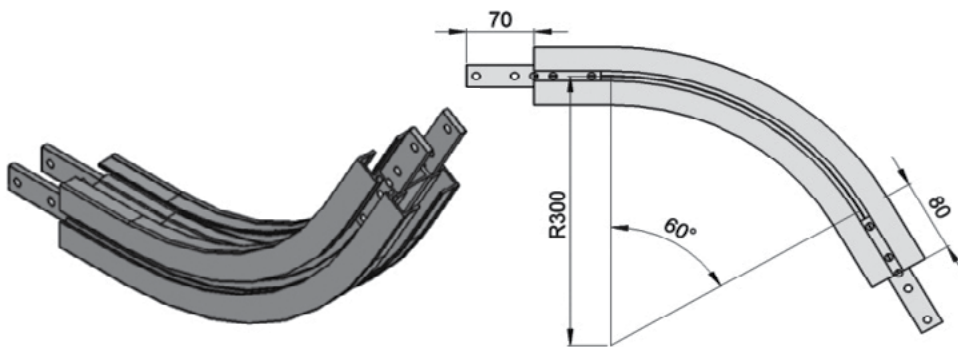

UOM: pc

Chain required 2-way: 0.9 meter
Slide rail required 2-way: 1.9 meter

FS Vertical Bend 90°

FSVB-90R300

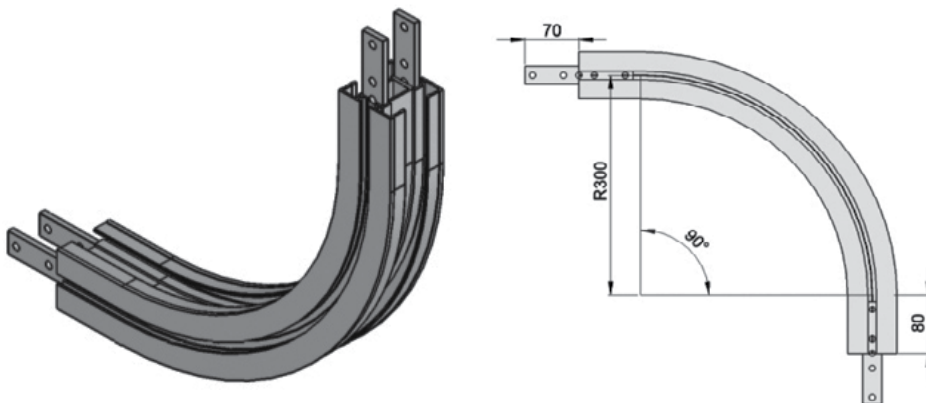

UOM: pc

Chain required 2-way: 1.3 meter
Slide rail required 2-way: 2.5 meter

FS Vertical Bend 5° - 90°

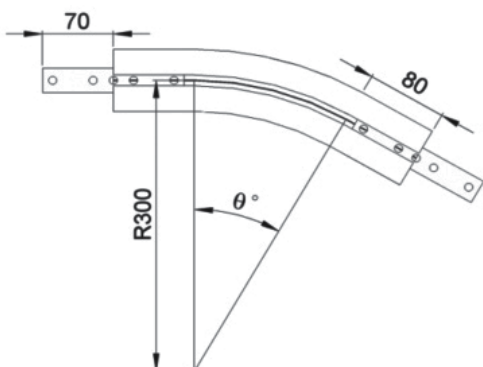

Example for FS Vertical Bend Ordering

- Vertical bend, $\varnothing^\circ \pm 1^\circ$
- FSVB- \varnothing° R300

If an angle of 65° is needed for vertical bend,
the ordering part number is

FSVB-65R300

The outer bend is assembled using connecting strip (FACS-25x140A). Angle of \varnothing° must be indicated when ordering.

FS 45 Degree Twist Conveyor Beam (Clockwise)

FSTB-CW45x3000

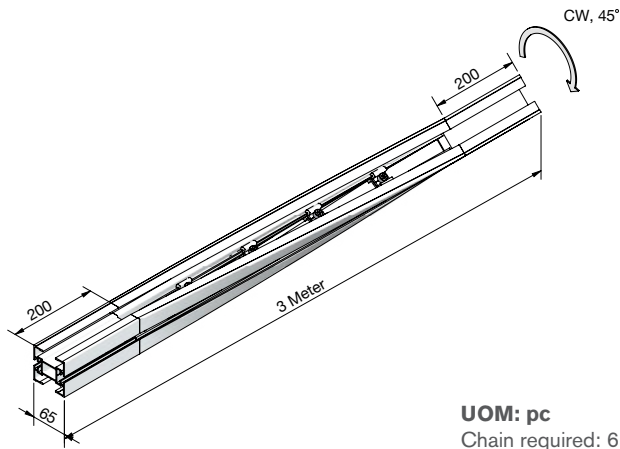

UOM: pc
Chain required: 6 meter
Slide rail required: 12 meter

FS 45 Degree Twist Conveyor Beam (Counter-Clockwise)

FSTB-CCW45x3000

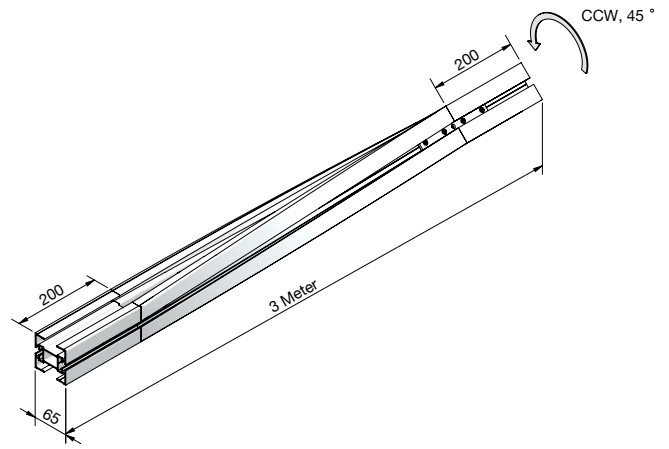

FS 90 Degree Twist Conveyor Beam (Clockwise)

FSTB-CW90x3000

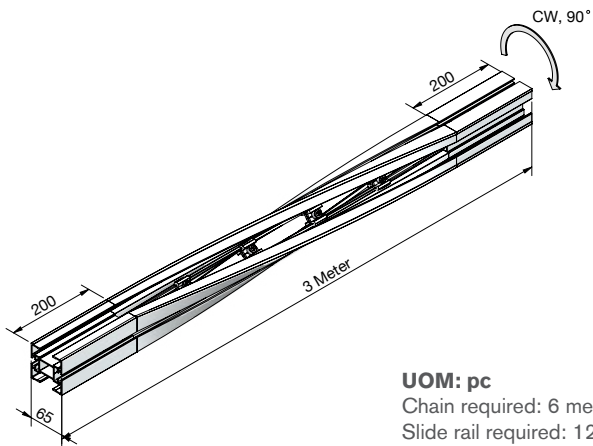

UOM: pc
Chain required: 6 meter
Slide rail required: 12 meter

FS 90 Degree Twist Conveyor Beam (Counter-Clockwise)

FSTB-CCW90x3000

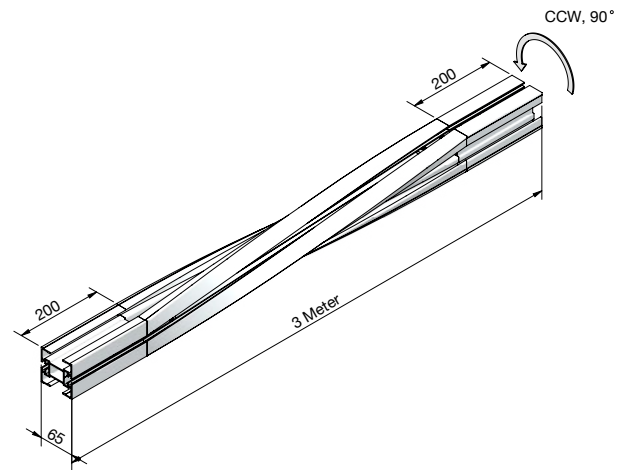

FS Twist Conveyor Beam 15° - 90°

FSTB-AAABBx3000

Where AAA = CW or CCW, BB = Angle

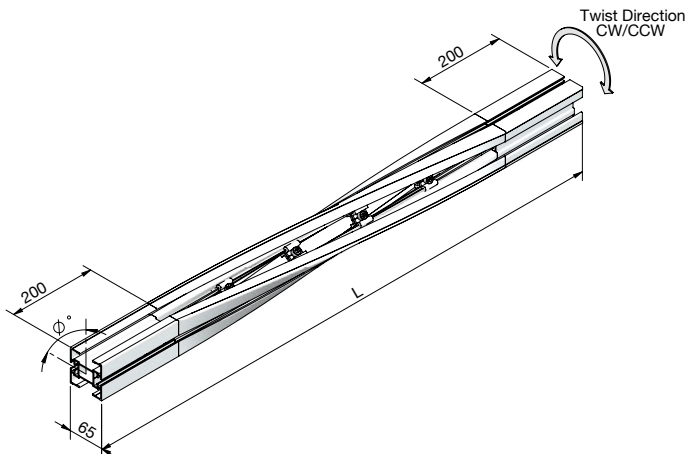

Example for FS Twist Conveyor Beam Ordering

- Twist Conveyor Beam, $\emptyset^\circ \pm 5^\circ$

If an angle of 30° is needed for twist beam, in clockwise direction and length 3.0 m, the ordering part number is

FSTB-CW30x3000

Angle of \emptyset° , twist direction, and length L , must be indicated when ordering.

UOM: pc
Chain required: 6 meter
Slide rail required: 12 meter

FS X In-Line Transfer Module

FSST-065

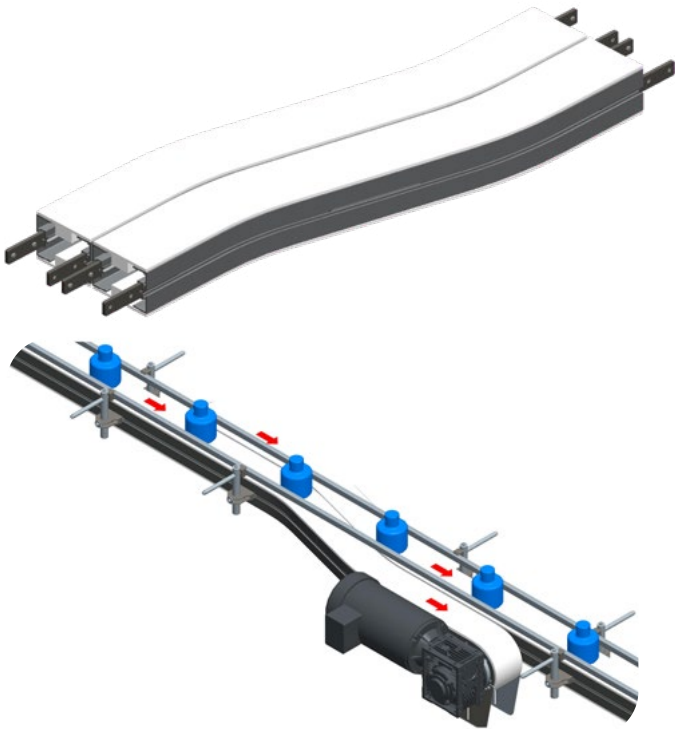

- S In-Line Modules provide a standard, compact way to side transfer product from conveyor to conveyor.
- Straight guiding is placed across the transfer module for smooth In-Line product flow
- Conveyors are mounted together to provide a smooth transfer even for small products
- S In-Line transfers are compact in the width dimension

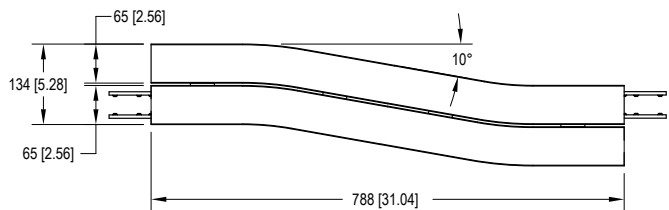

FS S In-Line Transfer Module

FSXT-065



- X In-Line Modules provide a standard, compact way to side transfer product from conveyor to conveyor.
- Straight guiding is placed across the transfer module for smooth In-Line product flow
- Conveyors are mounted together to provide a smooth transfer even for small products
- X In-Line transfers are compact in the length direction

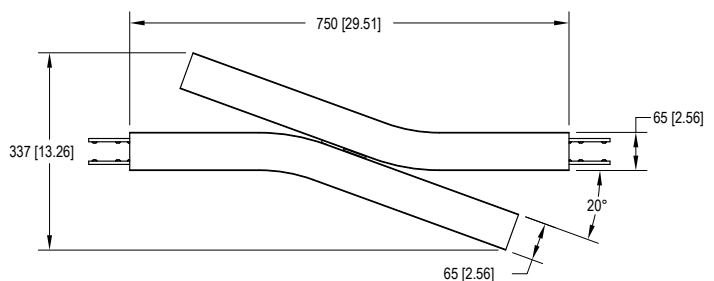

Variety of chain type suitable for wide range of applications either horizontal or vertical product transportation. Higher capacity than FK and FS. The maximum product width to be conveyed can be referred to guide rail assembly pages.

FM Series Characteristic

Beam Width: 85 mm

Product Width: Refer to Guide Rail Assembly

Accessories Needed

Slide Rail Required: FASR-25 OR FASR-25U

Slide Rail Color: White or Natural Color

Slide Rail Material: HDPE OR UHMW-PE

Slide Rail Rivet & Screw: FASLR-4X6 or FASLS-M5

Connecting strip is used to connect two beams.

Connecting Strip: FACS-25x140A

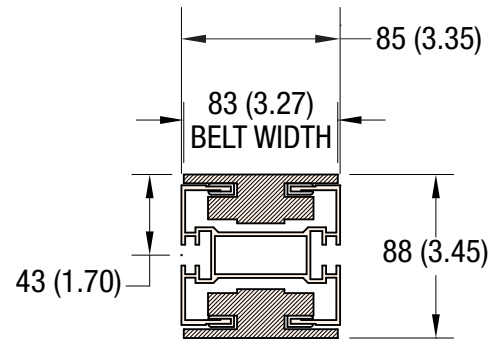

85 MM WIDTH

Conveyor Beam FMCB-3

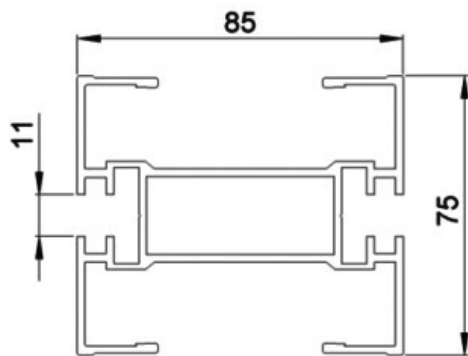

UOM: 3 Meter / Length

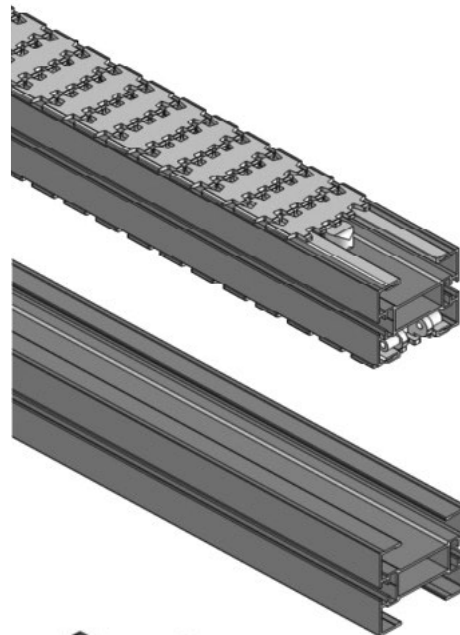

Chain Connecting Module FMCC-160

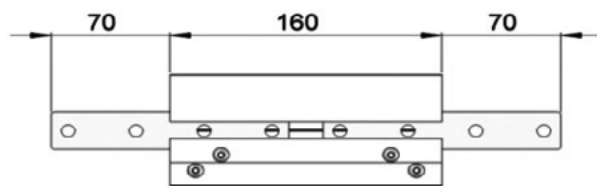

UOM: pc

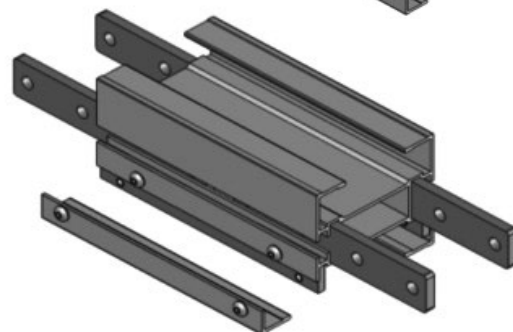

Chain Common Data

Packaging: 5 m per box

Pitch: 33.5 mm

Width: 83 mm

Tensile Strength at 20°C: 6000N

Color: White & Black (Conductive)

Material:

Chain: White Acetal / POM

Pivot: Polyamide

Pivot Pin: Stainless Steel

Insert (Wedge & Friction): TPE Grey

Example for FMCT-5A17-L#

= 1 cleated top chain with alternate of # link of plain chain

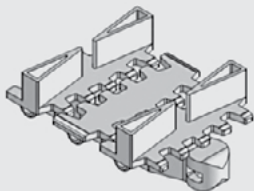

The above chain is FMCT-5A17-L1, 1 link cleated top chain with alternate of 1 link of plain chain.

Note: # = 1, 2, 3, 4, 5.....20

Standard Plain Chain FMPC-5

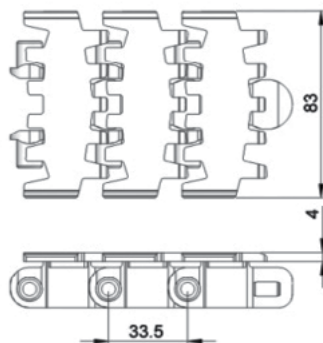
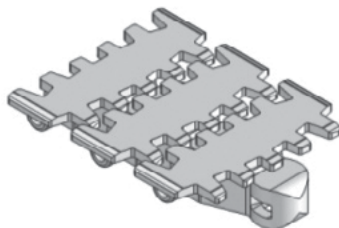

UOM: 5 Meter / box

Application: Suitable for horizontal and slope < 5° transport of products with accumulation.

Conductive Chain FMPC-5CD

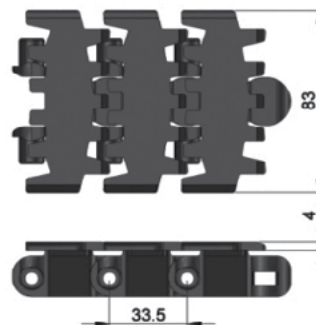
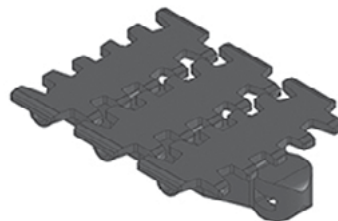

UOM: 5 Meter / box

Application: Suitable for transport of static sensitive product.

Twist Chain FMPC-5M

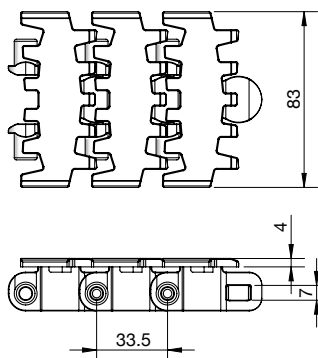
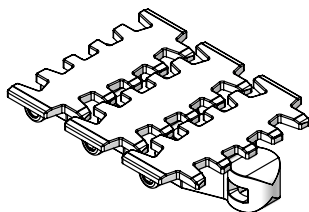

UOM: 5 Meter / box

Application: Suitable twist conveyor beam; horizontal and slope < 5° transport of products with accumulation

Safety Chain FMPC-5V

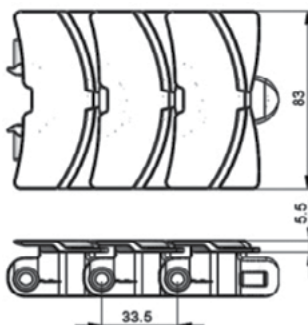
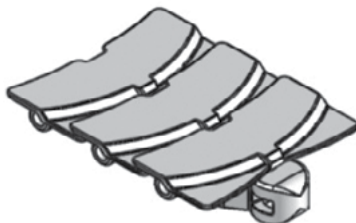

UOM: 5 Meter / box

Application: (Safety Chain) Suitable for horizontal and slope < 5° transport of products with accumulation

Safety Chain Friction Top FMFT-5V-A

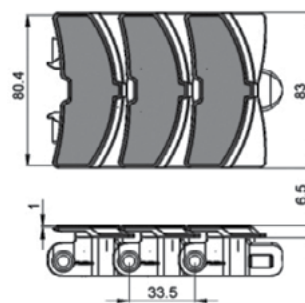

UOM: 5 Meter / box

Application: (Safety Chain) Suitable for transport product in slope > 5° but ≤ 30° without accumulation.

Friction Top Chain **FMFT-5**

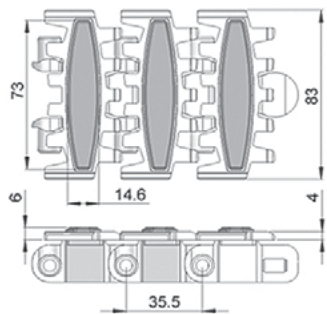
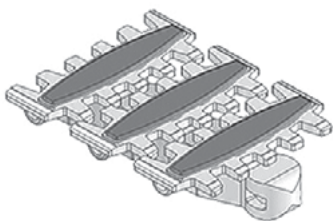

UOM: 5 Meter / box

Application: Suitable for transport product in slope $> 5^\circ$ but $\leq 30^\circ$ without accumulation.

Friction Top Chain **FMFT-5A**

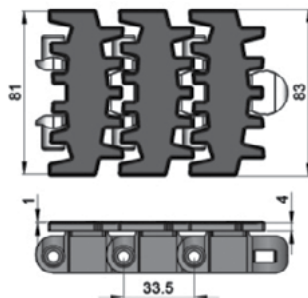
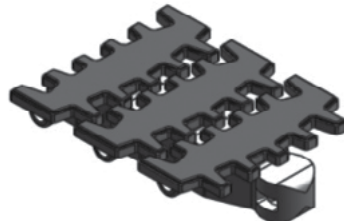

UOM: 5 Meter / box

Application: Suitable for transport product in slope $> 5^\circ$ but $\leq 30^\circ$ without accumulation.

Wedge Top Chain **FMWT-5A**

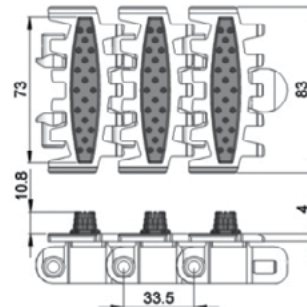
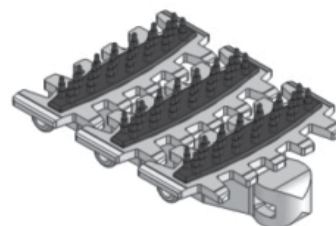

UOM: 5 Meter / box

Application: Vertical Wedge transportation of products.

Wedge Top Chain **FMWT-5B**

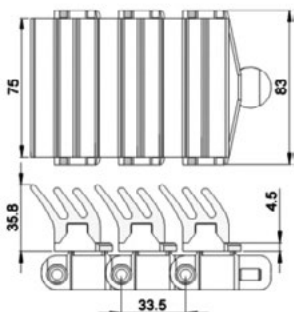
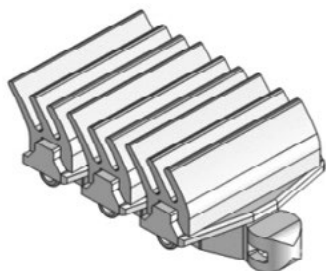

UOM: 5 Meter / box

Application: Vertical Wedge transportation of products (Heavy Duty)

Wedge Top Chain **FMWT-5C**

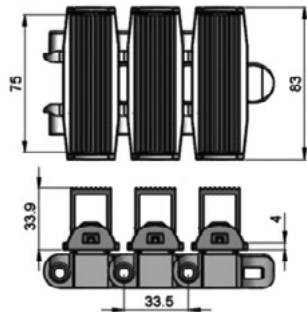
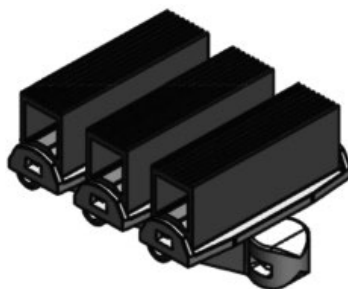

UOM: 5 Meter / box

Application: Vertical Wedge transportation of products (Heavy Duty)

Wedge Top Chain **FMWT-5D**

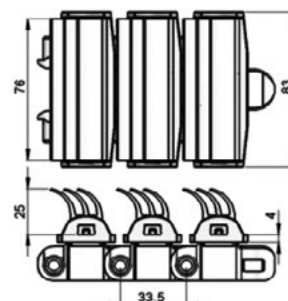
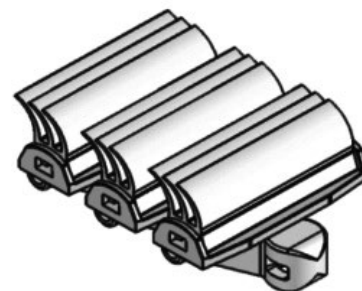

UOM: 5 Meter / box

Application: Vertical Wedge transportation of products.

Magnet Top Chain **FMMT-5**

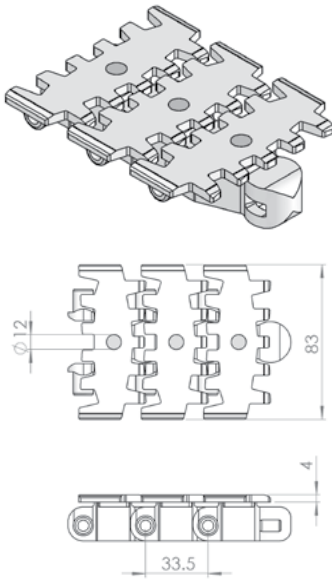

UOM: 5 Meter / box

Application: Suitable for conveying of ferromagnetic products in slope.

Magnet Top Chain **FMMT-5-L#**

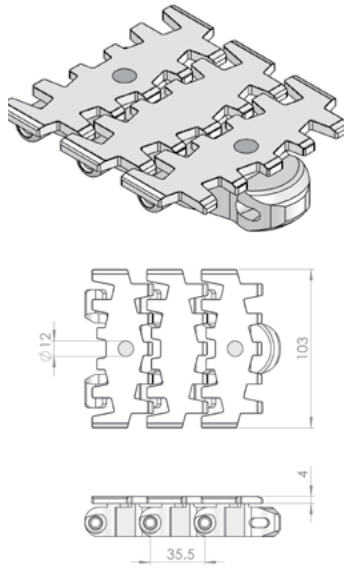

UOM: 5 Meter / box

Application: Suitable for conveying of ferromagnetic products in slope.

Flocked Chain **FMFK-5**

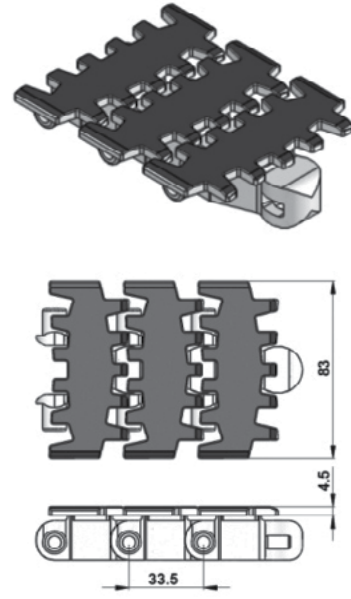

UOM: 5 Meter / box

Application: Suitable to transport lightweight, fragile and scratch sensitive product.

Stainless Steel Top Chain **FMST-5S**

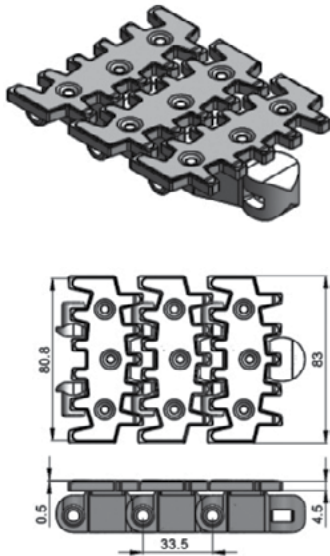

UOM: 5 Meter / box

Application: Suitable to transport metal products in accumulation.

Universal Chain **FMUC-5**

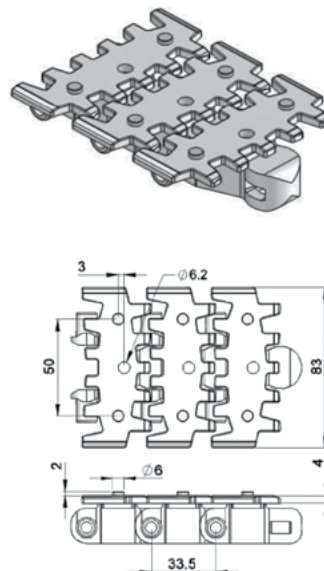

UOM: 5 Meter / box

Application: Universal Link with M6 Nut, Suitable for attached customer cleat or fixture.

Roller Top Chain **FMRT-5**

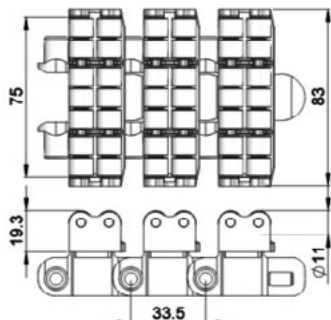
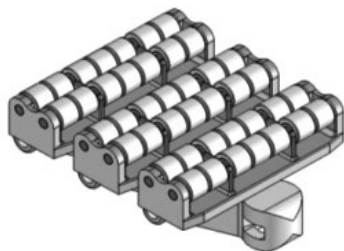

UOM: 5 Meter / box

Application: Suitable for accumulation of product with low friction and pressure.

Roller Cleat Chain **FMRC-5A-L#**

= 1, 2, 3, 4, 5.....20

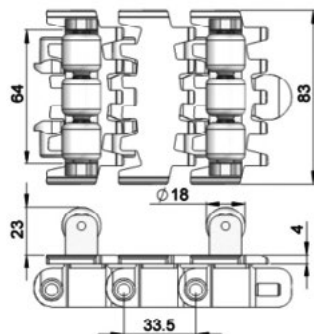
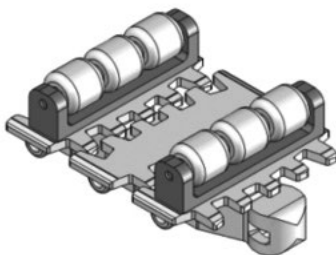

UOM: 5 Meter / box

Application: Suitable for vertical transportation of product in slope with no accumulation.

Roller Cleat Chain **FMRC-5B-L#**

= 1, 2, 3, 4, 5.....20

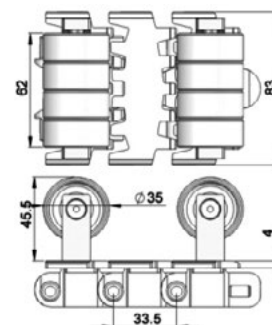
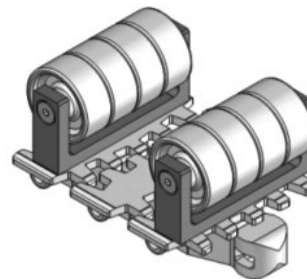

UOM: 5 Meter / box

Application: Suitable for vertical transportation of product in slope with no accumulation.

Cleat Top Chain **FMCT-5A17-L#**

= 1, 2, 3, 4, 5.....20

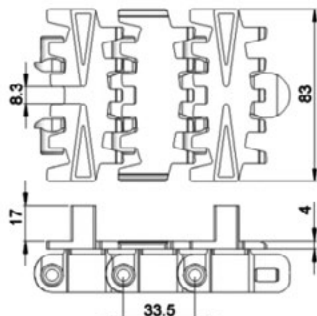
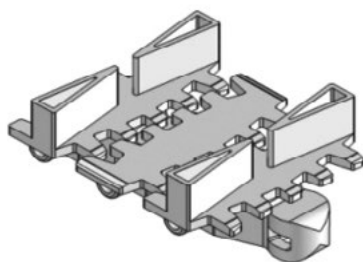

UOM: 5 Meter / box

Application: Suitable for vertical transport of product with no accumulation.

Cleat Top Chain **FMCT-5A30-L#**

= 1, 2, 3, 4, 5.....20

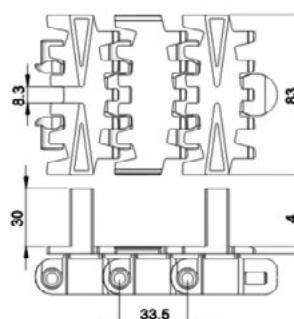
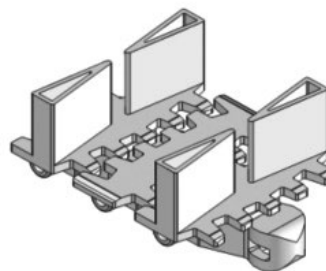

UOM: 5 Meter / box

Application: Suitable for vertical transport of product with no accumulation.

Safety Chain with rollers **FMPC-5VR**

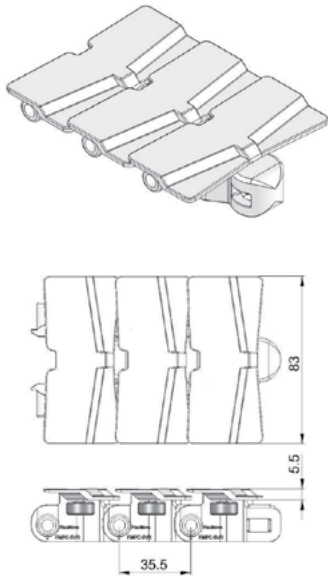

UOM: 5 Meter / box

Application: Suitable for transport product in slope $> 5^\circ$ but $\leq 30^\circ$ without accumulation. (Subject to product weight and Packing)

Safety Chain Friction Top with rollers **FMFT-5VR-A**

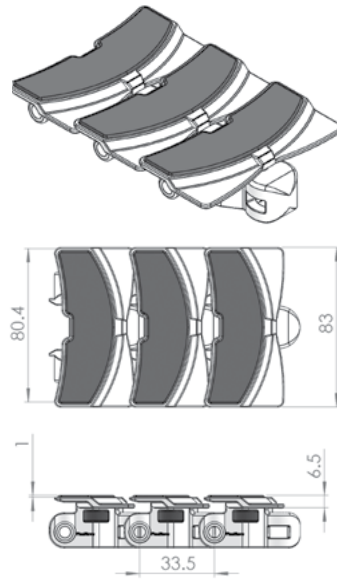

UOM: 5 Meter / box

Application: Suitable for transport product in slope $> 5^\circ$ but $\leq 30^\circ$ without accumulation. (Subject to product weight and Packing)

Plain Chain with rollers **FMPC-5R**

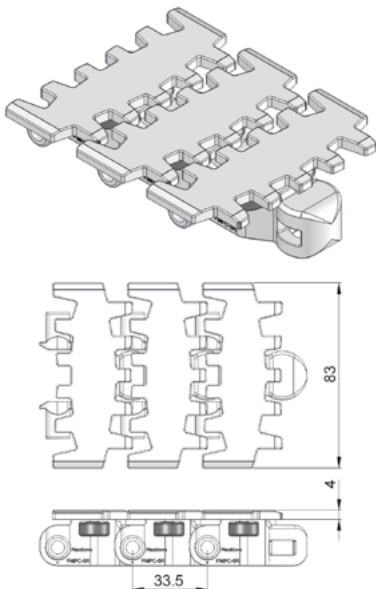

UOM: 5 Meter / box

Application: Suitable for horizontal and slope $< 5^\circ$ transport of products with accumulation.

Friction Top Chain **FMFT-5C**

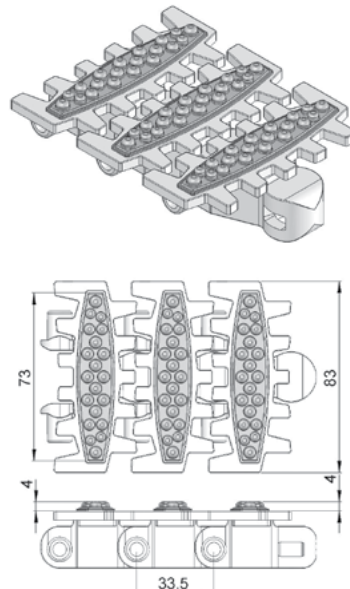

UOM: 5 Meter / box

Application: Suitable for transport product in slope $> 5^\circ$ but $\leq 35^\circ$ without accumulation. (Subject to product weight and Packing)

FM Direct End Drive without Motor (LEFT)

FMDD-A85-XDY (See Chart)

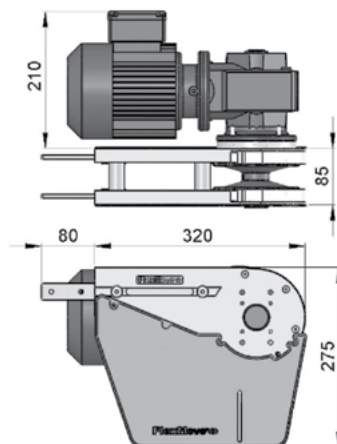
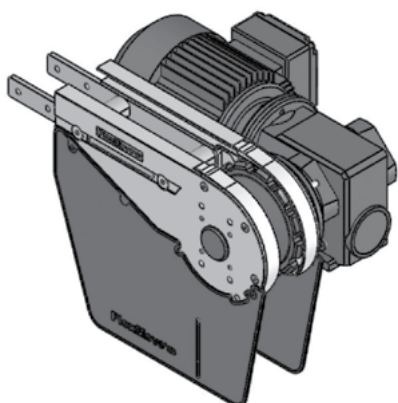

FM Direct End Drive without Motor (RIGHT)

FMDD-A85-XDY (See Chart)

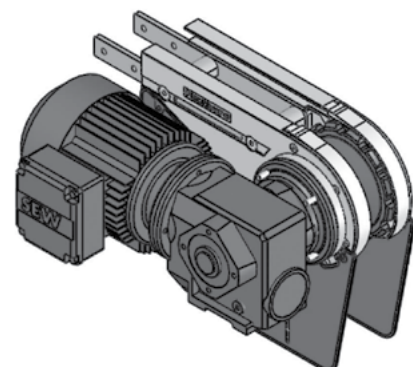

Part Number		Shaft Selection	Direction	Aux Shaft Selection
FMDD-A85	-	X	D	Y
		0 = 20 mm	L = Left	Blank = No Aux Shaft
		E = 3/4 in*	R = Right	A = 20 mm Aux Shaft
		A = 20 mm Aux Only		

*3/4 inch shaft option available in North America only.

Max Traction Force: 1250N

The Direct End Drive Unit is without torque limiter.

UOM: pc

Chain required 2-way: 0.8 meter
Slide rail required 2-way: 0.5 meter

FM Direct End Drive without Motor GP (LEFT)

FMDD-A85GP-XDY (See Chart)

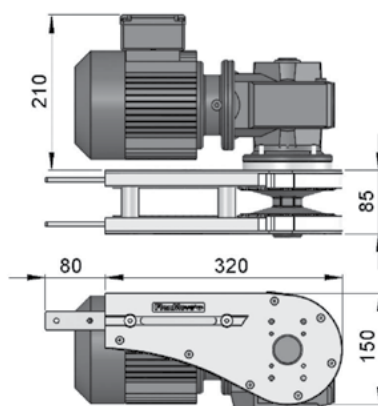
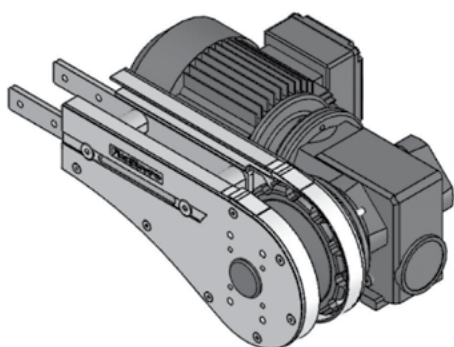

FM Direct End Drive without Motor GP (RIGHT)

FMDD-A85GP-XDY (See Chart)

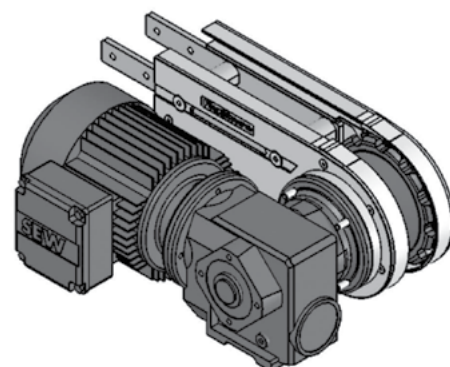

Requires the use of connecting or weighted take-up module for chain maintenance.

Part Number		Shaft Selection	Direction	Aux Shaft Selection
FMDD-A85GP	-	X	D	Y
		0 = 20 mm	L = Left	Blank = No Aux Shaft
		E = 3/4 in*	R = Right	A = 20 mm Aux Shaft
		A = 20 mm Aux Only		

*3/4 inch shaft option available in North America only.

Max Traction Force: 1250N

The Direct End Drive Unit GP is without torque limiter.

UOM: pc

Chain required 2-way: 0.8 meter
Slide rail required 2-way: 0.5 meter

SEW gearmotors are products of SEW Eurodrive

FM Direct with Power Transfer Motor (LEFT)

FMDD-A85PT-XD (See Chart)

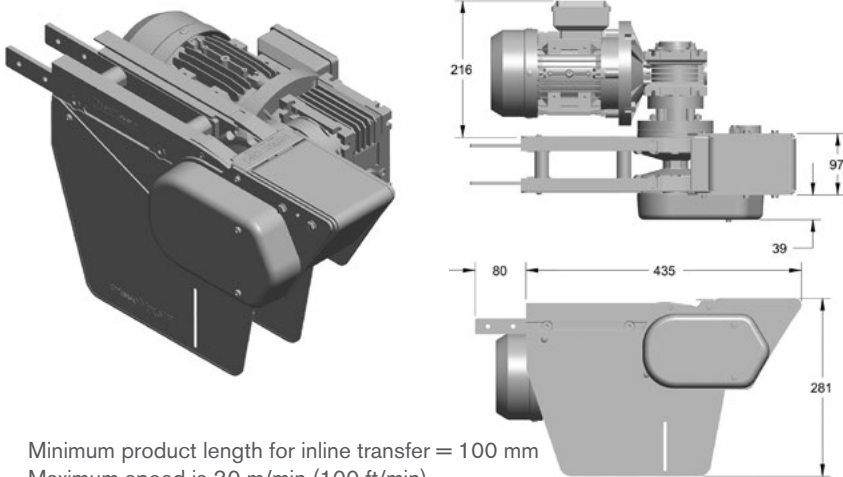

Minimum product length for inline transfer = 100 mm
 Maximum speed is 30 m/min (100 ft/min)
 Only one power transfer needed on either infeed or discharge trail required for end to end transfer.
 Provides extended transfer nose for interfacing with large rollers.

Part Number		Shaft Selection	Direction
FMDD-A85PT	-	X	D
		0 = 20 mm	L = Left
		E = 3/4 in*	R = Right

*3/4 inch shaft option available in North America only.

FM Direct with Power Transfer Motor (RIGHT)

FMDD-A85PT-XD (See Chart)

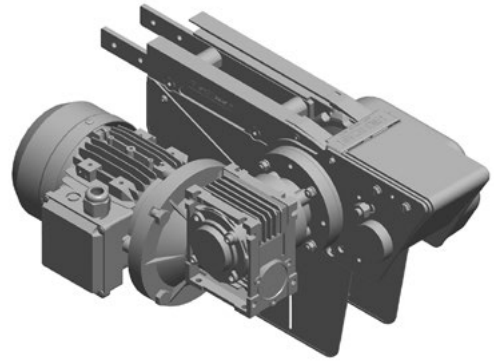

Max Traction Force: 1250N
 The Direct End Drive Unit is without torque limiter.

UOM: pc
 Chain required 2-way: 0.8 meter
 Slide rail required 2-way: 0.5 meter

FM GP Direct with Power Transfer Motor (LEFT)

FMDD-A85GPPT-XD (See Chart)

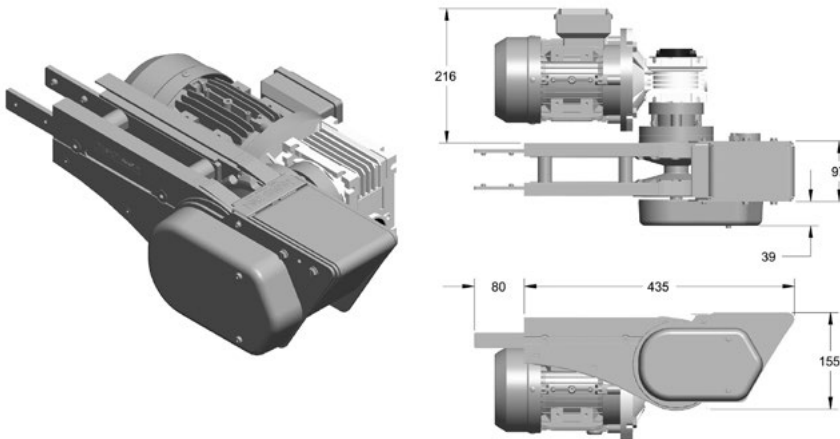

Minimum product length for inline transfer = 100 mm
 Maximum speed is 30 m/min (100 ft/min)
 Only one power transfer needed on either infeed or discharge trail required for end to end transfer. Provides extended transfer nose for interfacing with large rollers.
 Requires the use of connecting or weighted take-up module for chain maintenance.

Part Number		Shaft Selection	Direction
FMDD-A85GPPT	-	X	D
		0 = 20 mm	L = Left
		E = 3/4 in*	R = Right

*3/4 inch shaft option available in North America only.

FM GP Direct with Power Transfer Motor (RIGHT)

FMDD-A85GPPT-XD (See Chart)

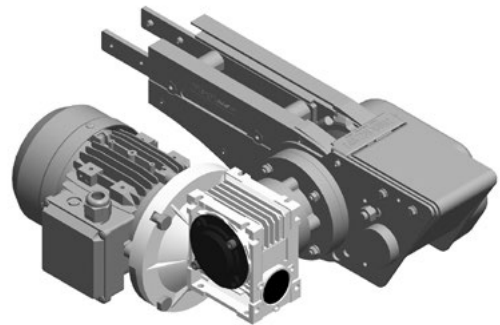

Max Traction Force: 1250N
 The Direct End Drive Unit GP is without torque limiter.

UOM: pc
 Chain required 2-way: 0.8 meter
 Slide rail required 2-way: 0.5 meter

SEW gearmotors are products of SEW Eurodrive

FM Direct Drive Driven Transfer Bridge (LEFT)

FMDD-A85DB-A-0L

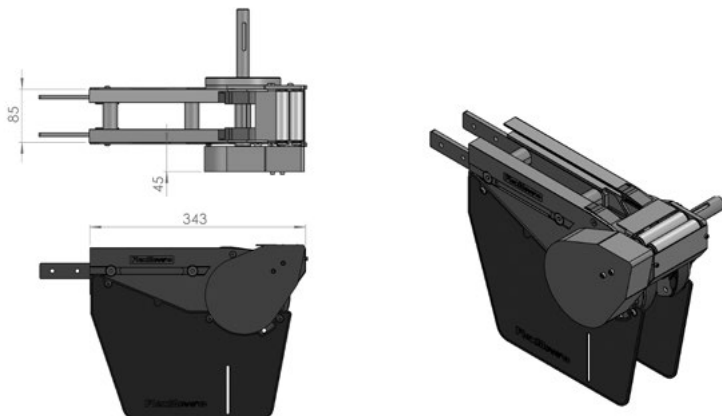

20 mm Shaft only.
 Minimum product length for inline transfer = 100 mm
 Transfer extends past conveyor only 27 mm

FM Direct Drive Driven Transfer Bridge (RIGHT)

FSIE-A65DB-A-R

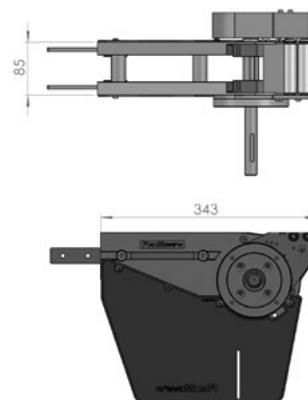

UOM: Unit
 Chain required 2-way: 0.8 meter
 Slide rail required 2-way: 0.5 meter

FM Direct Drive Free Roller Transfer Bridge (LEFT/ RIGHT)

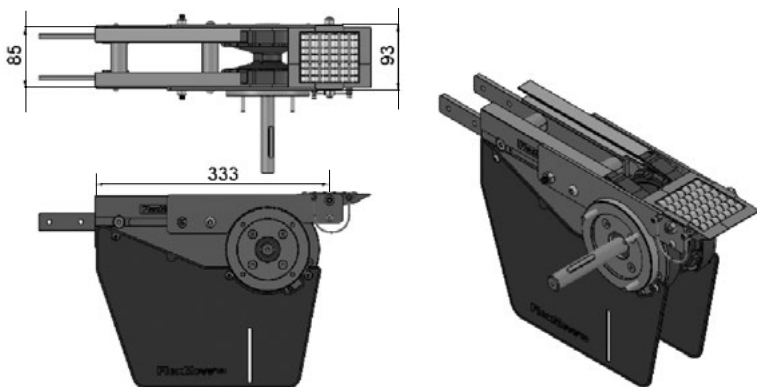

UOM: pc

FMTB-A85

Transfer bridge c/w roller for FMIE-A85
 Transfer bridge c/w roller for FMDD-A85-0L
 Transfer bridge c/w roller for FMDD-A85-0R

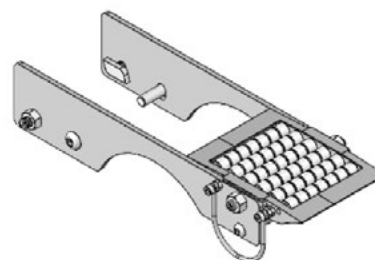

UOM: pc

FM Direct Drive End Free Roller Bridge (LEFT/ RIGHT)

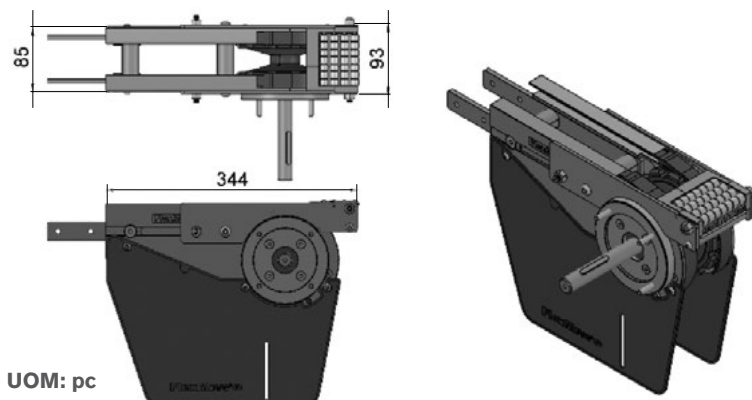

UOM: pc

FMEB-A85

End transfer bridge c/w roller for FMIE-A85
 End transfer bridge c/w roller for FMDD-A85-0L
 End transfer bridge c/w roller for FMDD-A85-0R

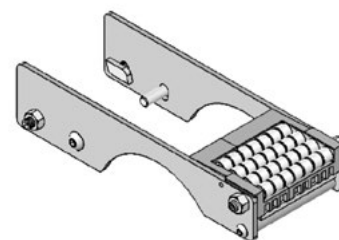

UOM: pc

FM Suspended End Drive without Motor (LEFT)

FMSD-A85-0L (with Torque Limiter)
FMSD-A85SPT-0L (without Torque Limiter)

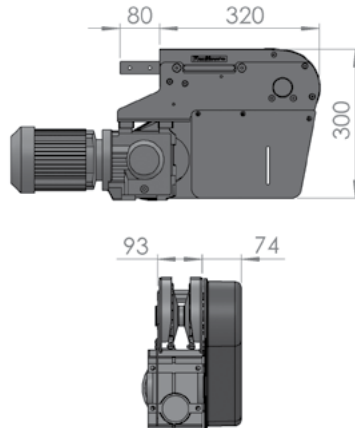
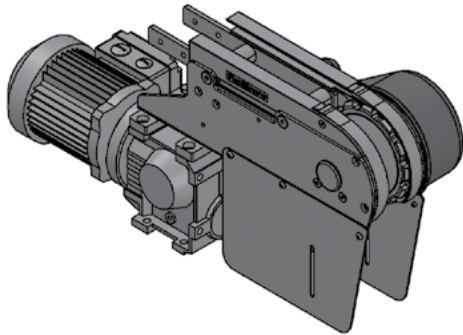

- Locates gearmotor below conveyor for compact applications.
- Includes torque limiter protecting chain and motor from overload.
- Chain pull capacity at 1250N for unit without torque limiter.
- Chain pull capacity at 840N for unit with torque limiter.

FM Suspended End Drive without Motor (RIGHT)

FMSD-A85-OR (with Torque Limiter)
FMSD-A85SPT-OR (without Torque Limiter)

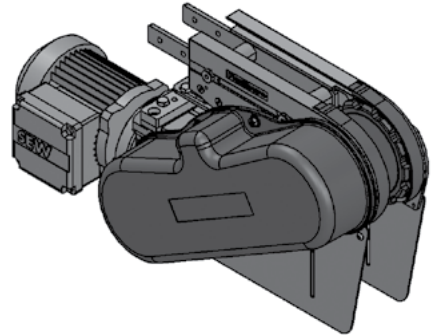

Max Traction Force:

1250N (without limiter)

840N (with limiter)

UOM: pc

Chain required 2-way: 0.8 meter

Slide rail required 2-way: 0.5 meter

FM Direct Intermediate Drive without Motor (LEFT)

FMID-DD-0L1

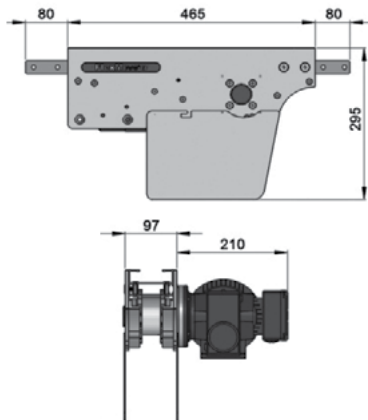
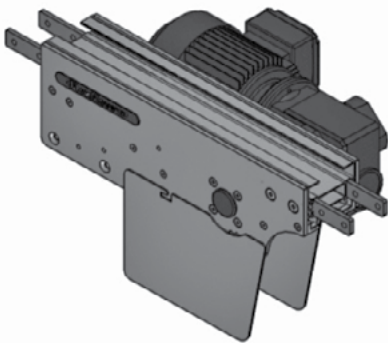

- Located in middle of conveyor to free up drive end.
- Includes torque limiter protecting chain and motor from overload.
- Limits chain pull capacity at 200N.

FM Direct Intermediate Drive without Motor (RIGHT)

FMID-DD-0R1

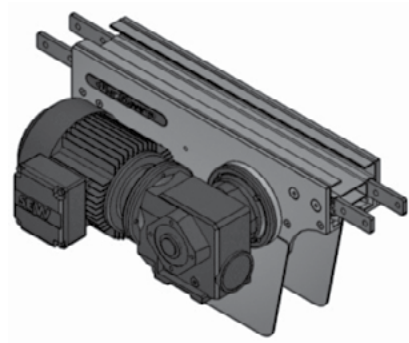

Max Traction Force: 200N

The Direct Intermediate Drive Unit is without torque limiter.

UOM: pc

Chain required 2-way: 1.2 meter

Slide rail required 2-way: 1.1 meter

SEW gearmotors are products of SEW Eurodrive

FM Suspended Intermediate Drive without Motor (LEFT)

FMID-SD-0L1

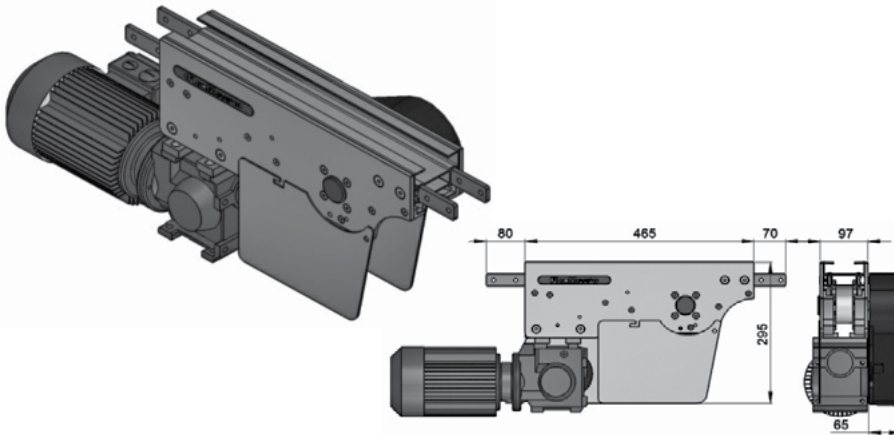

- Located in middle of conveyor to free up drive end.
- Includes torque limiter protecting chain and motor form overload.
- Limits chain pull capacity at 200N.

FM Suspended Intermediate Drive without Motor (RIGHT)

FMID-SD-0R1

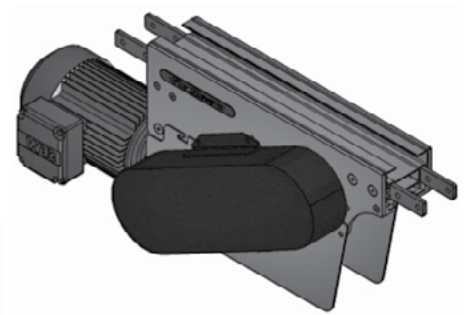

Max Traction Force: 200N

The Suspended Intermediate Drive Unit is with torque limiter.

UOM: pc

Chain required 2-way: 1.2 meter
Slide rail required 2-way: 1.1 meter

FM Combined Direct Drive & Idler (LEFT)

FMCDI-DD-A85

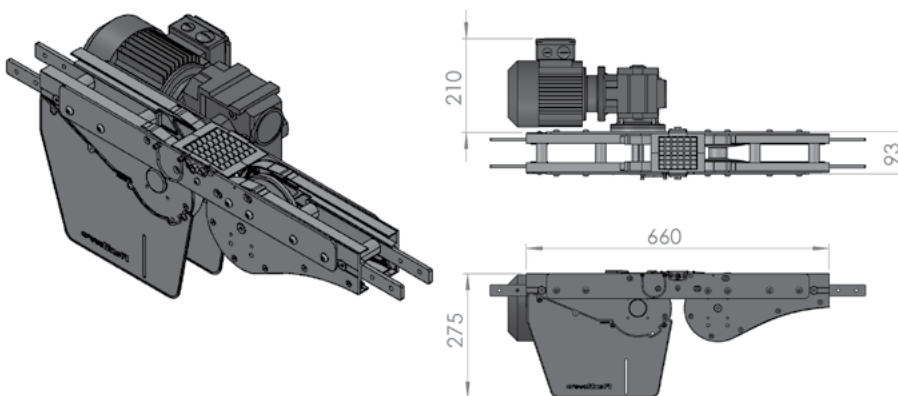

FM Combined Direct Drive & Idler (RIGHT)

FMCDI-DD-A85

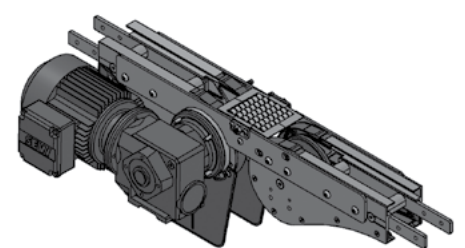

Max Traction Force: 1250N

The Combine Direct End Drive Unit is without torque limiter.

UOM: pc

Chain required 2-way: 1.6 meter
Slide rail required 2-way: 1.0 meter

SEW gearmotors are products of SEW Eurodrive

FM Combined Suspended Drive & Idler (LEFT)

FMCDI-SD-A85

FM Combined Suspended Drive & Idler (RIGHT)

FMCDI-SD-A85

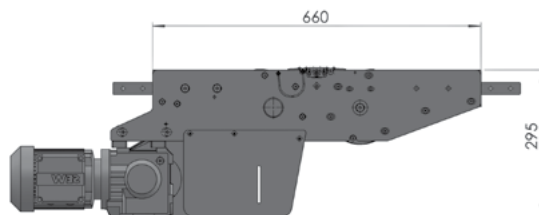
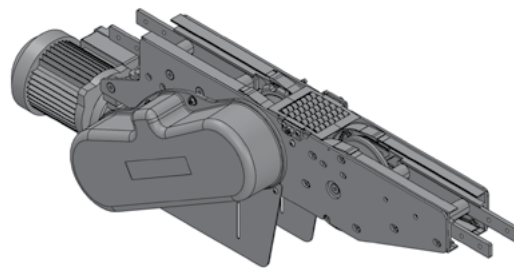
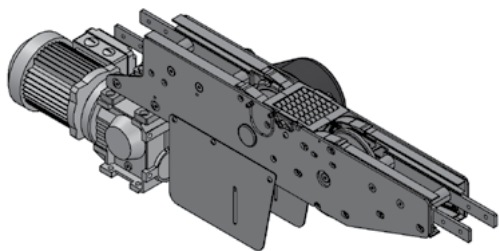

Max Traction Force: 840N

The Combine Suspended End Drive Unit is with torque limiter.

UOM: pc

Chain required 2-way: 1.6 meter
Slide rail required 2-way: 1.0 meter

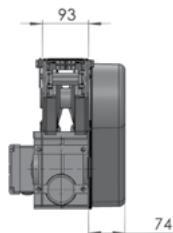

FM Suspended Catenary Drive without Motor (LEFT)

FMCD-SD

FM Suspended Catenary Drive without Motor (RIGHT)

FMCD-SD

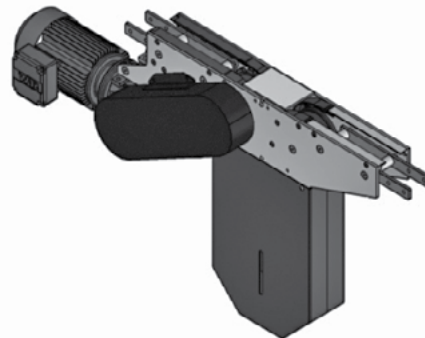
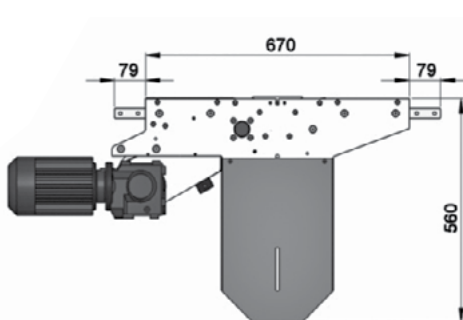
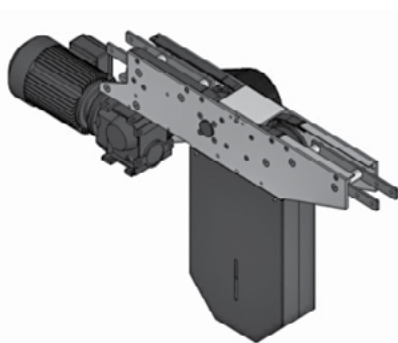

Max Traction Force: 840N

The Suspended Catenary Drive Unit is with torque limiter.

UOM: pc

Chain required 1-way: 1.4 meter
Slide rail required 1-way: 1.0 meter

SEW gearmotors are products of SEW Eurodrive

FM Weighted Take-up Module

FM-WTU-700



- Provides automatic chain stretch take-up
- Reduces noise caused from catenary tail
- Must be used with GP Drive End, sold separately
- Used on conveyors over 12 M long

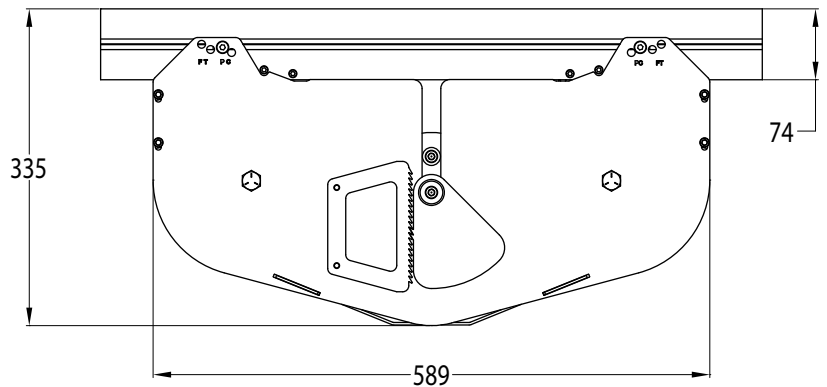
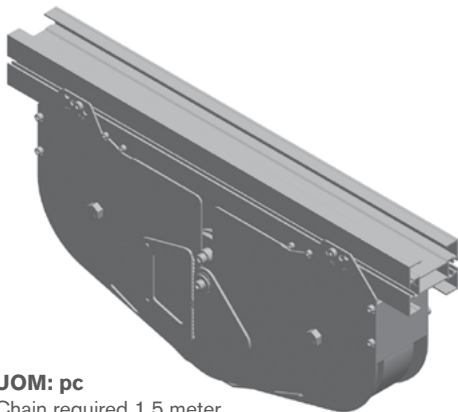
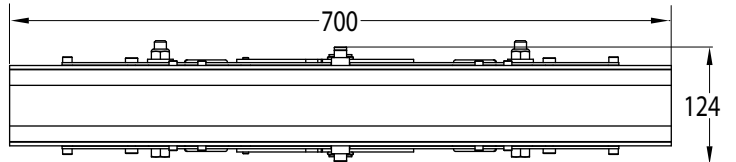

UOM: pc
Chain required 1.5 meter
Slide rail required 2.1 meter

FM Weighted Take-up Tail Module

FM-WTU-085

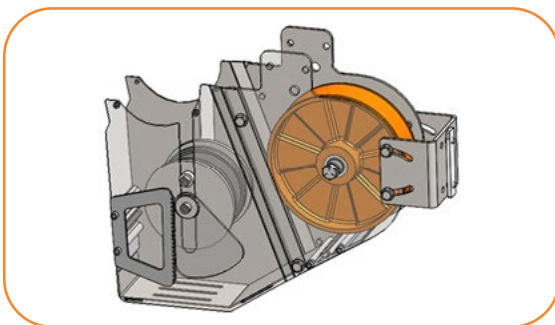

- Provides controlled chain take-up for improved conveyor performance
- Compact design fits in similar space as standard direct drive modules
- Smooths conveyor chain movement by helping to eliminate micro-surfing
- Suggested for conveyors over 12.2 M (40 ft) in length
- Capable of inclined and declined arrangement up to 30 degrees
- Improves operator safety by enclosing chain catenary
- Attaches to direct end drive tail
- Compatible with power transfer and driven bridge

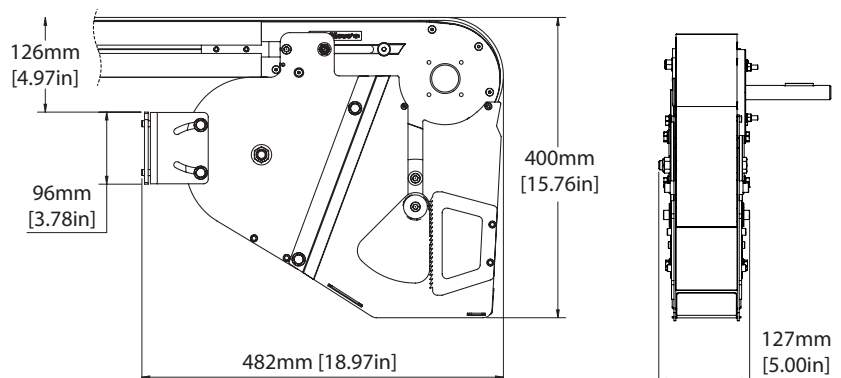
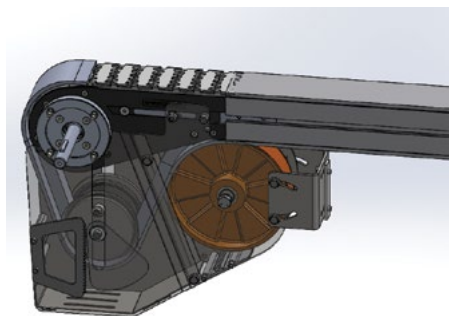
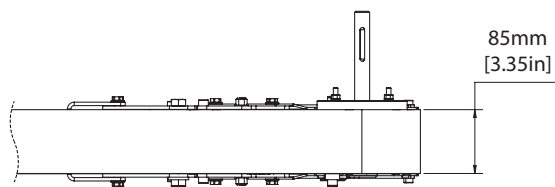

UOM: pc
Chain required 1.5 meter
Slide rail required 2.1 meter

FM Top Running Drive Module

FMTRD-203

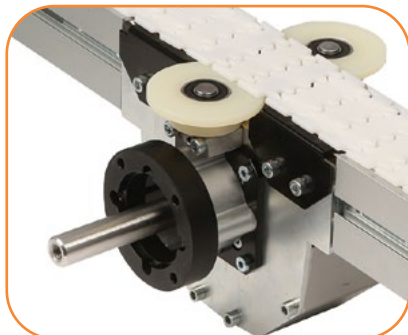

- For top running chain only
- 9M long conveyor length maximum
- 32 Kg load maximum
- Compatible with 3/4 inch shaft gearmotors only

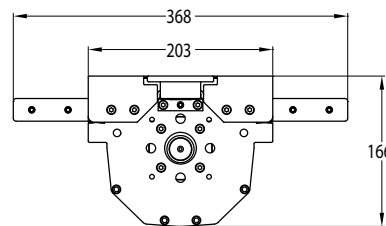
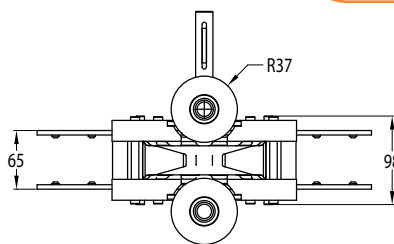
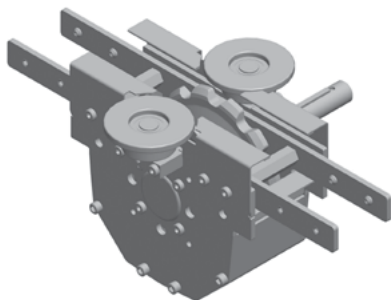

UOM: pc
Chain required 0.2 meter

FM Direct Wheel Drive without Motor

FMWD-DD-0M

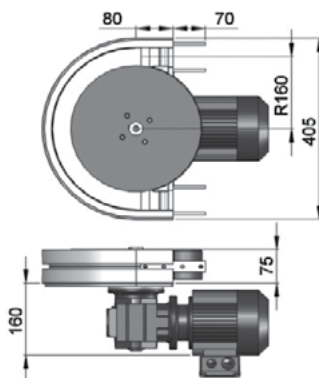
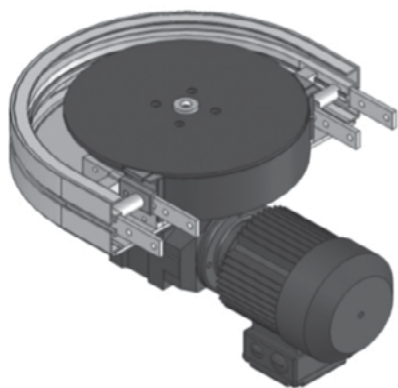

Max Traction Force: 200N

The Direct Wheel Drive Unit is without torque limiter. FMWD-DD-0M represents wheel drive without gear motor. Maximum traction force for FMWD-DD is lower than FMDD and FMDS.

UOM: pc
Chain required 1-way: 0.7 meter
Slide rail required 1-way: 0.7 meter

FM Suspended Wheel Drive without Motor

FMWD-SD-0M

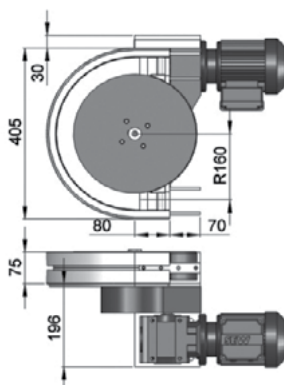
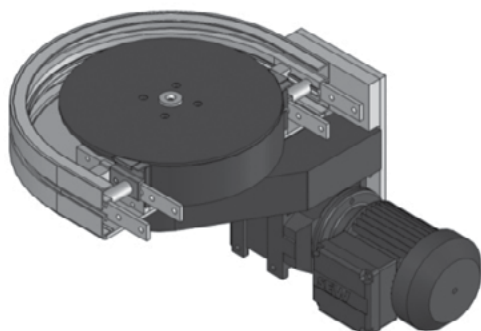

Max Traction Force: 200N

The Suspended Wheel Drive Unit is with torque limiter. FMWD-SD-0M represents wheel drive without gear motor. Maximum traction force for FMWD-SD is lower than FMDD and FMDS.

UOM: pc
Chain required 1-way: 0.7 meter
Slide rail required 1-way: 0.7 meter

SEW gearmotors are products of SEW Eurodrive

FM Idler End-65

FMIE-A85

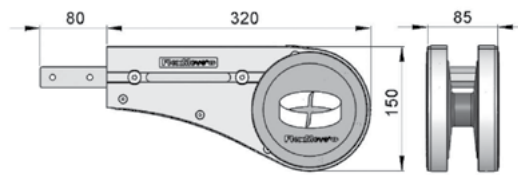
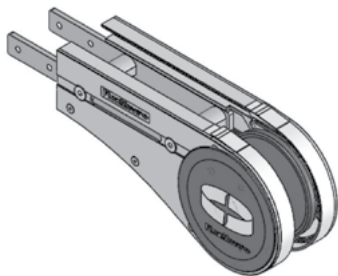

UOM: pc
Chain required 2-way: 0.8 meter
Slide rail required 2-way: 0.5 meter

FM Idler End with Power Transfer (LEFT)

FMIE-A85PT-L

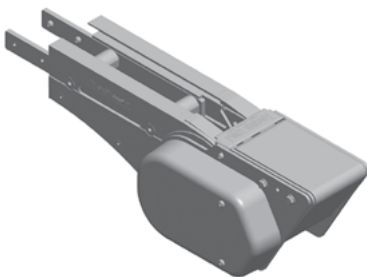

UOM: pc

Minimum product length for inline transfer = 100 mm
Provides extended transfer nose for interfacing with large rollers.

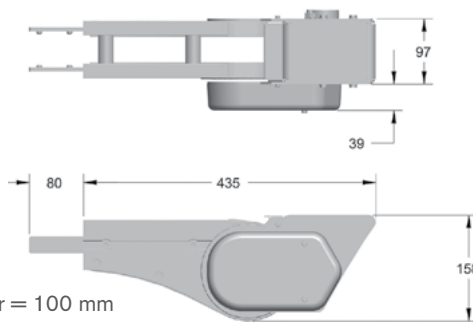

FM Idler End with Power Transfer (LEFT)

FMIE-A65PT-R

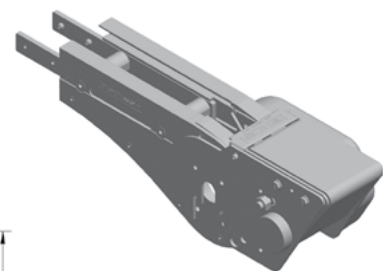

UOM: pc
Chain required 2-way: 0.8 meter
Slide rail required 2-way: 0.5 meter

FM Idler End Driven Transfer Bridge (LEFT)

FMIE-A85DB-A-L

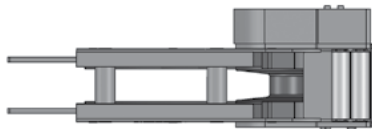

Minimum product length for inline transfer = 100 mm
Transfer extends past conveyor only 27 mm

UOM: pc
Chain required 2-way: 0.8 meter
Slide rail required 2-way: 0.5 meter

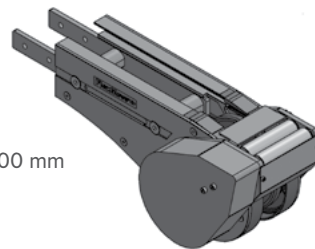

FM Direct Drive Driven Transfer Bridge (RIGHT)

FMIE-A85DB-A-R

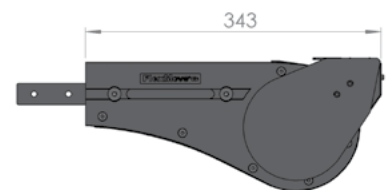
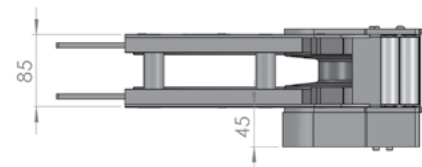

FM Idler Free Roller Transfer Bridge

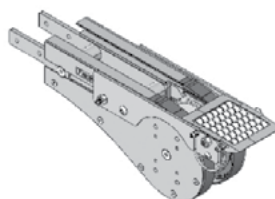
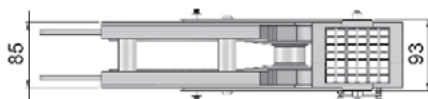

FMTB-A85

Transfer bridge c/w roller for FMIE-A85,
FMDD-A85-XDY and FMDD-A85GP-XDY

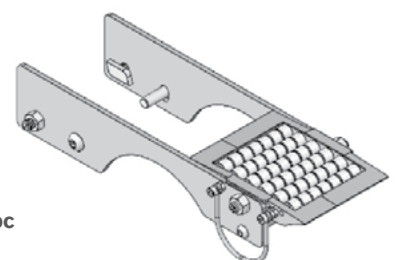

UOM: pc

FM Idler End Free Roller Bridge

FMEB-A85

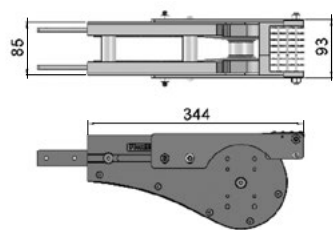

UOM: pc

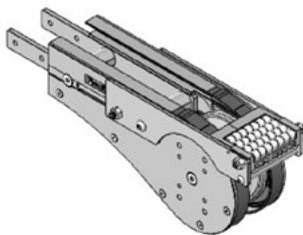

End transfer bridge c/w roller for FMIE-A85, FMDD-A85-XDY and FMDD-A85GP-XDY

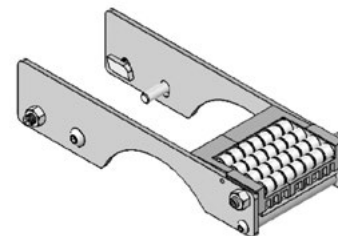

UOM: pc

FM Idler End-315

FMIE-315B

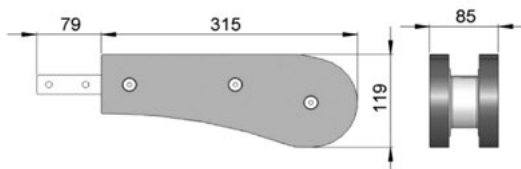
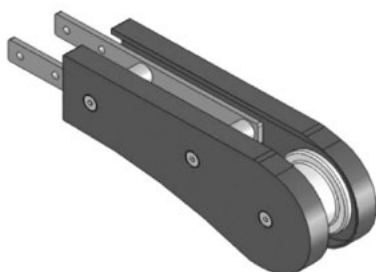

UOM: pc
Chain required 2-way: 0.8 meter
Slide rail required 2-way: 0

FM Idler Bend

FMIB-300

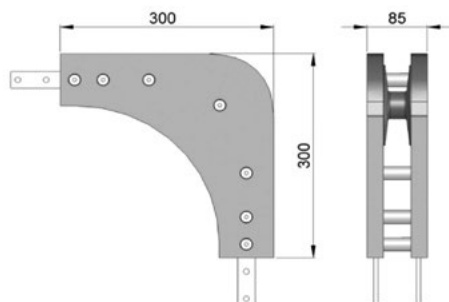

UOM: pc
Chain required 1-way: 0.6 meter
Slide rail: 0 meter
Note: Cannot be used with return chain

FM Wheel Bend 180°

FMWB-180R160A

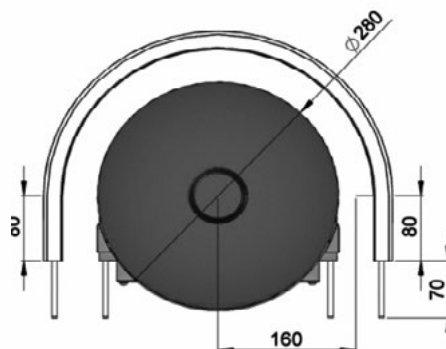
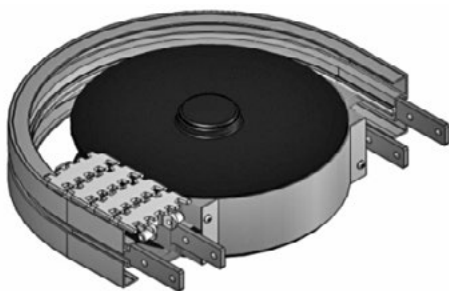

UOM: pc
Chain required 2-way: 1.3 meter
Slide rail required 2-way: 1.3 meter

FM Wheel Bend 90°

FMWB-90R160A

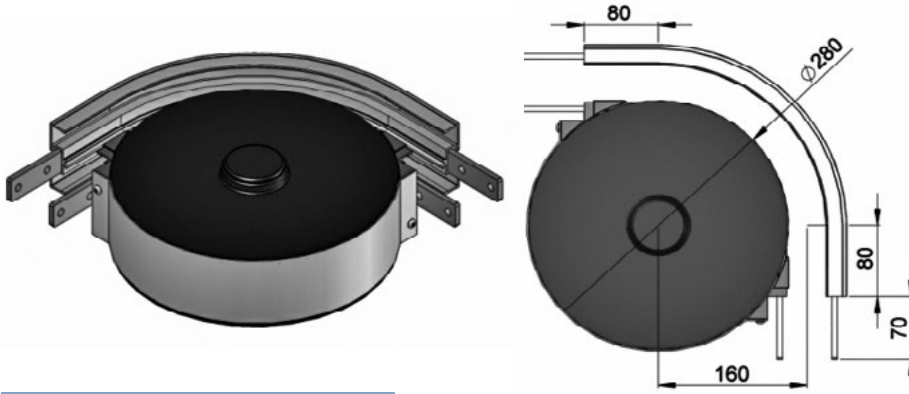

UOM: pc
 Chain required 2-way: 0.8 meter
 Slide rail required 2-way: 0.8 meter

FM Wheel Bend 60°

FMWB-60R160A

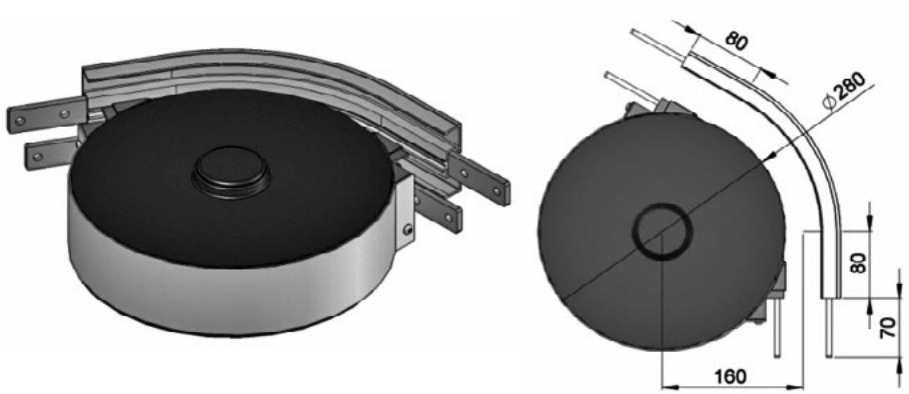

UOM: pc
 Chain required 2-way: 0.7 meter
 Slide rail required 2-way: 0.7 meter

FM Wheel Bend 45°

FMWB-45R160A

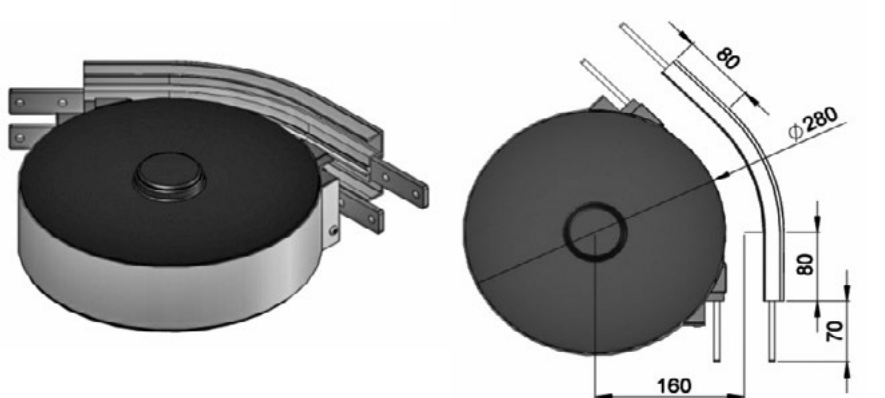

UOM: pc
 Chain required 2-way: 0.6 meter
 Slide rail required 2-way: 0.6 meter

FM Wheel Bend 30°

FMWB-30R160A

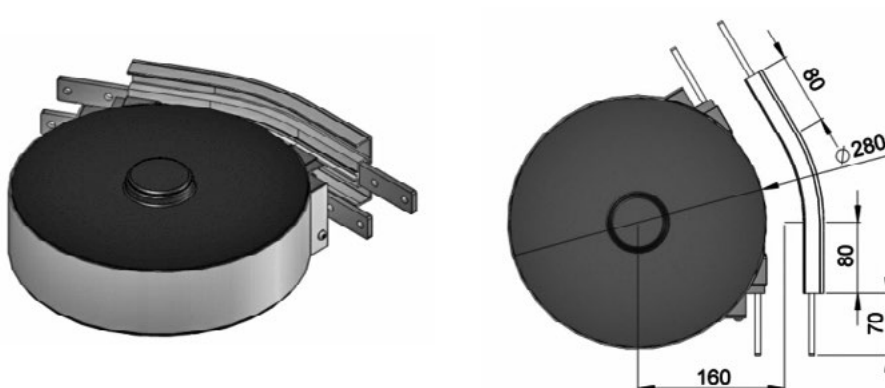

UOM: pc
 Chain required 2-way: 0.5 meter
 Slide rail required 2-way: 0.5 meter

FM Wheel Bend 5° - 180°

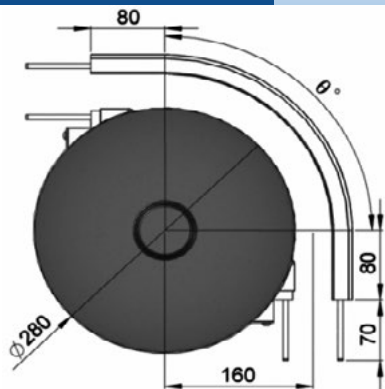

Example for FM Wheel Bend Ordering

- Wheel bend, $\varnothing \pm 1^\circ$
- FMWB- $\varnothing^\circ R160A$

If an angle of 65° is needed for wheel bend, the ordering part number is

FMWB-65R160A

The outer bend is assembled using connecting strip (FACS-25x140A). Angle of \varnothing° must be indicated when ordering.

FM Horizontal Plain Bend 15°

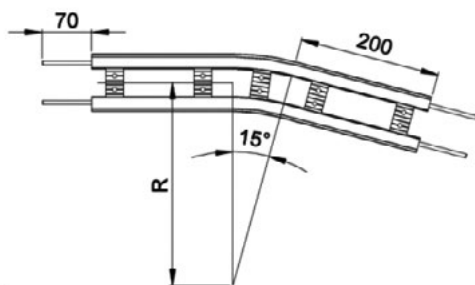
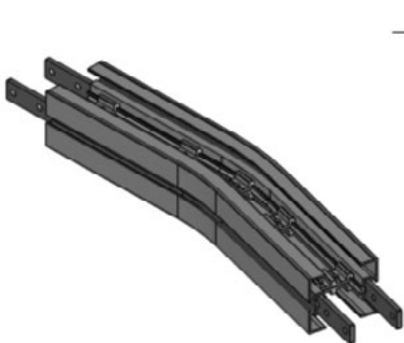

Horizontal plain bend, 15° ± 1°

R = 300 ± 10 mm	FMHB-15R300
R = 500 ± 10 mm	FMHB-15R500
R = 700 ± 10 mm	FMHB-15R700
R = 1000 ± 10 mm	FMHB-15R1000

UOM: pc

Chain required 2-way (300, 500, 700, 1000): 1, 1.1, 1.2, 1.4 meter
Slide rail required 2-way (300, 500, 700, 1000): 2, 2.2, 2.4, 2.8 meter

FM Horizontal Plain Bend 30°

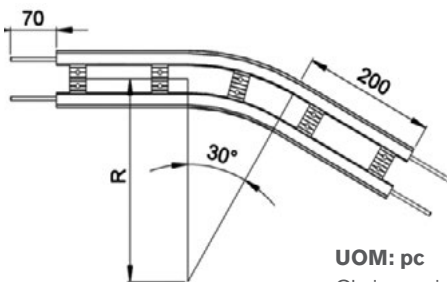

Horizontal plain bend, 30° ± 1°

R = 300 ± 10 mm	FMHB-30R300
R = 500 ± 10 mm	FMHB-30R500
R = 700 ± 10 mm	FMHB-30R700
R = 1000 ± 10 mm	FMHB-30R1000

UOM: pc

Chain required 2-way (300, 500, 700, 1000): 1.2, 1.4, 1.6, 1.9 meter
Slide rail required 2-way (300, 500, 700, 1000): 2.4, 2.8, 3.2, 3.8 meter

FM Horizontal Plain Bend 45°

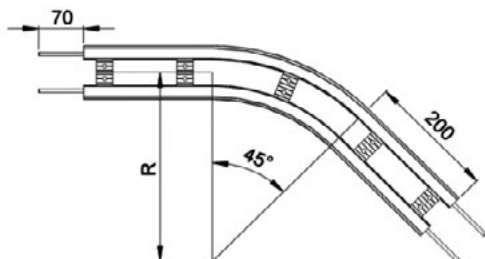
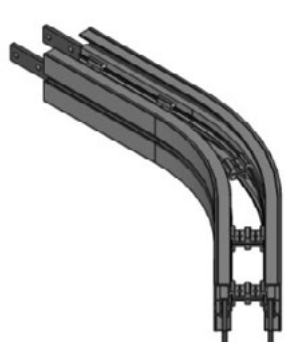

Horizontal plain bend, 45° ± 1°

R = 300 ± 10 mm	FMHB-45R300
R = 500 ± 10 mm	FMHB-45R500
R = 700 ± 10 mm	FMHB-45R700
R = 1000 ± 10 mm	FMHB-45R1000

UOM: pc

Chain required 2-way (300, 500, 700, 1000): 1.3, 1.6, 1.9, 2.4 meter
Slide rail required 2-way (300, 500, 700, 1000): 2.5, 2.9, 3.3, 3.9 meter

FM Horizontal Plain Bend 60°

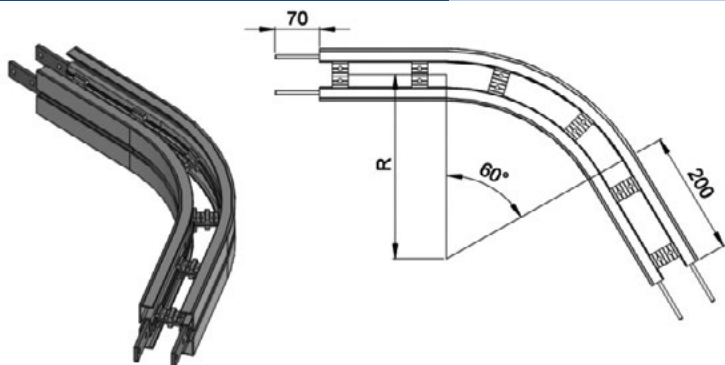

Horizontal plain bend, 60° ± 1°

R = 300 ± 10 mm	FMHB-60R300
R = 500 ± 10 mm	FMHB-60R500
R = 700 ± 10 mm	FMHB-60R700
R = 1000 ± 10 mm	FMHB-60R1000

UOM: pc

Chain required 2-way (300, 500, 700, 1000): 1.5, 1.9, 2.3, 2.9 meter
 Slide rail required 2-way (300, 500, 700, 1000): 2.9, 3.7, 4.6, 5.8 meter

FM Horizontal Plain Bend 90°

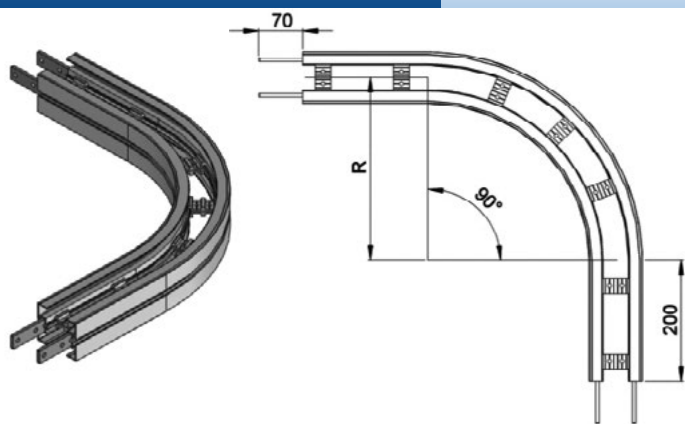

Horizontal plain bend, 90° ± 1°

R = 300 ± 10 mm	FMHB-90R300
R = 500 ± 10 mm	FMHB-90R500
R = 700 ± 10 mm	FMHB-90R700
R = 1000 ± 10 mm	FMHB-90R1000

UOM: pc

Chain required 2-way (300, 500, 700, 1000): 1.8, 2.4, 3.0, 4.0 meter
 Slide rail required 2-way (300, 500, 700, 1000): 3.5, 4.8, 6.0, 8.0 meter

FM Horizontal Plain Bend 180°

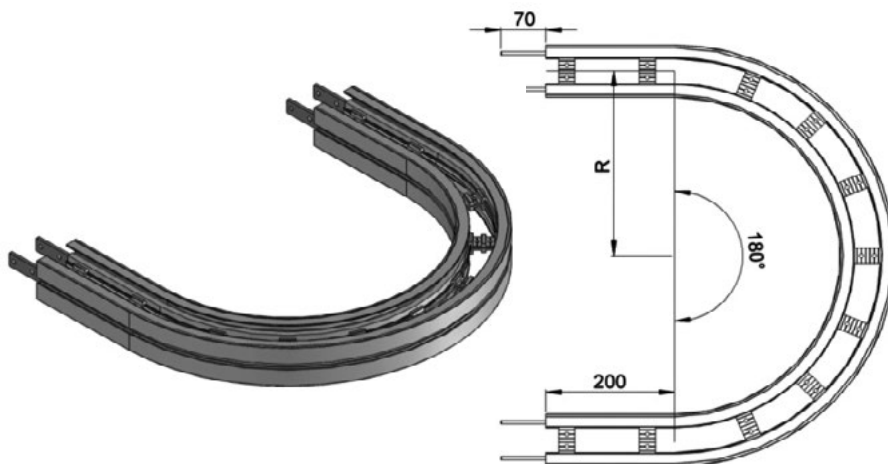

Horizontal plain bend, 180° ± 1°

R = 300 ± 10 mm	FMHB-180R300
R = 500 ± 10 mm	FMHB-180R500
R = 700 ± 10 mm	FMHB-180R700
R = 1000 ± 10 mm	FMHB-180R1000

UOM: pc

Chain required 2-way (300, 500, 700, 1000): 2.7, 4.0, 5.2, 7.1 meter
 Slide rail required 2-way (300, 500, 700, 1000): 5.4, 7.9, 1.1, 14.2 meter

FM Horizontal Plain Bend 5° - 180°

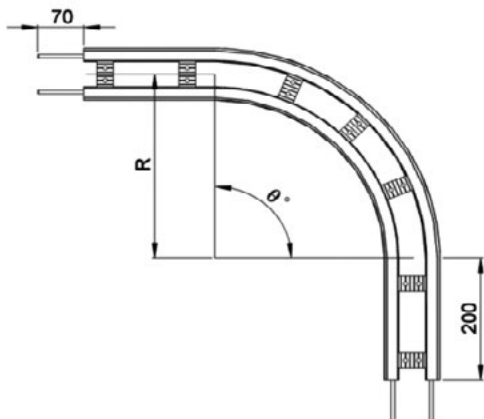

Example for FM Horizontal Plain Bend Ordering

Horizontal plain bend, $\theta^\circ \pm 1^\circ$

- R = 300 ± 10 mm **FMHB- θ° R300**
- R = 500 ± 10 mm **FMHB- θ° R500**
- R = 700 ± 10 mm **FMHB- θ° R700**
- R = 1000 ± 10 mm **FMHB- θ° R1000**

If an angle of 120° is needed for radius R500 horizontal plain bend, the ordering part number is

FMHB-120R500

UOM: pc

Chain required 2-way (300, 500, 700, 1000): meter (Variable to angle)
 Slide rail required 2-way (300, 500, 700, 1000): meter (Variable to angle)

FM Vertical Bend 5°

FMVB-5R400

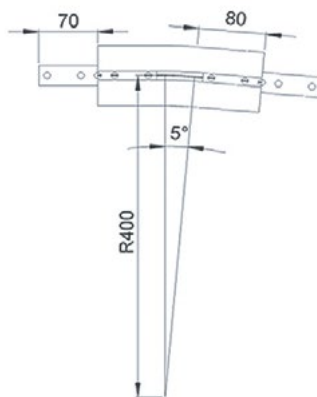
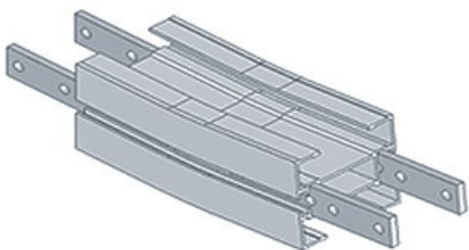

UOM: pc

Chain required 2-way: 0.4 meter
 Slide rail required 2-way: 0.8 meter

FM Vertical Bend 10°

FMVB-10R400

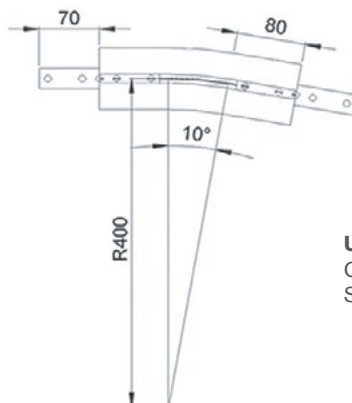
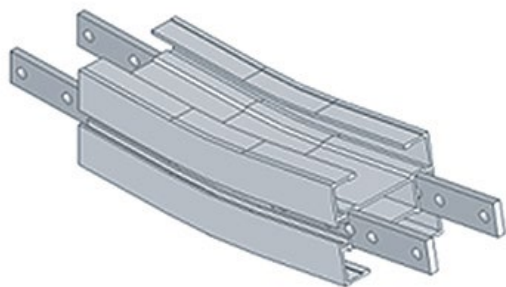

UOM: pc

Chain required 2-way: 0.5 meter
 Slide rail required 2-way: 1.1 meter

FM Vertical Bend 15°

FMVB-15R400

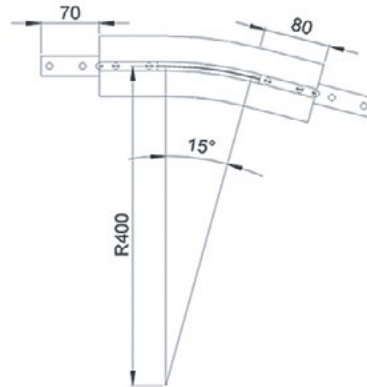
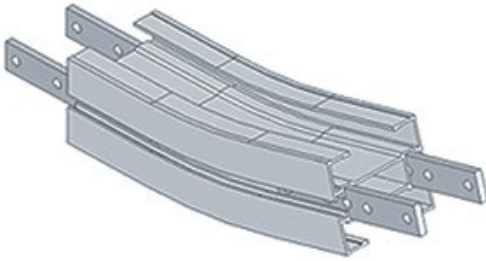

UOM: pc

Chain required 2-way: 0.5 meter
Slide rail required 2-way: 1.1 meter

FM Vertical Bend 20°

FMVB-20R400

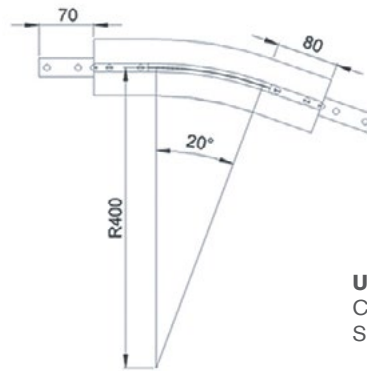
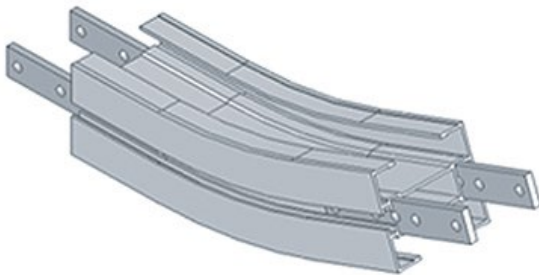

UOM: pc

Chain required 2-way: 0.6 meter
Slide rail required 2-way: 1.2 meter

FM Vertical Bend 30°

FMVB-30R400

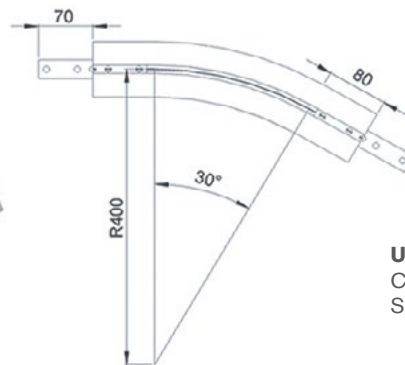
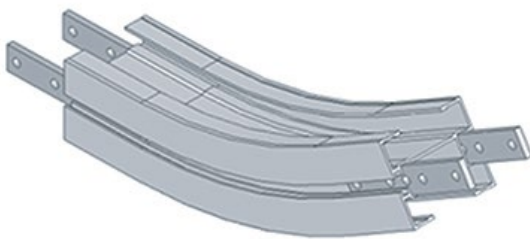

UOM: pc

Chain required 2-way: 0.7 meter
Slide rail required 2-way: 1.5 meter

FM Vertical Bend 45°

FMVB-45R400

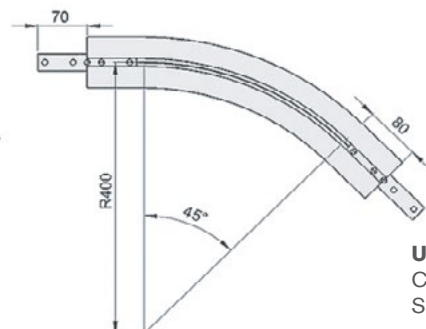
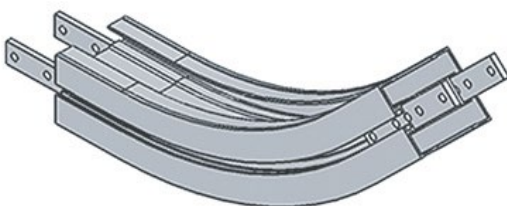

UOM: pc

Chain required 2-way: 0.9 meter
Slide rail required 2-way: 1.9 meter

FM Vertical Bend 60°

FMVB-60R400

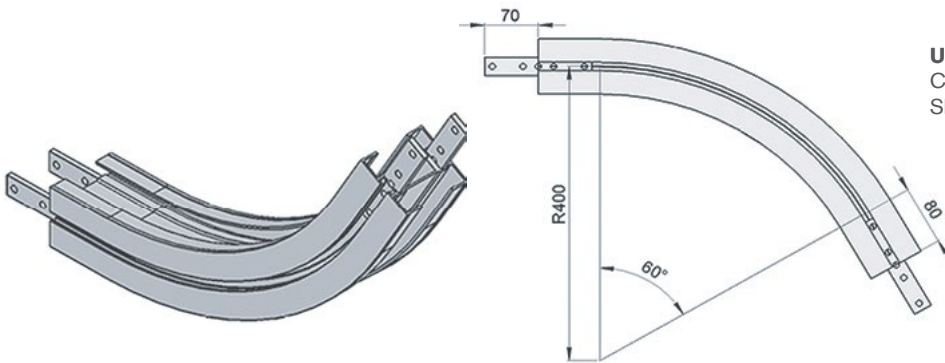

UOM: pc

Chain required 2-way: 1.2 meter
Slide rail required 2-way: 2.3 meter

FM Vertical Bend 90°

FMVB-90R400

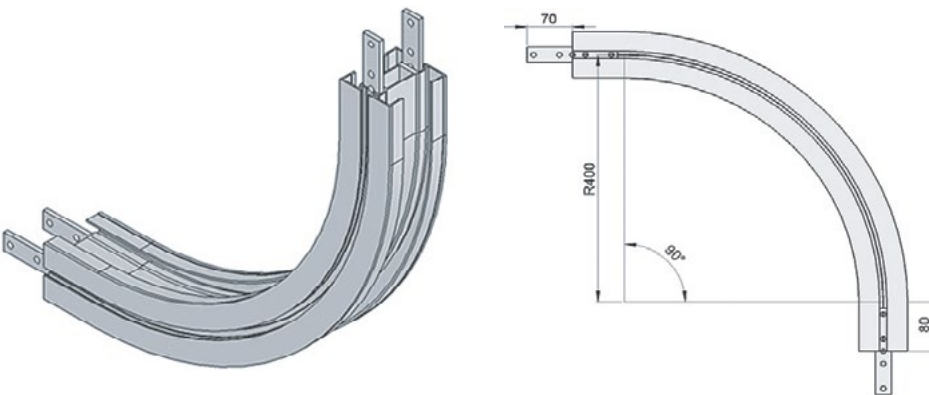

UOM: pc

Chain required 2-way: 1.6 meter
Slide rail required 2-way: 3.2 meter

FM Vertical Bend 5° - 90°

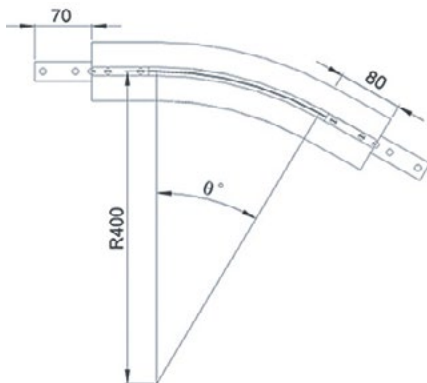

Example for FM Vertical Bend Ordering

- Vertical bend, $\varnothing \pm 1^\circ$
- FMVB- \varnothing° R400

If an angle of 65° is needed for vertical bend, the ordering part number is

FMVB-65R400

The outer bend is assembled using connecting strip (FACS-25x140A). Angle of "θ" must be indicated when ordering.

FM 45 Degree Twist Conveyor Beam (Clockwise)

FMTB-CW45x3000

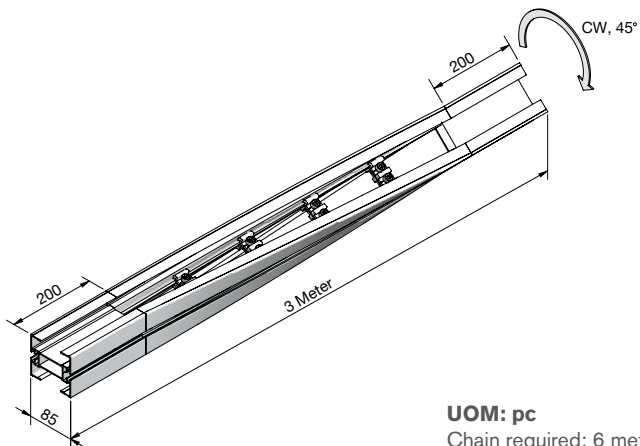

UOM: pc
Chain required: 6 meter
Slide rail required: 12 meter

FM 45 Degree Twist Conveyor Beam (Counter-Clockwise)

FMTB-CCW45x3000

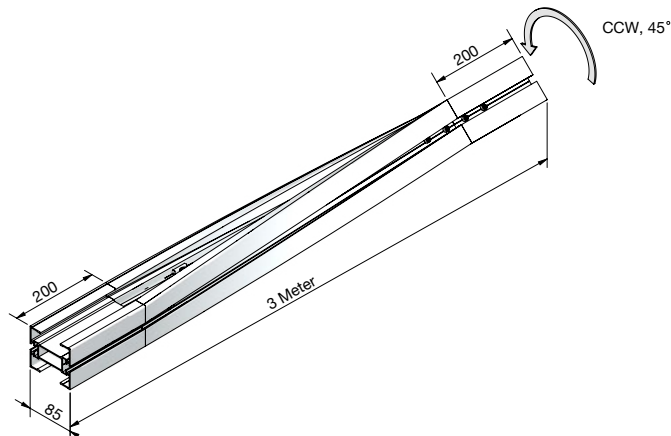

FM 90 Degree Twist Conveyor Beam (Clockwise)

FMTB-CW90x3000

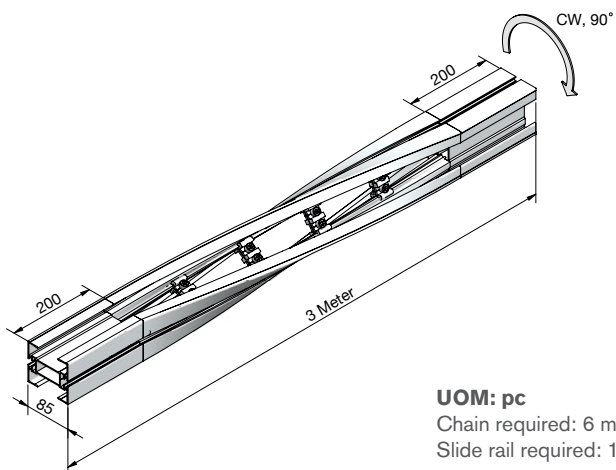

UOM: pc
Chain required: 6 meter
Slide rail required: 12 meter

FM 90 Degree Twist Conveyor Beam (Counter-Clockwise)

FMTB-CCW90x3000

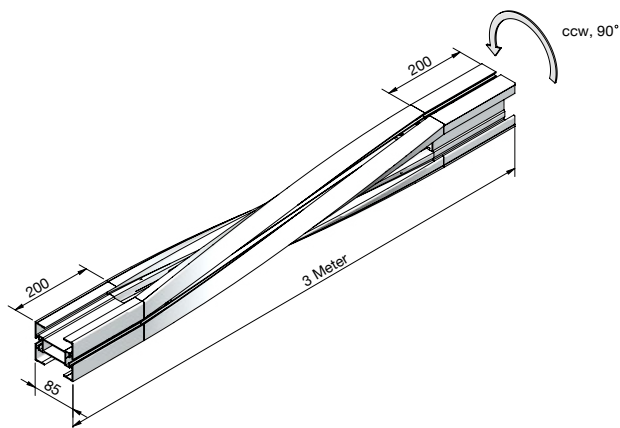

FM Twist Conveyor Beam 15° - 90°

FMTB-AAABBx3000

Where AAA = CW or CCW, BB = Angle

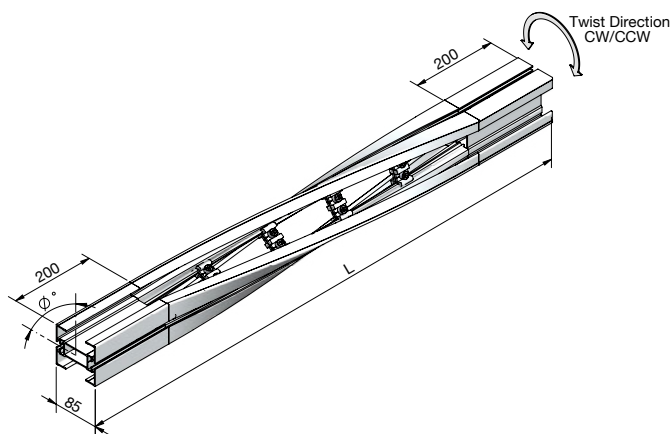

Example for FM Twist Conveyor Beam Ordering

- Twist Conveyor Beam, $\text{Ø}^\circ \pm 5^\circ$

If an angle of 30° is needed for twist beam, in clockwise direction and length 3.0 m, the ordering part number is

FMTB-CW30x3000

Angle of Ø° , twist direction, and length L , must be indicated when ordering.

UOM: pc
Chain required: 6 meter
Slide rail required: 12 meter

FM S In-Line Transfer Module

FMST-085

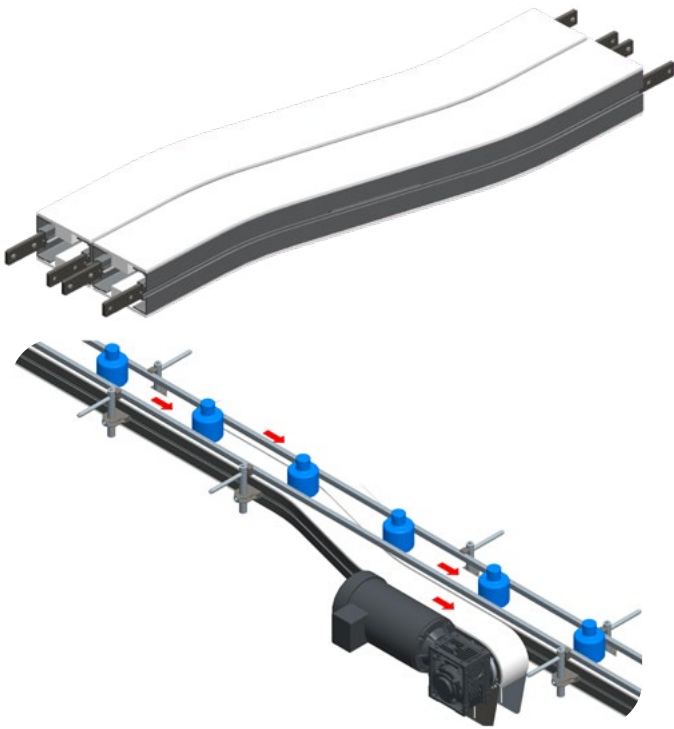

- S In-Line Modules provide a standard, compact way to side transfer product from conveyor to conveyor.
- Straight guiding is placed across the transfer module for smooth In-Line product flow
- Conveyors are mounted together to provide a smooth transfer even for small products
- S In-Line transfers are compact in the width dimension

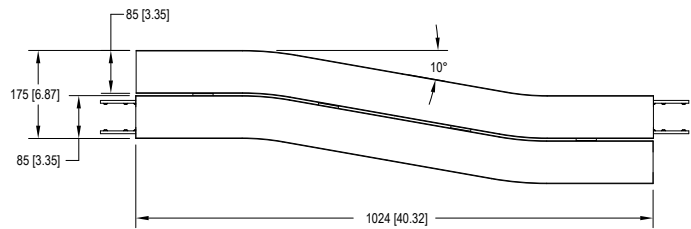

FM X In-Line Transfer Module

FMXT-085



- X In-Line Modules provide a standard, compact way to side transfer product from conveyor to conveyor.
- Straight guiding is placed across the transfer module for smooth In-Line product flow
- Conveyors are mounted together to provide a smooth transfer even for small products
- X In-Line transfers are compact in the length direction

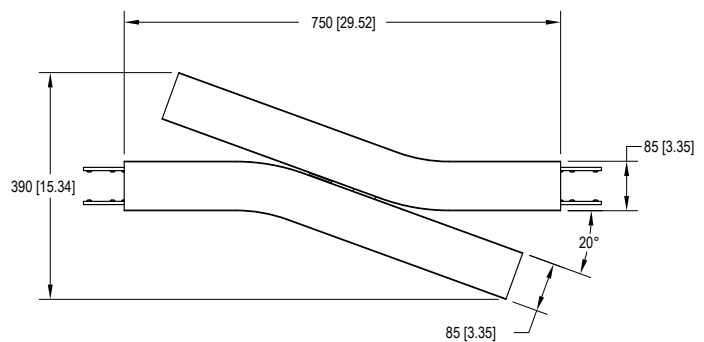

Variety of chain type suitable for wide range of applications either horizontal or vertical product transportation. Capacity higher than FK, FS, FM. The maximum product width to be conveyed can be referred to guide rail assembly pages.

FC Series Characteristic

Beam Width: 105 mm

Product Width: Refer to Guide Rail Assembly

Accessories Needed

Slide Rail Required: FASR-25 OR FASR-25U

Slide Rail Color: White or Natural Color

Slide Rail Material: HDPE OR UHMW-PE

Slide Rail Rivet & Screw: FASLR-4X6 or FASLS-M5

Connecting strip is used to connect two beams.

Connecting Strip: FACS-25x140A

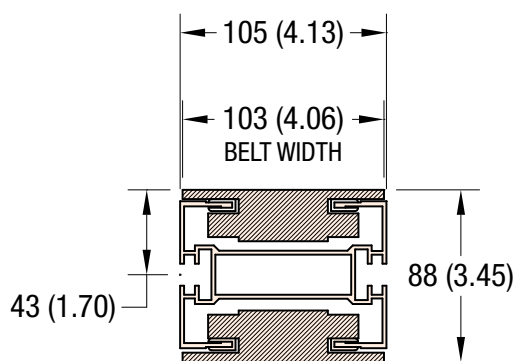

105 MM WIDTH

Conveyor Beam FCCB-3

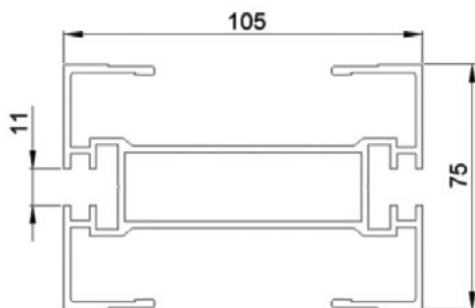

UOM: 3 Meter / Length

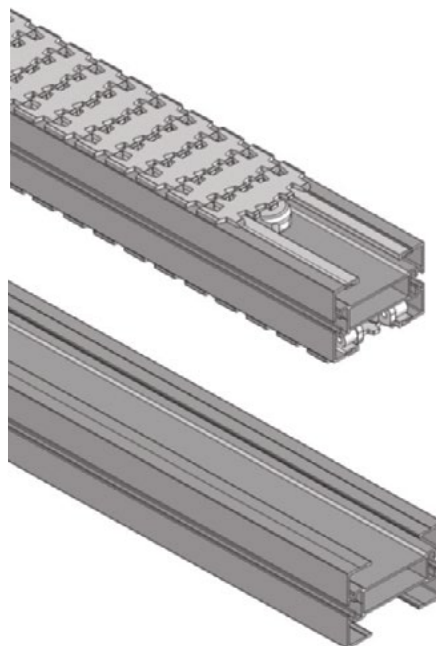

Chain Connecting Module FCCC-160

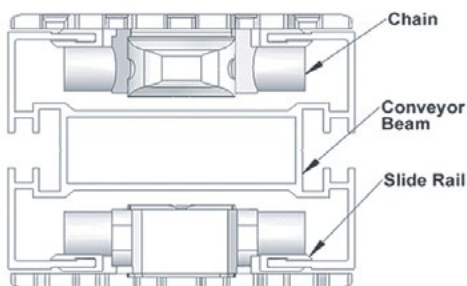

UOM: pc

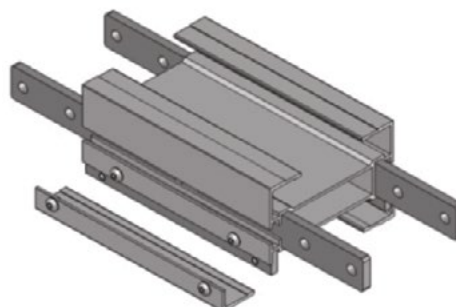

Chain Common Data

Packaging: 5 m per box

Pitch: 35.5 mm

Width: 103 mm

Tensile Strength at 20°C: 6000N

Color: White & Black (Conductive)

Material:

Chain: White Acetal / POM

Pivot: Polyamide

Pivot Pin: Stainless Steel

Insert (Wedge & Friction): TPE Grey

Example for FCCT-5A17-L#

= 1 cleated top chain with alternate of # link of plain chain

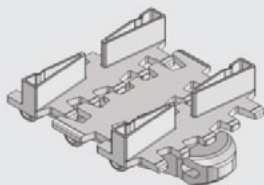

The above chain is FCCT-5A17-L1, 1 link cleated top chain with alternate of 1 link of plain chain.

Note: # = 1, 2, 3, 4, 5.....20

Standard Plain Chain FCPC-5

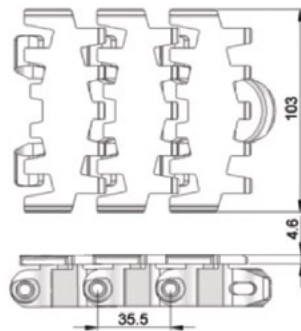
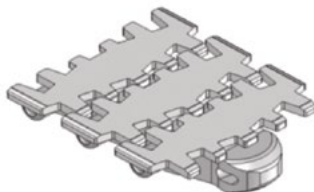

UOM: 5 Meter / box

Application: Suitable for horizontal and slope < 5° transport of products with accumulation.

Conductive Chain FCPC-5CD

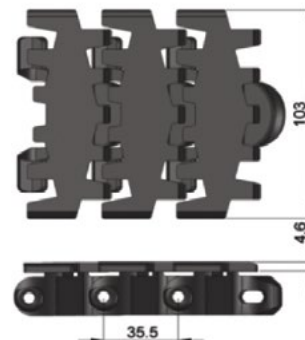
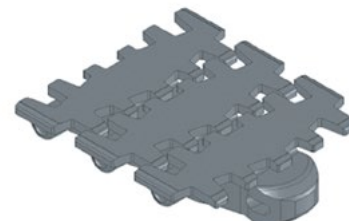

UOM: 5 Meter / box

Application: Suitable for transport of static sensitive product.

Cleat Top Chain FCCT-5A17-L#

= 1, 2, 3, 4, 5.....20

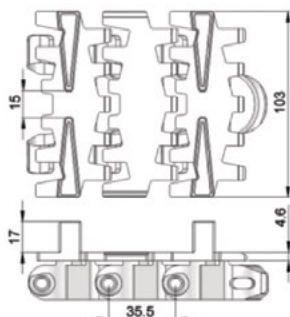
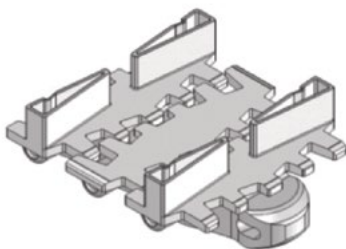

UOM: 5 Meter / box

Application: Suitable for vertical transport of product with no accumulation.

Cleat Top Chain FCCT-5A30-L#

= 1, 2, 3, 4, 5.....20

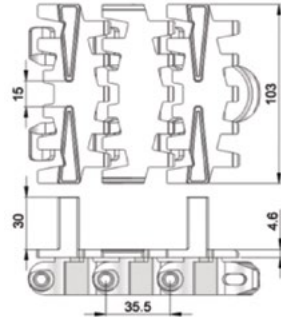
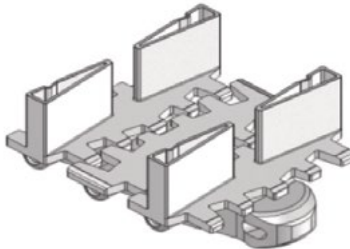

UOM: 5 Meter / box

Application: Suitable for vertical transport of product with no accumulation.

Roller Top Chain FCRT-5

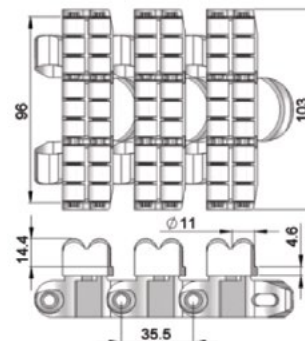
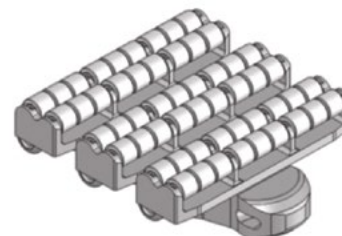

UOM: 5 Meter / box

Application: Suitable for accumulation of product with low friction and pressure.

Roller Cleat Chain FCRC-5A-L#

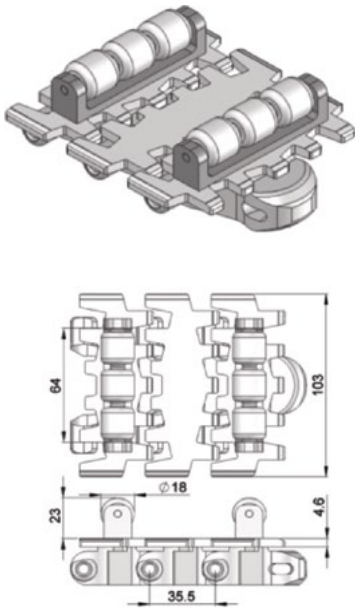

UOM: 5 Meter / box

Application: Suitable for vertical transportation of product in slope with no accumulation.

Roller Cleat Chain FCRC-5B-L#

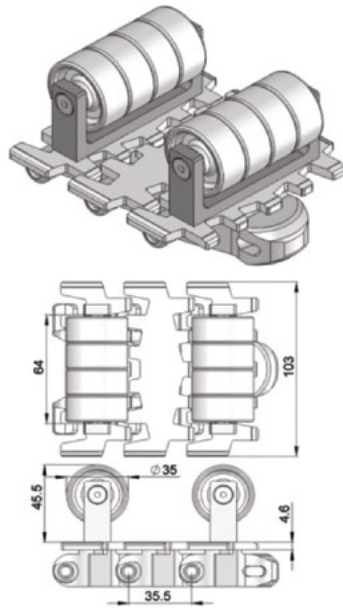

UOM: 5 Meter / box

Application: Suitable for vertical transportation of product in slope with no accumulation.

Friction Top Chain FCFT-5

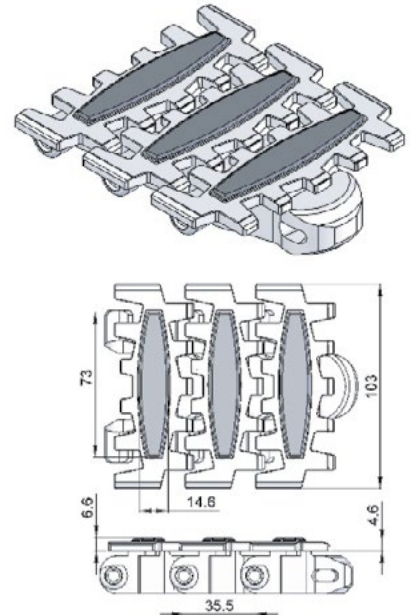

UOM: 5 Meter / box

Application: Suitable for transport product in slope $> 5^\circ$ but $\leq 30^\circ$ without accumulation.

Friction Top Chain FCFT-5A

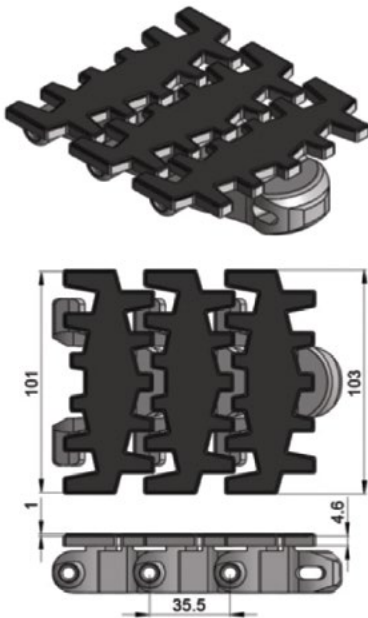

UOM: 5 Meter / box

Application: Suitable for transport product in of slope $> 5^\circ$ but $\leq 30^\circ$ without accumulation.

Friction Top Chain FCFT-5B

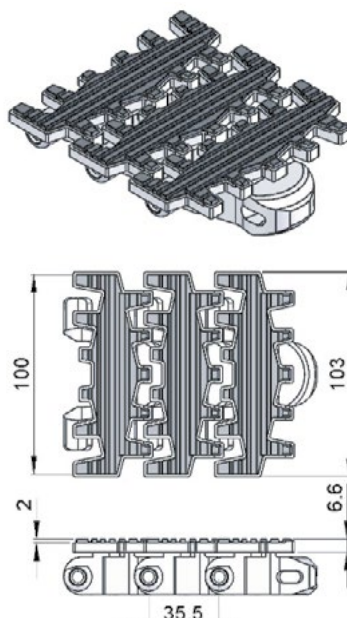

UOM: 5 Meter / box

Application: Suitable for transport product in slope $> 5^\circ$ but $\leq 40^\circ$ without accumulation.

Friction Top Chain FCFT-5C

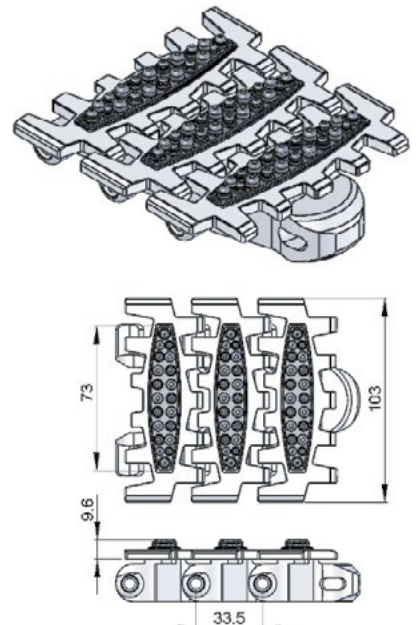

UOM: 5 Meter / box

Application: Suitable for transport product in of slope $> 5^\circ$ but $\leq 35^\circ$ without accumulation.

S/steel Top Chain **FCST-5S**

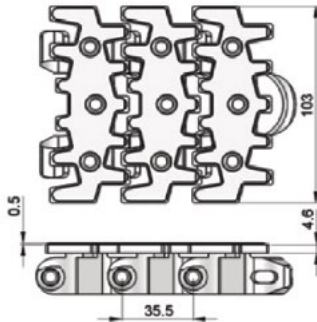
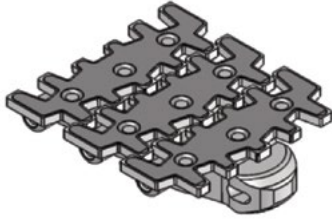

UOM: 5 Meter / box

Application: Suitable to transport metal products in accumulation.

Flocked Chain **FCFK-5**

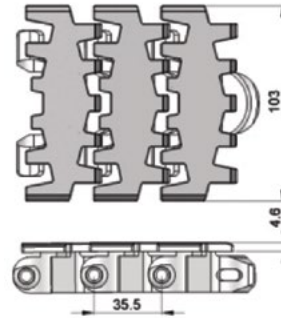
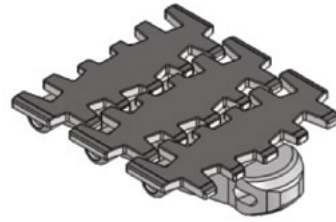

UOM: 5 Meter / box

Application: Suitable to transport lightweight, fragile and scratch sensitive product.

Safety Chain **FCPC-5V**

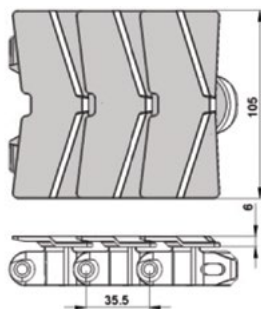
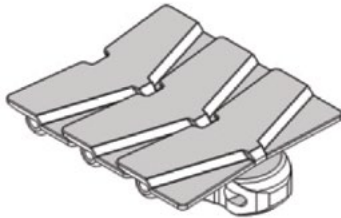

UOM: 5 Meter / box

Application: (Safety Chain) Suitable for horizontal and slope <math>< 5^\circ</math> transport of products with accumulation.

Twist Chain **FCPC-5M**

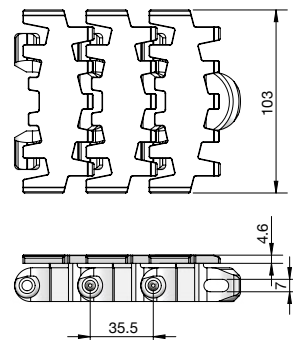
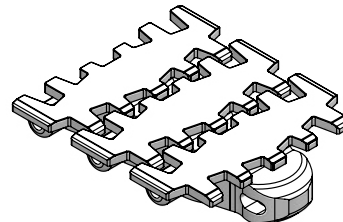

UOM: 5 Meter / box

Application: Suitable twist conveyor beam; horizontal and slope <math>< 5^\circ</math> transport of products with accumulation

FC Direct End Drive without Motor (LEFT)

FCDD-A105-XDY (See Chart)

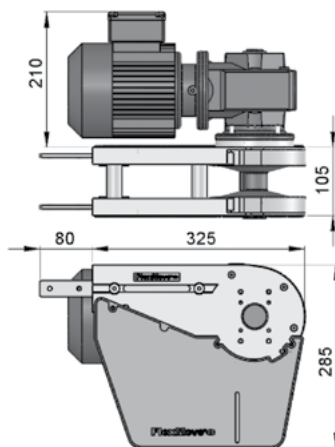
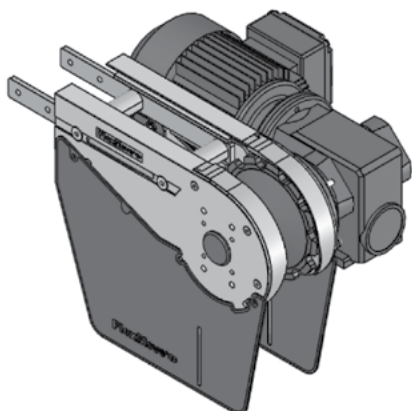

FC Direct End Drive without Motor (RIGHT)

FCDD-A105-XDY (See Chart)

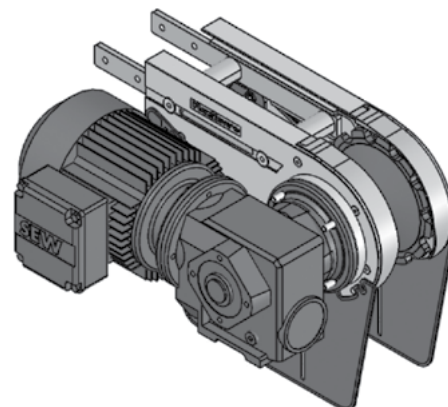

Part Number		Shaft Selection	Direction	Aux Shaft Selection
FCDD-A105	-	X	D	Y
		0 = 20 mm	L = Left	Blank = No Aux Shaft
		E = 3/4 in*	R = Right	A = 20 mm Aux Shaft
		A = 20 mm Aux Only		

*3/4 inch shaft option available in North America only.

Max Traction Force: 1250N

The Direct End Drive Unit is without torque limiter.

UOM: pc

Chain required 2-way: 0.8 meter
Slide rail required 2-way: 0.5 meter

FC Direct End Drive unit without Motor GP (LEFT)

FCDD-A105GP-XDY (See Chart)

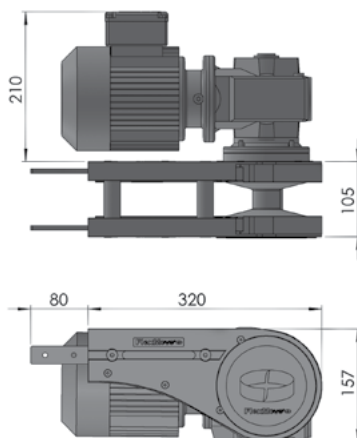
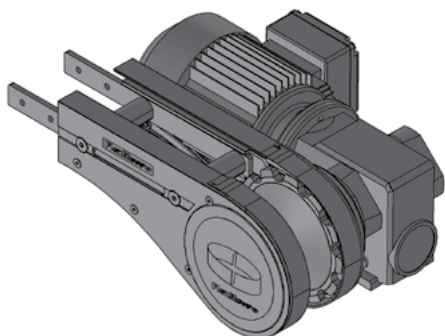

FC Direct End Drive unit without Motor GP (RIGHT)

FCDD-A105GP-XDY (See Chart)

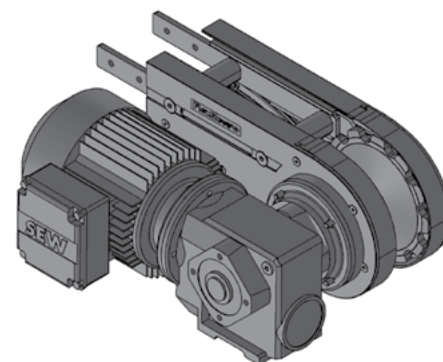

Requires the use of connecting or weighted take-up module for chain maintenance.

Part Number		Shaft Selection	Direction	Aux Shaft Selection
FCDD-A105GP	-	X	D	Y
		0 = 20 mm	L = Left	Blank = No Aux Shaft
		E = 3/4 in*	R = Right	A = 20 mm Aux Shaft
		A = 20 mm Aux Only		

*3/4 inch shaft option available in North America only.

Max Traction Force: 1250N

The Direct End Drive Unit GP is without torque limiter.

UOM: pc

Chain required 2-way: 0.8 meter
Slide rail required 2-way: 0.5 meter

SEW gearmotors are products of SEW Eurodrive

FC Direct with Power Transfer Motor (LEFT)

FCDD-A105PT-XD (See Chart)

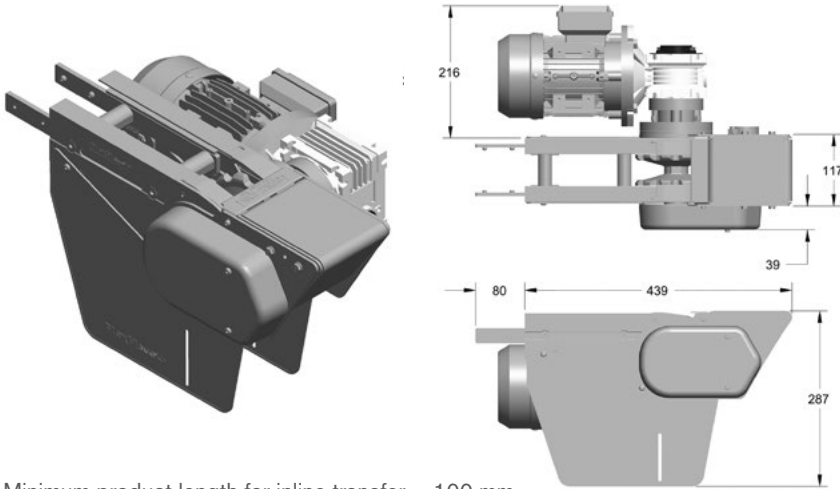

FC Direct with Power Transfer Motor (RIGHT)

FCDD-A105PT-XD (See Chart)

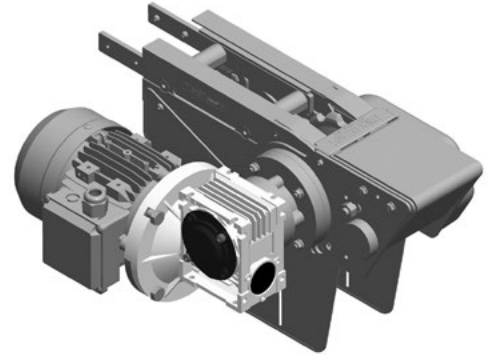

Minimum product length for inline transfer = 100 mm
 Maximum speed is 30 m/min (100 ft/min)
 Only one power transfer needed on either infeed or discharge trail required for end to end transfer. Provides extended transfer nose for interfacing with large rollers.

Part Number		Shaft Selection	Direction
FCDD-A105PT	-	X	D
		0 = 20 mm	L = Left
		E = 3/4 in*	R = Right

*3/4 inch shaft option available in North America only.

Max Traction Force: 1250N

The Direct End Drive Unit is without torque limiter.

UOM: pc

Chain required 2-way: 0.8 meter
 Slide rail required 2-way: 0.5 meter

FC GP Direct with Power Transfer Motor (LEFT)

FCDD-A105GPPT-XD (See Chart)

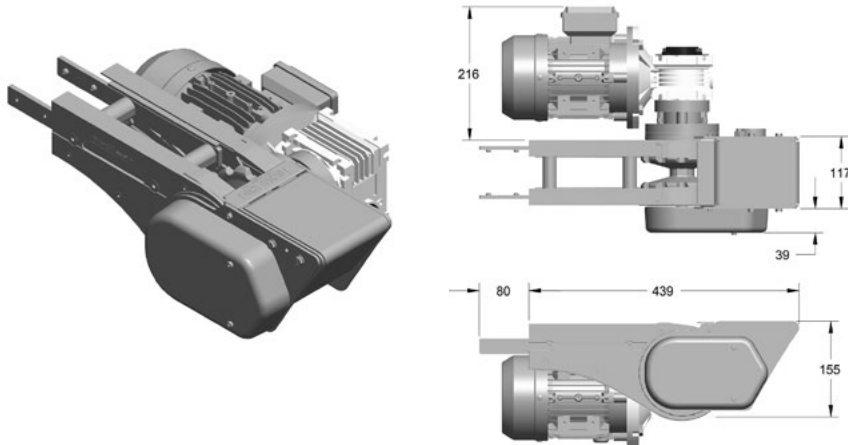

FC GP Direct with Power Transfer Motor (RIGHT)

FCDD-A105GPPT-XD (See Chart)

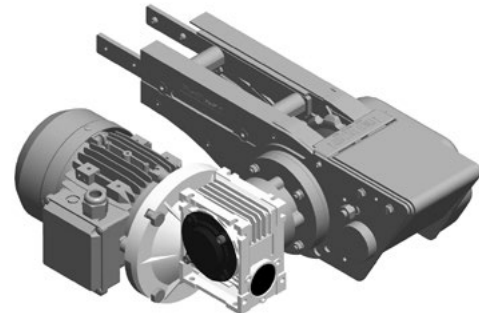

Minimum product length for inline transfer = 100 mm
 Maximum speed is 30 m/min (100 ft/min)
 Only one power transfer needed on either infeed or discharge trail required for end to end transfer. Provides extended transfer nose for interfacing with large rollers. Requires the use of connecting or weighted take-up module for chain maintenance.

Part Number		Shaft Selection	Direction
FCDD-A105GPPT	-	X	D
		0 = 20 mm	L = Left
		E = 3/4 in*	R = Right

*3/4 inch shaft option available in North America only.

Max Traction Force: 1250N

The Direct End Drive Unit GP is without torque limiter.

UOM: pc

Chain required 2-way: 0.8 meter
 Slide rail required 2-way: 0.5 meter

SEW gearmotors are products of SEW Eurodrive

FC Direct Drive Driven Transfer Bridge (LEFT)

FCDD-A105DB-A-0L

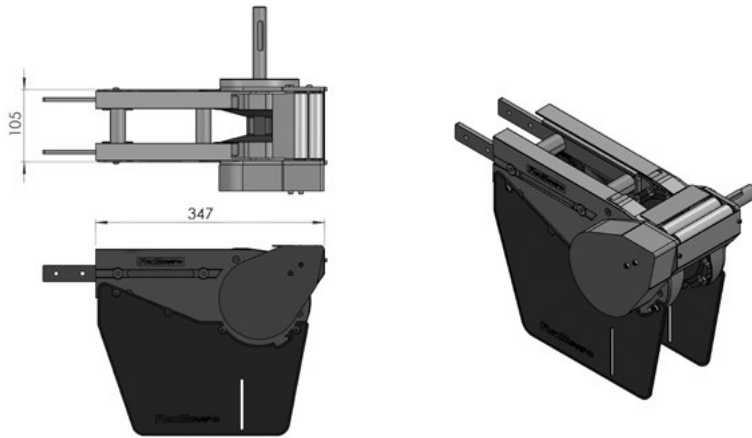

FC Direct Drive Driven Transfer Bridge (RIGHT)

FCDD-A105DB-A-0R

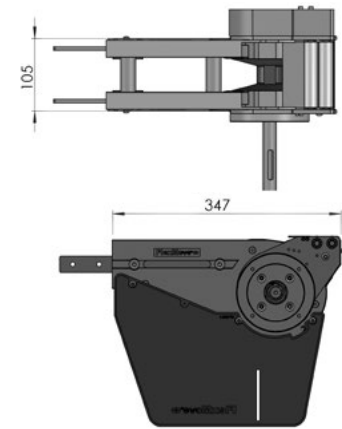

Max Traction Force: 1250N

The Direct End Drive Unit is without torque limiter.

UOM: pc

Chain required 2-way: 0.8 meter

Slide rail required 2-way: 0.5 meter

FC Direct Drive Free Roller Transfer Bridge (LEFT/RIGHT)

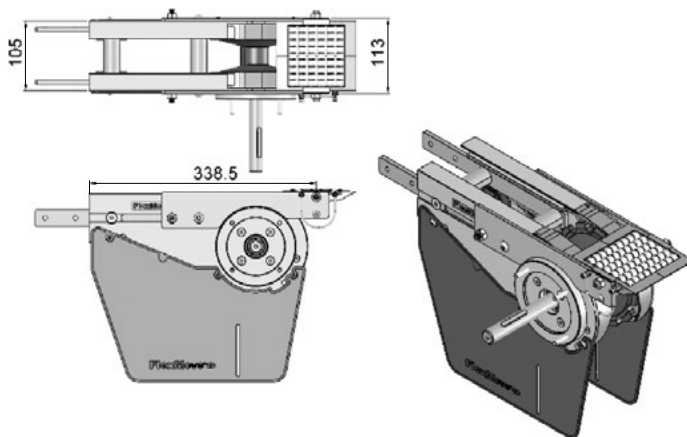

FCTB-A105

Transfer bridge c/w roller for FCIE-A105, FCDD-A105-XDY and FCDD-A105GP-XDY

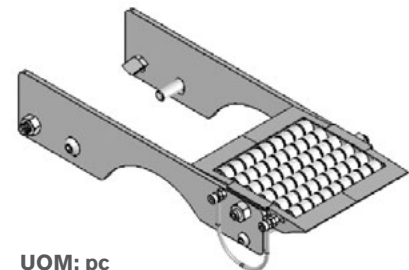

UOM: pc

FC Direct Drive End Free Roller Bridge (LEFT/RIGHT)

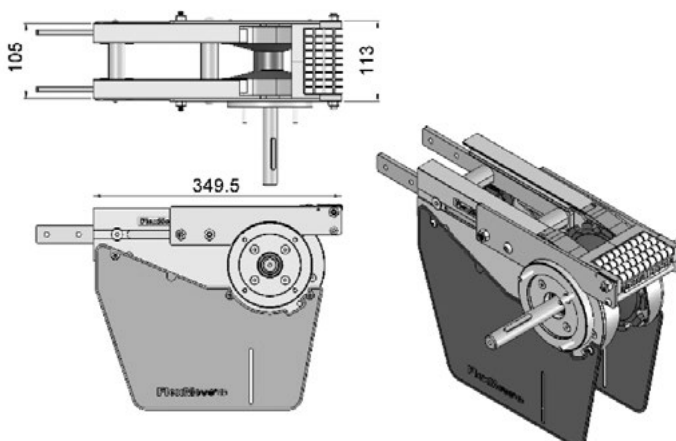

FCEB-A105

End transfer bridge c/w roller for FCIE-A105, FCDD-A105-XDY and FCDD-A105GP-XDY

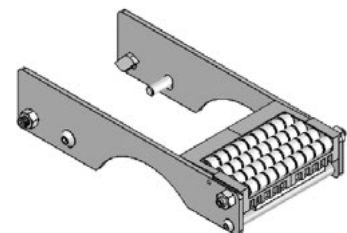

UOM: pc

SEW gearmotors are products of SEW Eurodrive

FC Suspended End Drive without Motor (LEFT)

FCSD-A105-0L (with Torque Limiter)
FCSD-A105SPT-0L (without Torque Limiter)

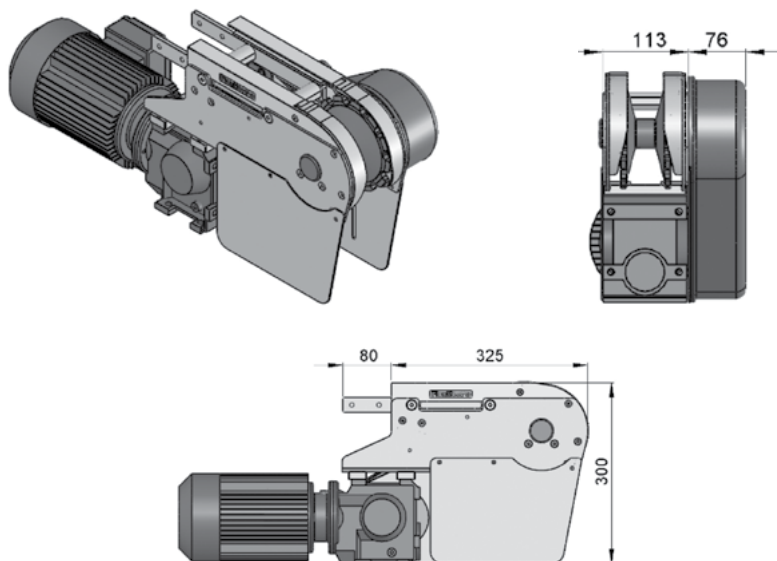

- Locates gearmotor below conveyor for compact applications.
- Includes torque limiter protecting chain and motor from overload.
- Chain pull capacity at 1250N for unit without torque limiter.
- Chain pull capacity at 840N for unit with torque limiter.

FC Suspended End Drive without Motor (RIGHT)

FCSD-A105-0R (with Torque Limiter)
FCSD-A105SPT-0R (without Torque Limiter)

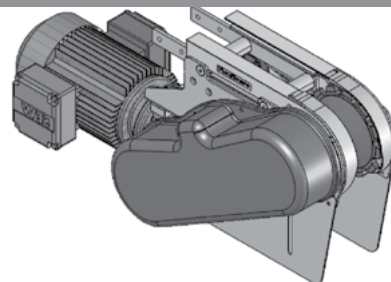

Max Traction Force:

1250N (without limiter)
800N (with limiter)

UOM: pc

Chain required 2-way: 0.8 meter
Slide rail required 2-way: 0.5 meter

FC Direct Intermediate Drive without Motor (LEFT)

FCID-DD-0L1

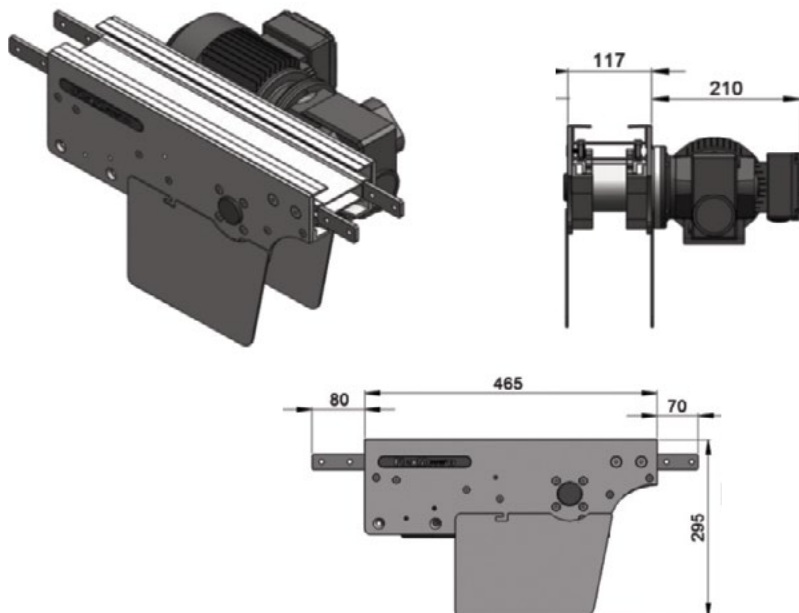

- Located in middle section of conveyor to free up drive end.

FC Direct Intermediate Drive without Motor (RIGHT)

FCID-DD-0R1

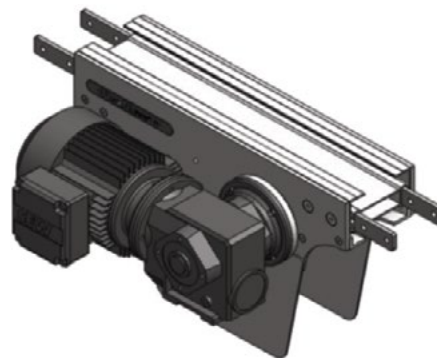

Max Traction Force: 200N

The Direct Intermediate Drive Unit is without torque limiter.

UOM: pc

Chain required 2-way: 0.8 meter
Slide rail required 2-way: 0.5 meter

SEW gearmotors are products of SEW Eurodrive

FC Suspended Intermediate Drive without Motor (LEFT)

FCID-SD -0L1

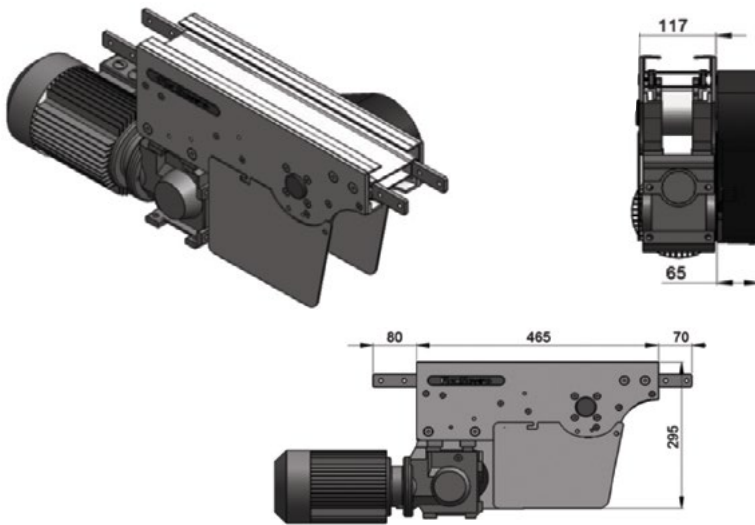

- Located in middle of conveyor to free up drive end.
- Includes torque limiter protecting chain and motor from overload.
- Limits chain pull capacity at 200N.

FC Suspended Intermediate Drive without Motor (RIGHT)

FCID-SD-0R1

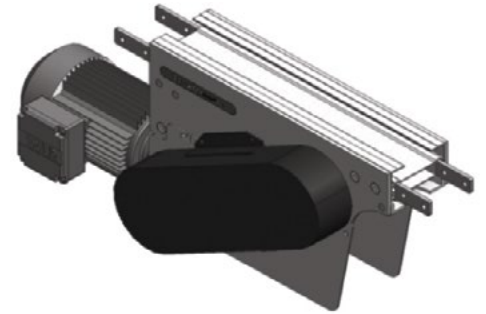

Max Traction Force: 200N

The Suspended Intermediate Drive Unit is with torque limiter.

UOM: pc

Chain required 2-way: 0.8 meter
Slide rail required 2-way: 0.5 meter

FC Combined Suspended Drive & Idler (LEFT)

FCCDI-SD-A105-0L

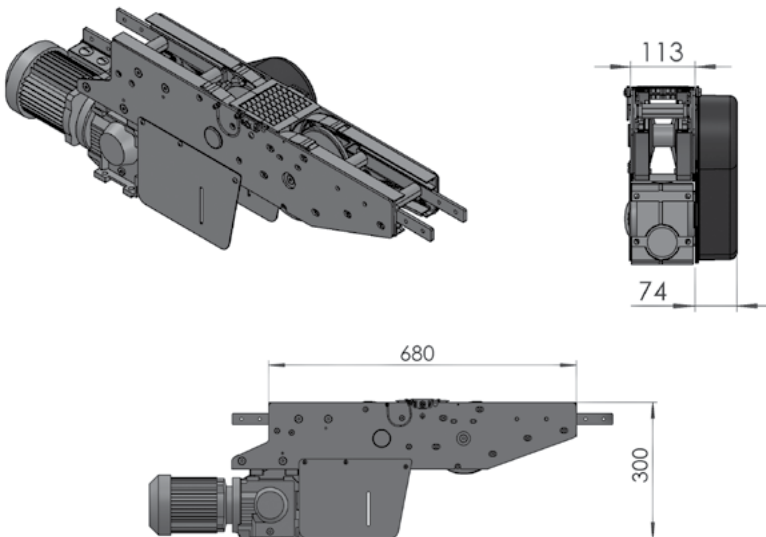

FC Combined Suspended Drive & Idler (RIGHT)

FCCDI-SD-A105-0R

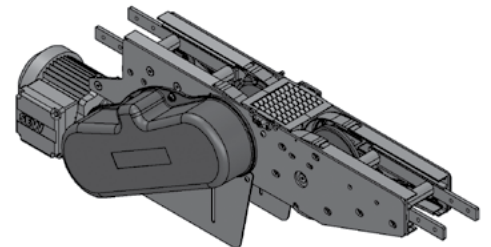

Max Traction Force: 800N

The Combine Suspended End Drive Unit is with torque limiter.

UOM: pc

Chain required 2-way: 1.6 meter
Slide rail required 2-way: 1.0 meter

SEW gearmotors are products of SEW Eurodrive

FC Suspended Catenary Drive without Motor (LEFT)

FCCD-SD-0L

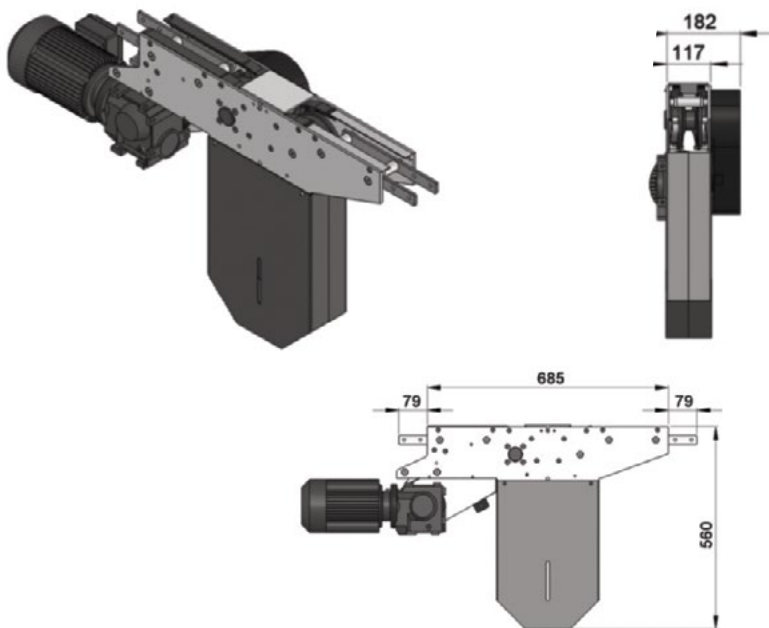

FC Suspended Catenary Drive without Motor (RIGHT)

FCCD-SD-0R

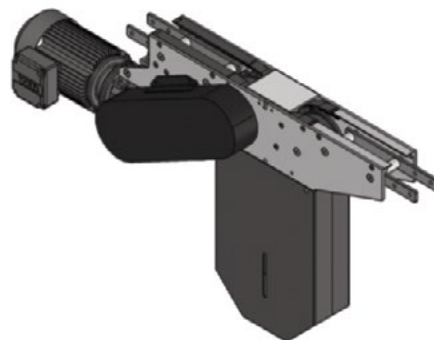

Max Traction Force: 800N

The Suspended Catenary Drive Unit is with torque limiter.

UOM: pc

Chain required 1-way: 1.4 meter

Slide rail required 1-way: 1.0 meter

FC Combined Direct Drive & Idler (LEFT)

FCCDI-DD-A105-0L

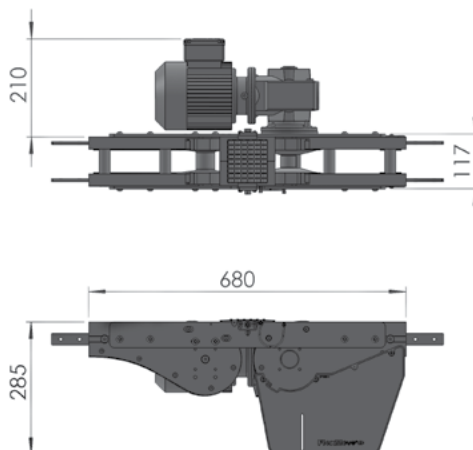
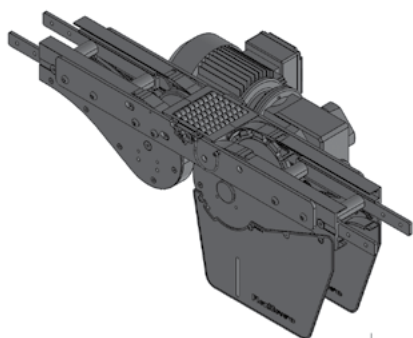

FC Combined Direct Drive & Idler (RIGHT)

FCCDI-DD-A105-0R

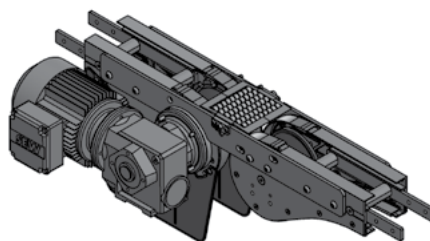

Max Traction Force: 1250N

The Combine Direct End Drive Unit is without torque limiter. Standard attached gearmotors are with SEW motor size 0.25kW, 0.37kW & 0.55kW. FCCDI-DD-A105-0L represents direct drive without gear motor.

UOM: pc

Chain required 2-way: 1.6 meter

Slide rail required 2-way: 1.0 meter

FC Weighted Take-up Module

FC-WTU-700

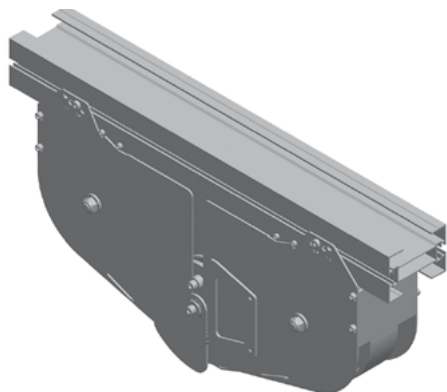

UOM: pc
Chain required 1.5 meter
Slide rail required 2.1 meter

- Provides automatic chain stretch take-up
- Reduces noise caused from catenary tail
- Must be used with GP Drive End, sold separately
- Used on conveyors over 12 M long

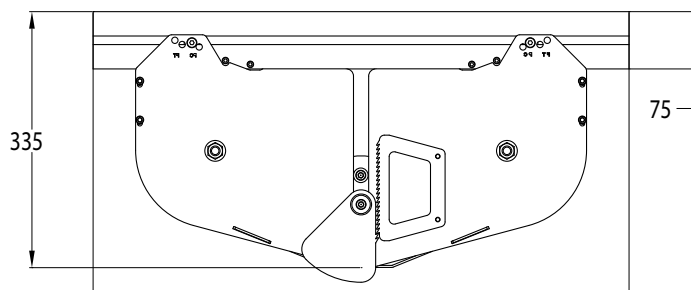
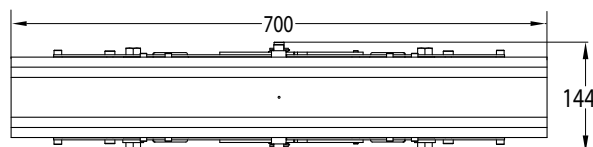

FC Weighted Take-up Tail Module

FC-WTU-105

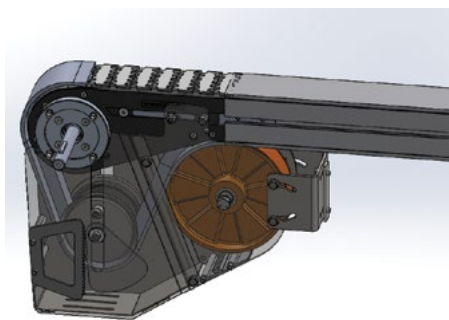
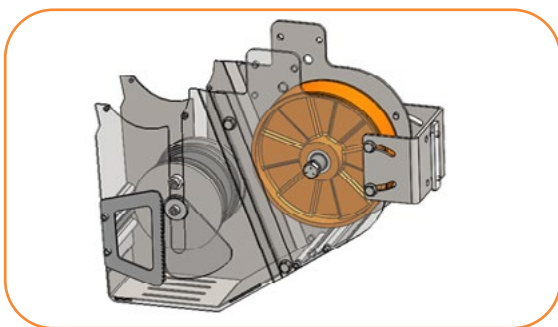

UOM: pc
Chain required 1.5 meter
Slide rail required 2.1 meter

- Provides controlled chain take-up for improved conveyor performance
- Compact design fits in similar space as standard direct drive modules
- Smooths conveyor chain movement by helping to eliminate micro-surfing
- Suggested for conveyors over 12.2 M (40 ft) in length
- Capable of inclined and declined arrangement up to 30 degrees
- Improves operator safety by enclosing chain catenary
- Attaches to direct end drive tail
- Compatible with power transfer and driven bridge

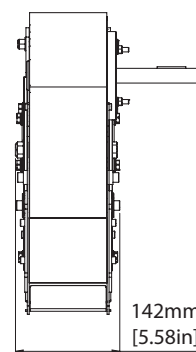
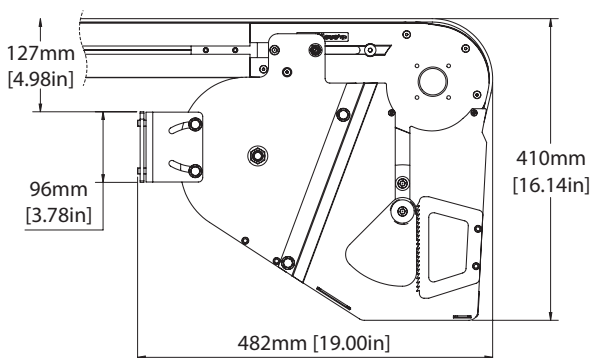
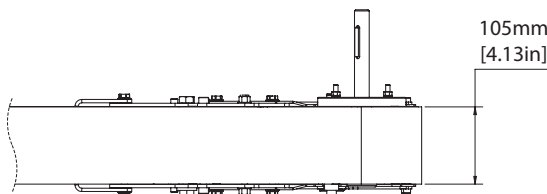

FC Top Running Drive Module

FCTRD-203

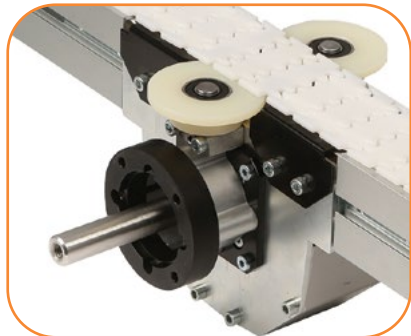

- For top running chain only
- 9M long conveyor length maximum
- 32 Kg load maximum
- Compatible with 3/4 inch shaft gearmotors only

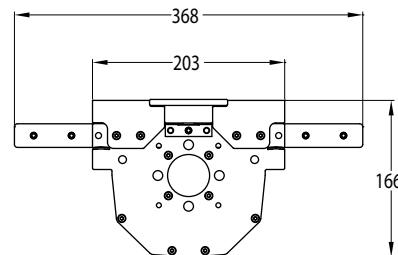
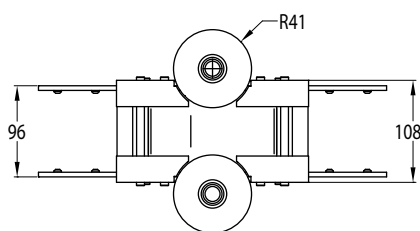
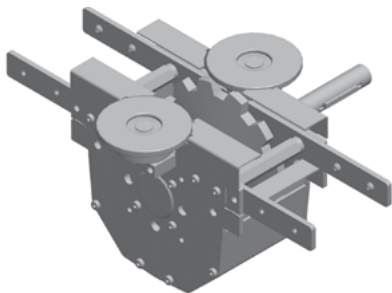

UOM: pc
Chain required 0.2 meter

FC Direct Wheel Drive without Motor

FCWD-DD-0M

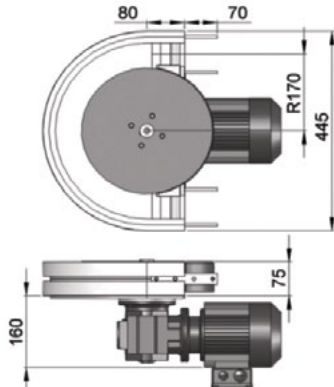

Max Traction Force: 200N

The Direct Wheel Drive Unit is without torque limiter. FCWD-DD-0M represents wheel drive without gear motor. Maximum traction force for FCWD-DD is lower than FCDD and FCSD.

UOM: pc
Chain required 1-way: 0.7 meter
Slide rail required 1-way: 0.7 meter

FC Suspended Wheel Drive without Motor

FCWD-SD-0M

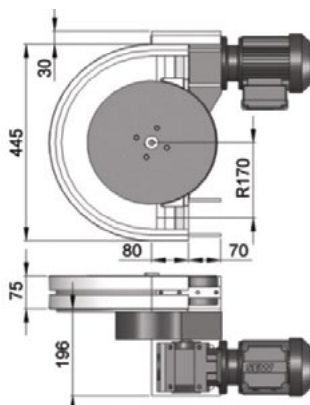
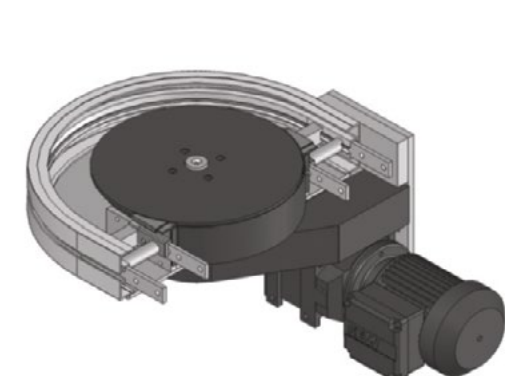

Max Traction Force: 200N

The Suspended Wheel Drive Unit is with torque limiter. FCWD-SD-0M represents wheel drive without motor. Maximum traction force for FCWD-SD is lower than FCDD and FCSD.

UOM: pc
Chain required 1-way: 0.7 meter
Slide rail required 1-way: 0.7 meter

SEW gearmotors are products of SEW Eurodrive

FC Idler End-105

FCIE-A105

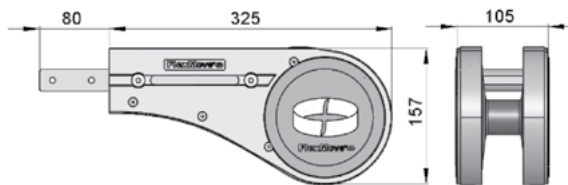
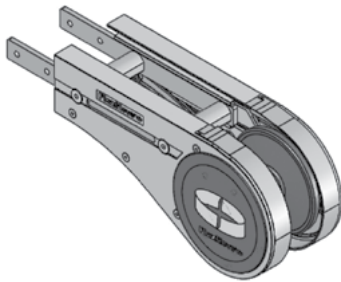

UOM: pc
Chain required 2-way: 0.8 meter
Slide rail required 2-way: 0.5 meter

FC Idler End with Power Transfer (LEFT)

FCIE-A105PT-L

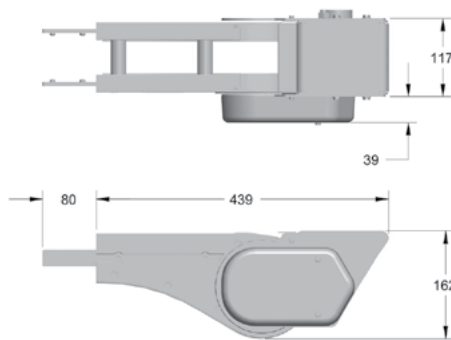
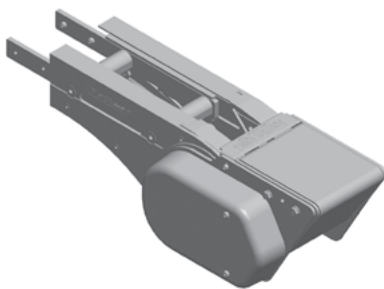

Minimum product length for inline transfer = 76 mm
Provides extended transfer nose for interfacing with large rollers.

FC Idler End with Power Transfer (RIGHT)

FCIE-A105PT-R

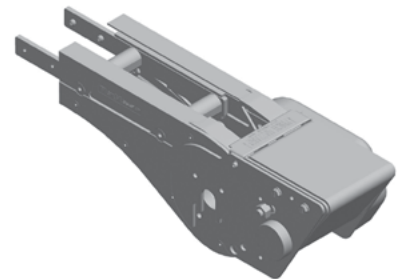

UOM: pc
Chain required 2-way: 0.8 meter
Slide rail required 2-way: 0.5 meter

FC Idler End Driven Transfer Bridge (LEFT)

FCIE-A105DB-A-L

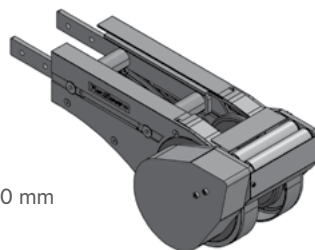
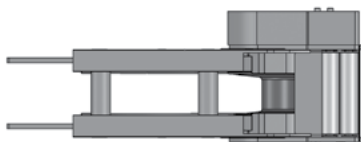

Minimum product length for inline transfer = 100 mm
Transfer extends past conveyor only 27 mm

UOM: pc
Chain required 2-way: 0.8 meter
Slide rail required 2-way: 0.5 meter

FC Direct Drive Driven Transfer Bridge (RIGHT)

FCIE-A105DB-A-R

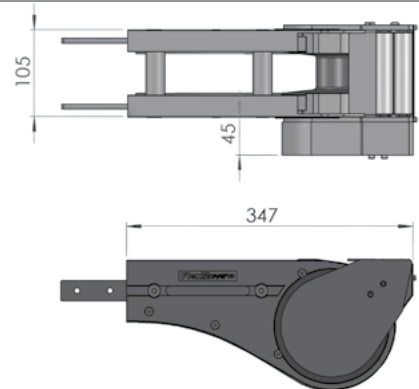

FC Idler Free Roller Transfer Bridge

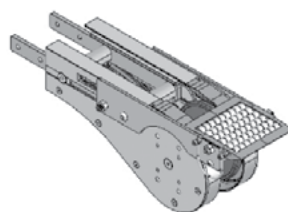
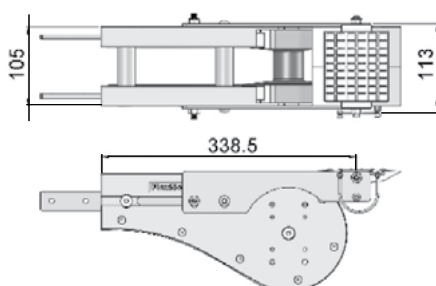

FCTB-A105

Transfer bridge c/w roller for FCIE-A105, FCDD-A105-XDY and FCDD-A105GP-XDY

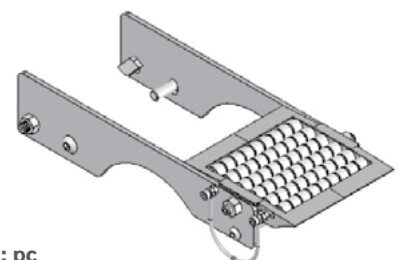

UOM: pc

FC Idler End Free Roller Bridge

FCEB-A105

End transfer bridge c/w roller for FCIE-A105, FCDD-A105-XDY and FCDD-A105GP-XDY

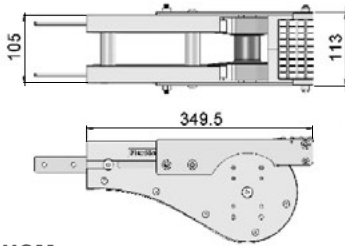

UOM: pc

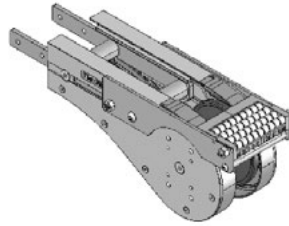

UOM: pc

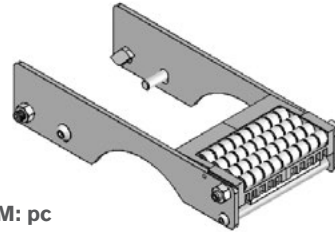

FC Idler End-308

FCIE-308B

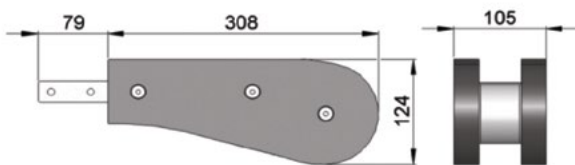

UOM: pc

Chain required 2-way: 0.8 meter
Slide rail required 2-way: 0 meter

FC Idler Bend

FCIB-350

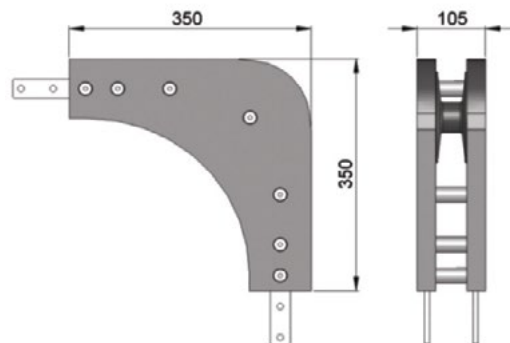

UOM: pc

Chain required 1-way: 0.6 meter
Slide rail: 0 meter

Note: Cannot be used with return chain

FC Wheel Bend 180°

FCWB-180R170A

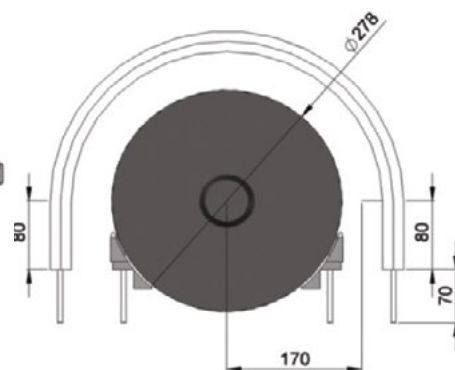
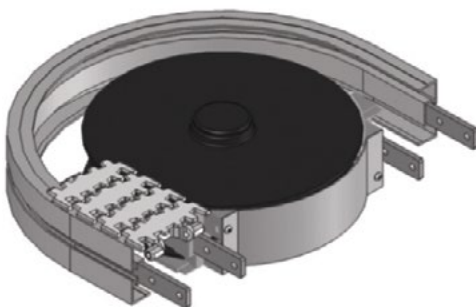

UOM: pc

Chain required 2-way: 1.4 meter
Slide rail required 2-way: 1.4 meter

SEW gearmotors are products of SEW Eurodrive

FC Wheel Bend 90°

FCWB-90R170A

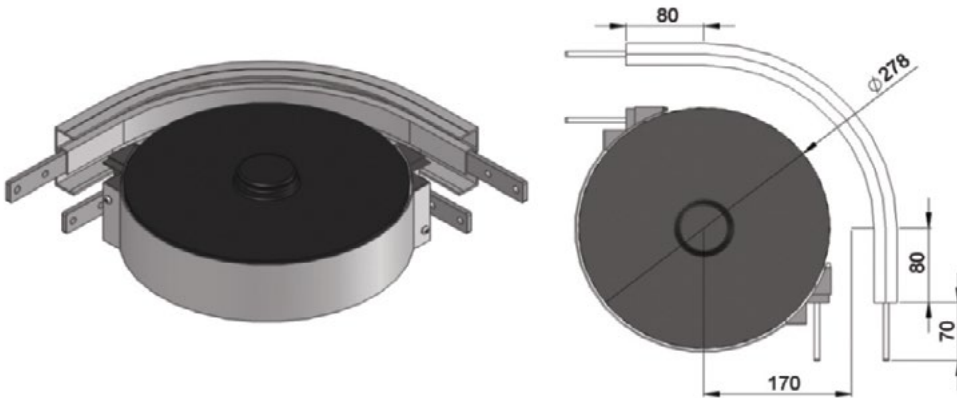

UOM: pc
 Chain required 2-way: 0.9 meter
 Slide rail required 2-way: 0.9 meter

FC Wheel Bend 60°

FCWB-60R170A

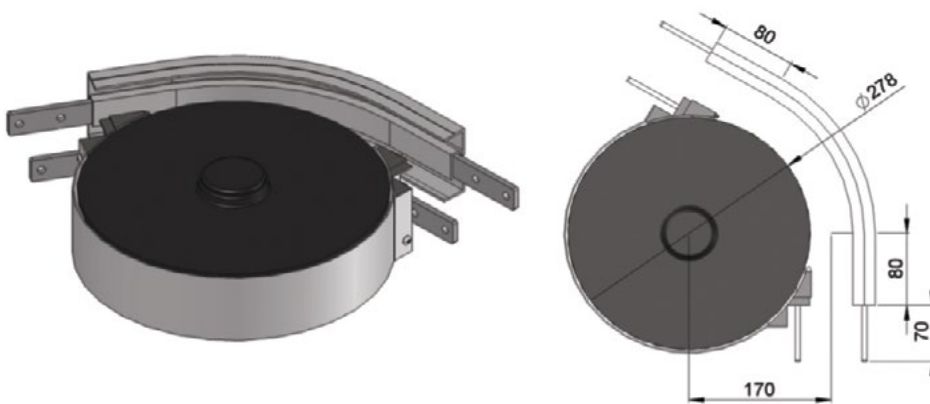

UOM: pc
 Chain required 2-way: 0.7 meter
 Slide rail required 2-way: 0.7 meter

FC Wheel Bend 45°

FCWB-45R170A

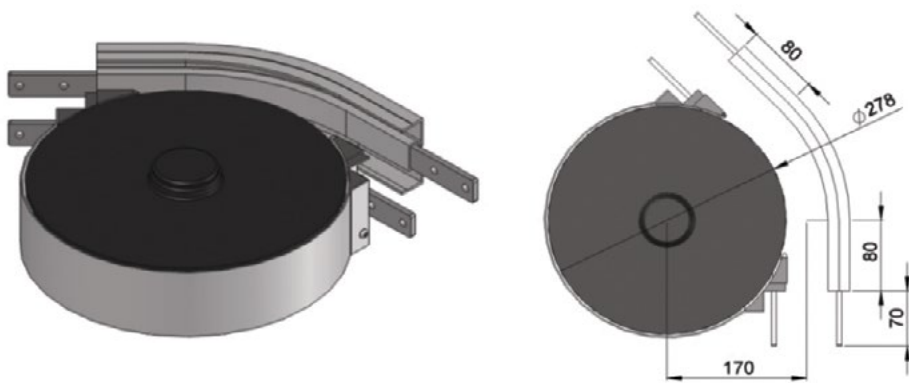

UOM: pc
 Chain required 2-way: 0.6 meter
 Slide rail required 2-way: 0.6 meter

FC Wheel Bend 30°

FCWB-30R170A

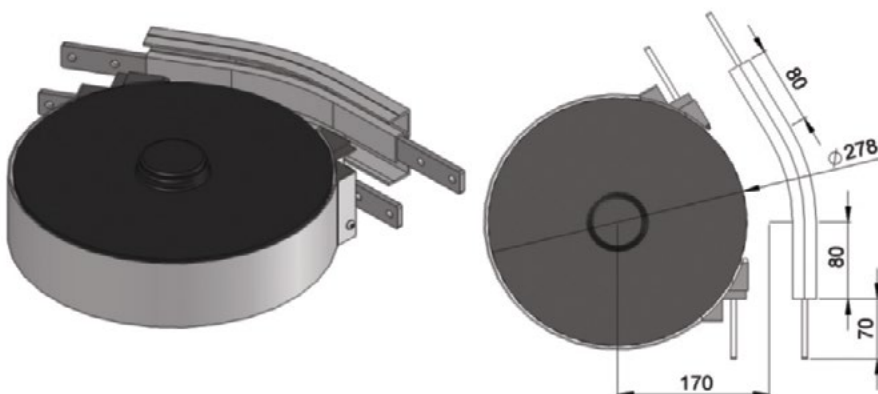

UOM: pc
 Chain required 2-way: 0.5 meter
 Slide rail required 2-way: 0.5 meter

FC Wheel Bend 5° - 180°

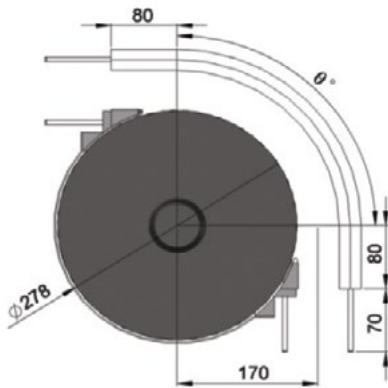

Example for FC Wheel Bend Ordering

- Wheel bend, $\varnothing \pm 1^\circ$
- FCWB- \varnothing° R170A

If an angle of 65° is needed for wheel bend, the ordering part number is

FCWB-65R170A

The outer bend is assembled using connecting strip (FACS-25x140A). Angle of \varnothing° must be indicated when ordering.

FC Horizontal Plain Bend 15°

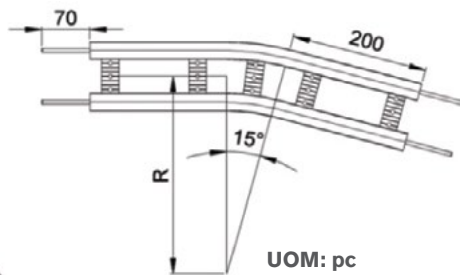

Horizontal plain bend, $15^\circ \pm 1^\circ$

R = 300 ± 10 mm	FCHB-15R300
R = 500 ± 10 mm	FCHB-15R500
R = 700 ± 10 mm	FCHB-15R700
R = 1000 ± 10 mm	FCHB-15R1000

UOM: pc

Chain required 2-way (300, 500, 700, 1000): 1, 1.1, 1.2, 1.3 meter
Slide rail required 2-way (300, 500, 700, 1000): 1.9, 2.1, 2.3, 2.6 meter

FC Horizontal Plain Bend 30°

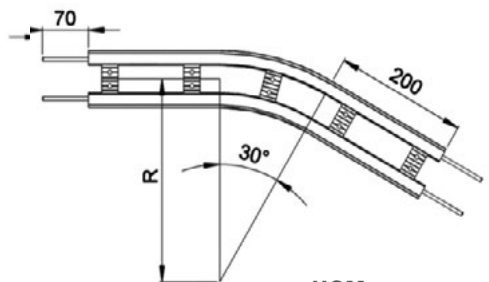

Horizontal plain bend, $30^\circ \pm 1^\circ$

R = 300 ± 10 mm	FCHB-30R300
R = 500 ± 10 mm	FCHB-30R500
R = 700 ± 10 mm	FCHB-30R700
R = 1000 ± 10 mm	FCHB-30R1000

UOM: pc

Chain required 2-way (300, 500, 700, 1000): 1.1, 1.3, 1.5, 1.8 meter
Slide rail required 2-way (300, 500, 700, 1000): 2.2, 2.6, 3.1, 3.7 meter

FC Horizontal Plain Bend 45°

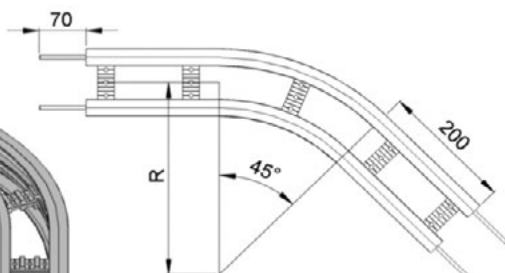
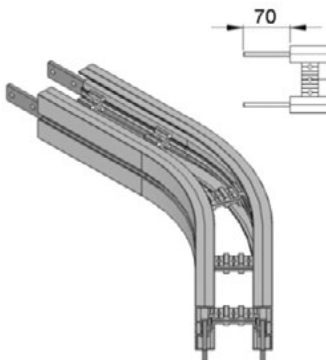

Horizontal plain bend, $45^\circ \pm 1^\circ$

R = 300 ± 10 mm	FCHB-45R300
R = 500 ± 10 mm	FCHB-45R500
R = 700 ± 10 mm	FCHB-45R700
R = 1000 ± 10 mm	FCHB-45R1000

UOM: pc

Chain required 2-way (300, 500, 700, 1000): 1.3, 1.6, 1.9, 2.4 meter
Slide rail required 2-way (300, 500, 700, 1000): 2.5, 3.2, 3.8, 4.7 meter

SEW gearmotors are products of SEW Eurodrive

FC Horizontal Plain Bend 60°

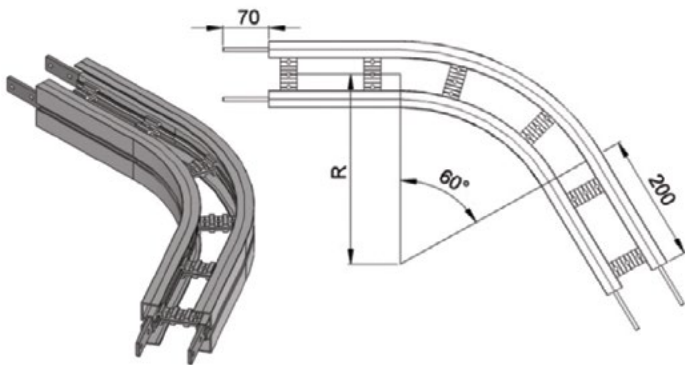

Horizontal plain bend, 60° ± 1°

R = 300 ± 10 mm	FCHB-60R300
R = 500 ± 10 mm	FCHB-60R500
R = 700 ± 10 mm	FCHB-60R700
R = 1000 ± 10 mm	FCHB-60R1000

UOM: pc

Chain required 2-way (300, 500, 700, 1000): 1.4, 1.8, 2.3, 2.9 meter
 Slide rail required 2-way (300, 500, 700, 1000): 2.9, 3.7, 4.5, 5.8 meter

SEW gearmotors are products of SEW Eurodrive

FC Horizontal Plain Bend 90°

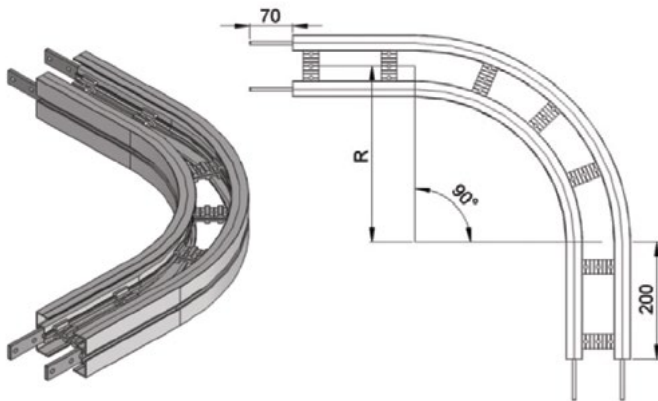

Horizontal plain bend, 90° ± 1°

R = 300 ± 10 mm	FCHB-90R300
R = 500 ± 10 mm	FCHB-90R500
R = 700 ± 10 mm	FCHB-90R700
R = 1000 ± 10 mm	FCHB-90R1000

UOM: pc

Chain required 2-way (300, 500, 700, 1000): 1.7, 2.4, 3.0, 3.9 meter
 Slide rail required 2-way (300, 500, 700, 1000): 3.5, 4.7, 6.0, 7.9 meter

FC Horizontal Plain Bend 180°

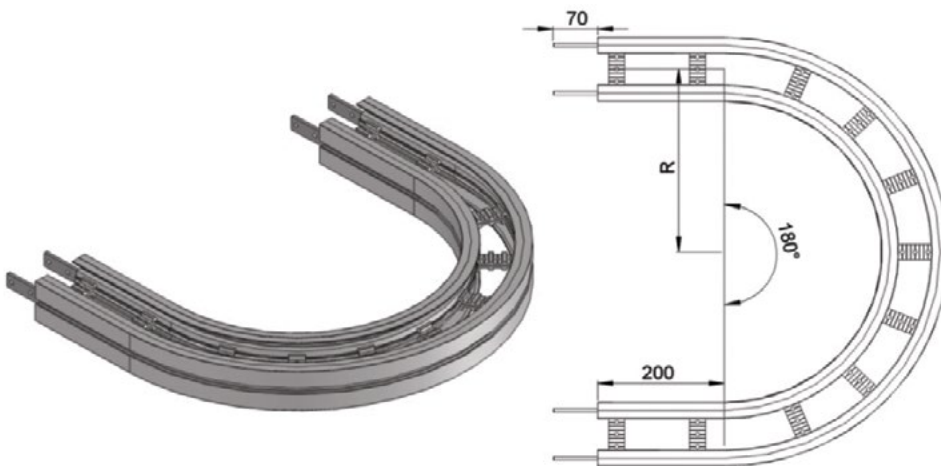

Horizontal plain bend, 180° ± 1°

R = 300 ± 10 mm	FCHB-180R300
R = 500 ± 10 mm	FCHB-180R500
R = 700 ± 10 mm	FCHB-180R700
R = 1000 ± 10 mm	FCHB-180R1000

UOM: pc

Chain required 2-way (300, 500, 700, 1000) : 2.7, 4.0, 5.2, 7.1 meter
 Slide rail required 2-way(300, 500, 700, 1000): 5.4, 7.9, 1.1, 14.2 meter

FC Horizontal Plain Bend 5° - 180°

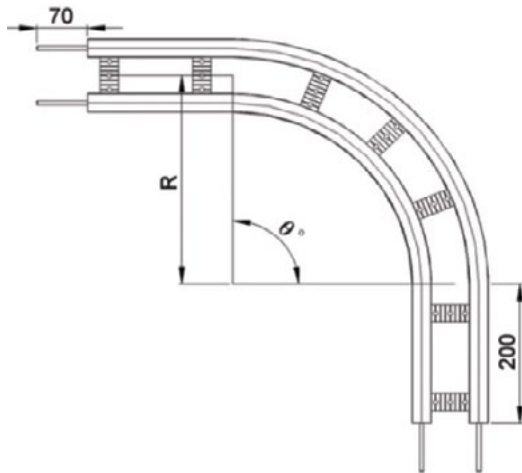

Example for FC Horizontal Plain Bend Ordering

Horizontal plain bend, $\theta^\circ \pm 1^\circ$

R = 300 ± 10 mm	FCHB- θ°R300
R = 500 ± 10 mm	FCHB- θ°R500
R = 700 ± 10 mm	FCHB- θ°R700
R = 1000 ± 10 mm	FCHB- θ°R1000

If an angle of 120° is needed for radius R500 horizontal plain bend, the ordering part number is

FCHB-120R500

UOM: pc

Chain required 2-way (300, 500, 700, 1000) : meter (variable to angle)
Slide rail required 2-way(300, 500, 700, 1000): meter (variable to angle)

FC Vertical Bend 5°

FCVB-5R400

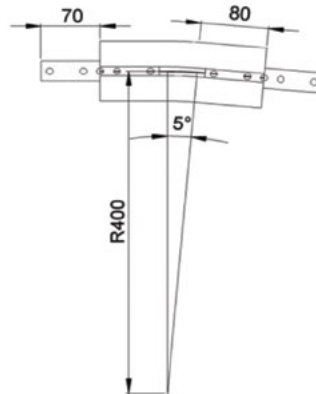
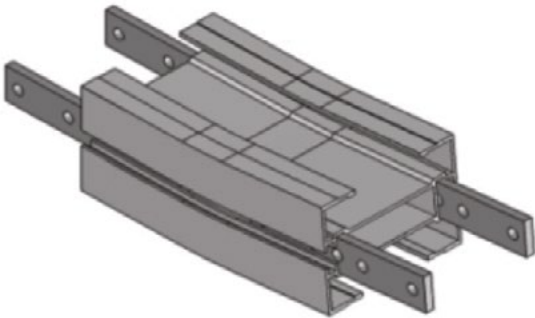

UOM: pc

Chain required 2-way: 0.4 meter
Slide rail required 2-way: 0.8 meter

FC Vertical Bend 10°

FCVB-10R400

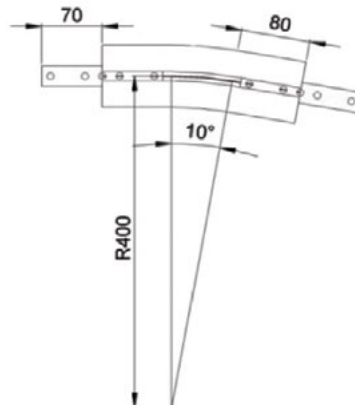
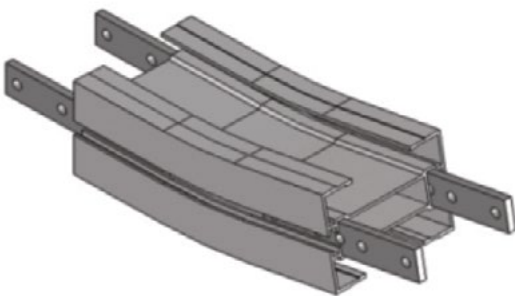

UOM: pc

Chain required 2-way: 0.5 meter
Slide rail required 2-way: 0.9 meter

FC Vertical Bend 15°

FCVB-15R400

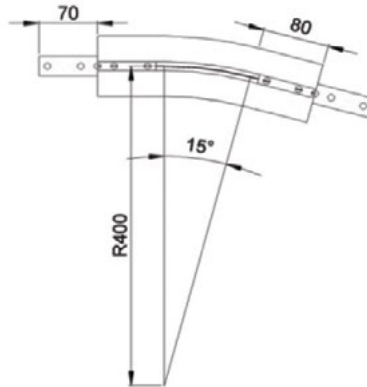
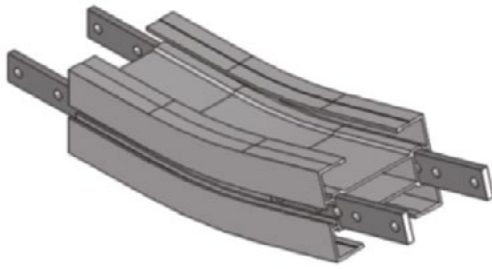

UOM: pc

Chain required 2-way: 0.5 meter
Slide rail required 2-way: 1.1 meter

FC Vertical Bend 20°

FCVB-20R400

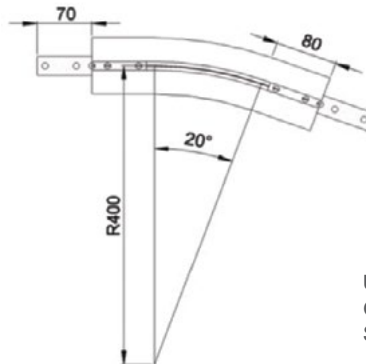
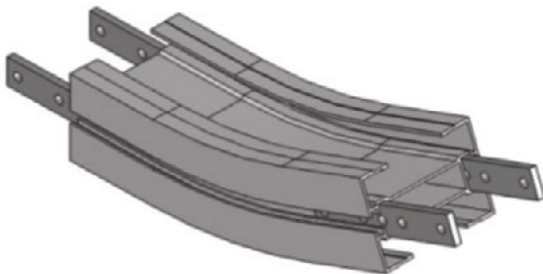

UOM: pc

Chain required 2-way: 0.6 meter
Slide rail required 2-way: 1.2 meter

FC Vertical Bend 30°

FCVB-30R400

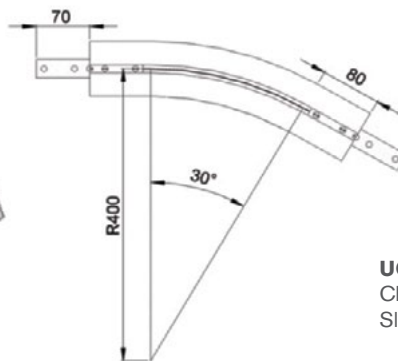
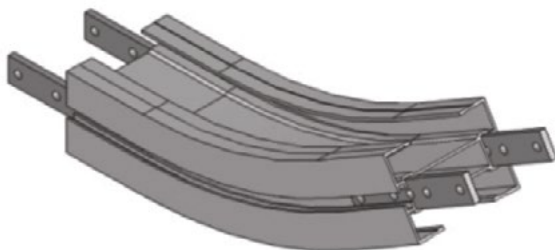

UOM: pc

Chain required 2-way: 0.7 meter
Slide rail required 2-way: 1.5 meter

FC Vertical Bend 45°

FCVB-45R400

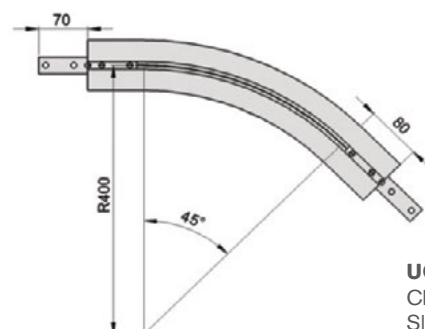
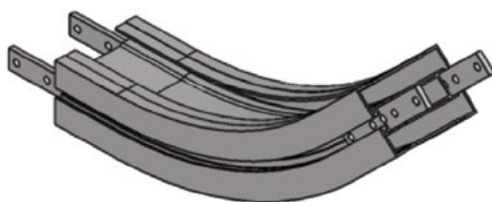

UOM: pc

Chain required 2-way: 0.9 meter
Slide rail required 2-way: 1.9 meter

FC Vertical Bend 60°

FCVB-60R400

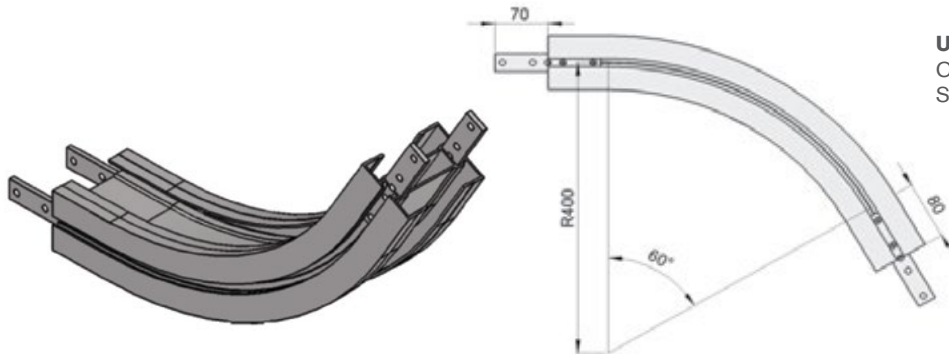

UOM: pc

Chain required 2-way: 1.2 meter
Slide rail required 2-way: 2.3 meter

FC Vertical Bend 90°

FCVB-90R400

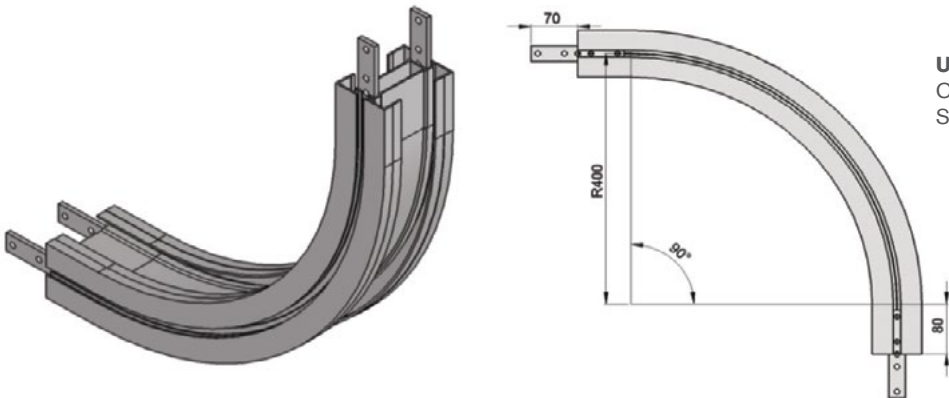

UOM: pc

Chain required 2-way: 1.6 meter
Slide rail required 2-way: 3.2 meter

FC Vertical Bend 5° - 90°

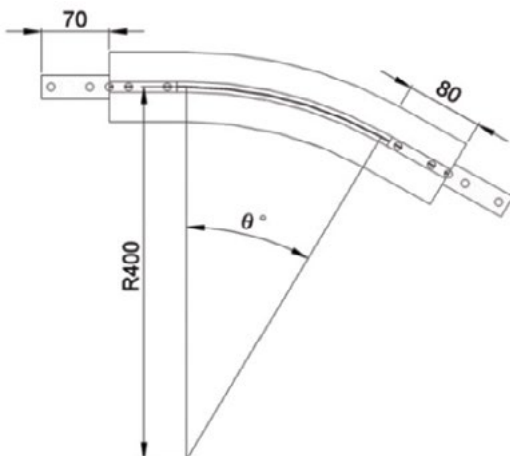

Example for FC Vertical Bend Ordering

- Vertical bend, $\varnothing^\circ \pm 1^\circ$
- FCVB- \varnothing° R400

If an angle of 65° is needed for vertical bend, the ordering part number is

FCVB-65R400

The outer bend is assembled using connecting strip (FACS-25x140A). Angle of "Ø°" must be indicated when ordering.

FC 45 Degree Twist Conveyor Beam (Clockwise)

FCTB-CW45x3000

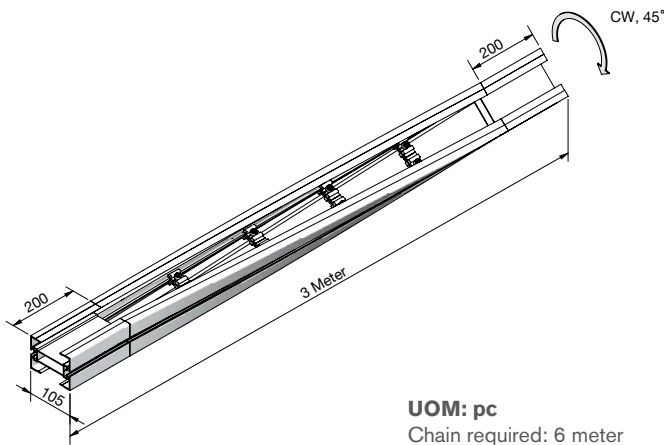

UOM: pc
Chain required: 6 meter
Slide rail required: 12 meter

FC 45 Degree Twist Conveyor Beam (Counter-Clockwise)

FCTB-CCW45x3000

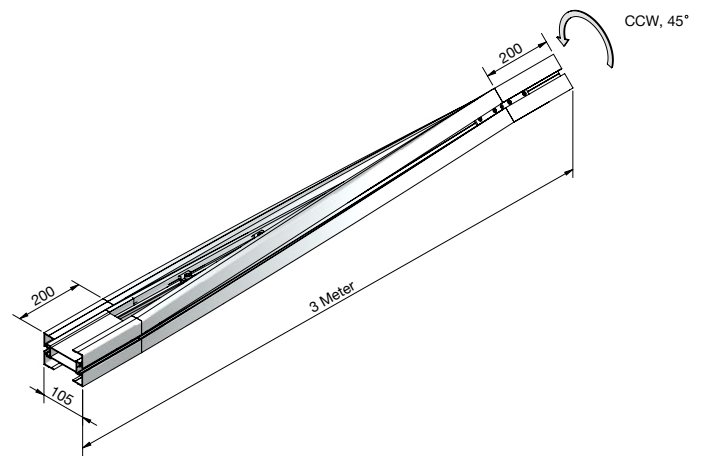

FC 90 Degree Twist Conveyor Beam (Clockwise)

FCTB-CW90x3000

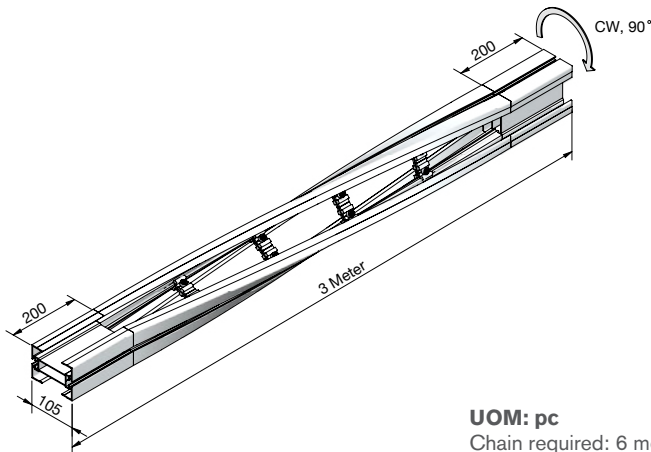

UOM: pc
Chain required: 6 meter
Slide rail required: 12 meter

FC 90 Degree Twist Conveyor Beam (Counter-Clockwise)

FCTB-CCW90x3000

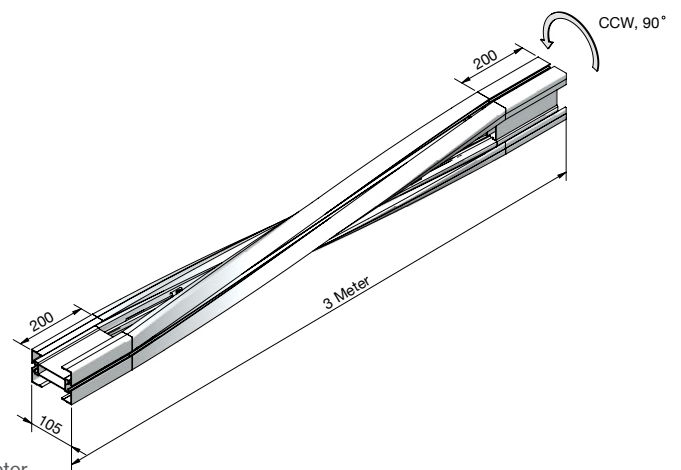

FC Twist Conveyor Beam 15° - 90°

FCTB-AAABx3000

Where AAA = CW or CCW, BB = Angle

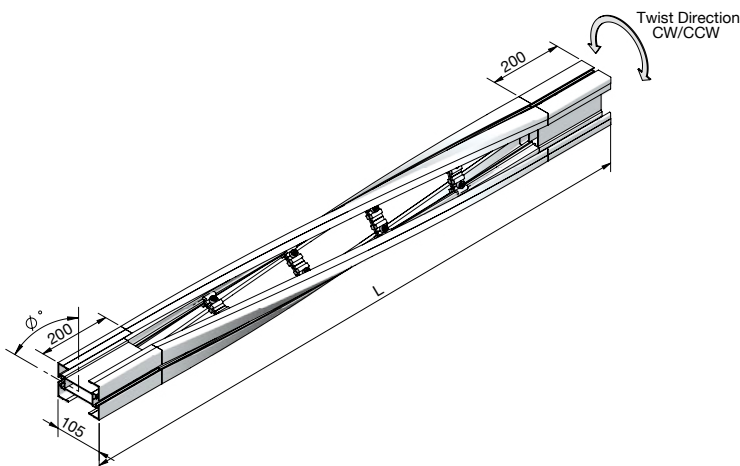

Example for FC Twist Conveyor Beam Ordering

- Twist Conveyor Beam, $\emptyset^\circ \pm 5^\circ$

If an angle of 30° is needed for twist beam, in clockwise direction and length 3.0 m, the ordering part number is

FCTB-CW30x3000

Angle of \emptyset° , twist direction, and length L , must be indicated when ordering.

UOM: pc
Chain required: 6 meter
Slide rail required: 12 meter

FC S In-Line Transfer Module

FCST-105

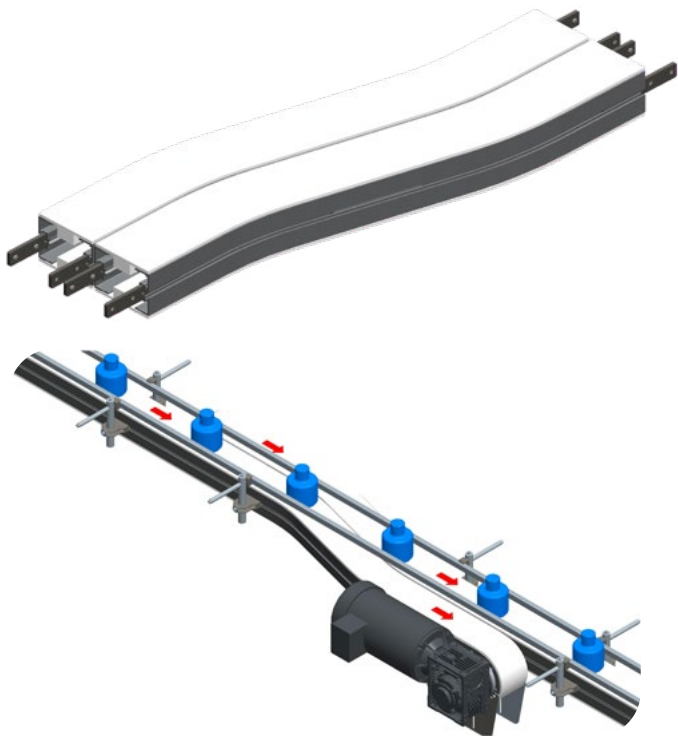

- S In-Line Modules provide a standard, compact way to side transfer product from conveyor to conveyor.
- Straight guiding is placed across the transfer module for smooth In-Line product flow
- Conveyors are mounted together to provide a smooth transfer even for small products
- S In-Line transfers are compact in the width dimension

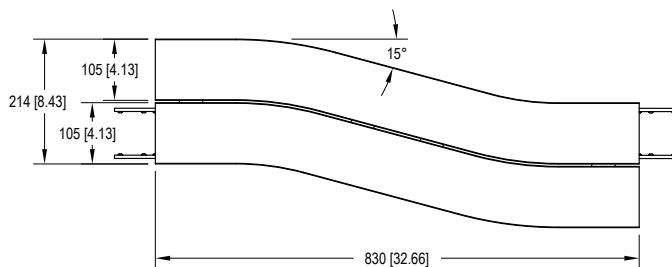

FC X In-Line Transfer Module

FCXT-105

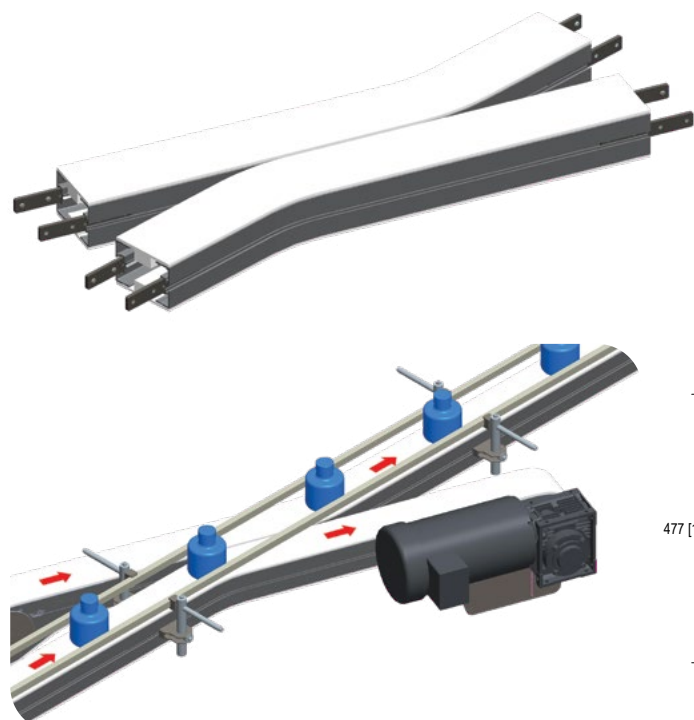

- X In-Line Modules provide a standard, compact way to side transfer product from conveyor to conveyor.
- Straight guiding is placed across the transfer module for smooth In-Line product flow
- Conveyors are mounted together to provide a smooth transfer even for small products
- X In-Line transfers are compact in the length direction

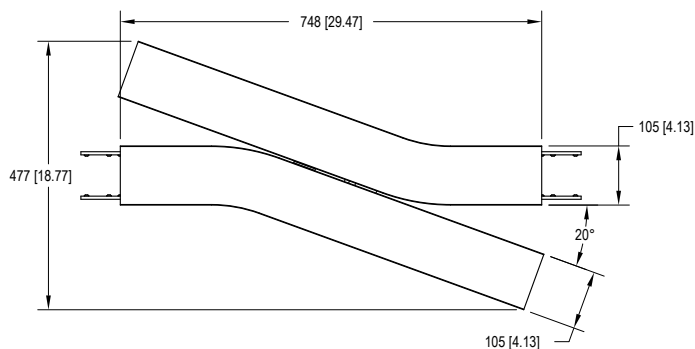

Variety of chain type suitable for wide range of applications either horizontal or vertical product transportation. Capacity higher than FK, FS, FM. The maximum product width to be conveyed can be referred to guide rail assembly pages.

FL Series Characteristic

Beam Width: 150 mm

Product Width: Refer to Guide Rail Assembly

Accessories Needed

Slide Rail Required: FASR-25 OR FASR-25U

Slide Rail Color: White or Natural Color

Slide Rail Material: HDPE OR UHMW

Slide Rail Rivet & Screw: FASLR-4X6 or FASLS-M5

Connecting strip is used to connect two beams.

Connecting Strip: FACS-25x140A

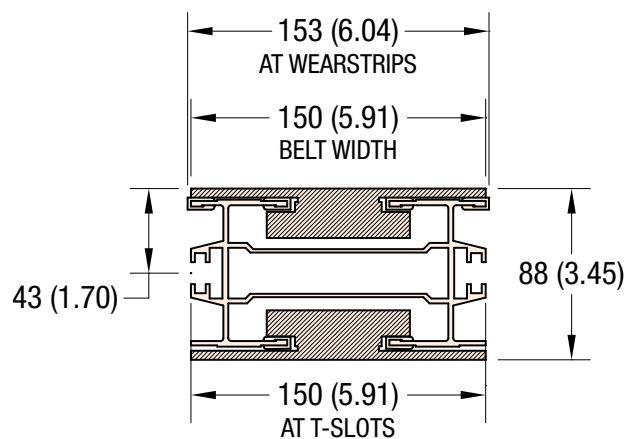

150 MM WIDTH

Conveyor Beam **FLCB-3**

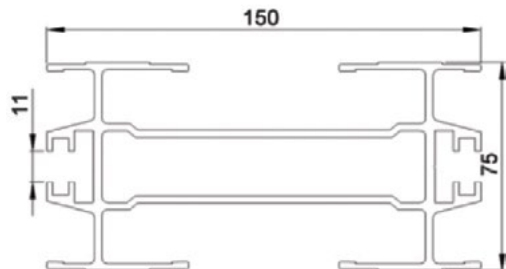

UOM: 3 Meter / Length

Chain Connecting Module **FLCC-160**

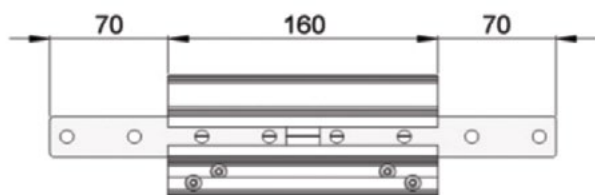

UOM: pc

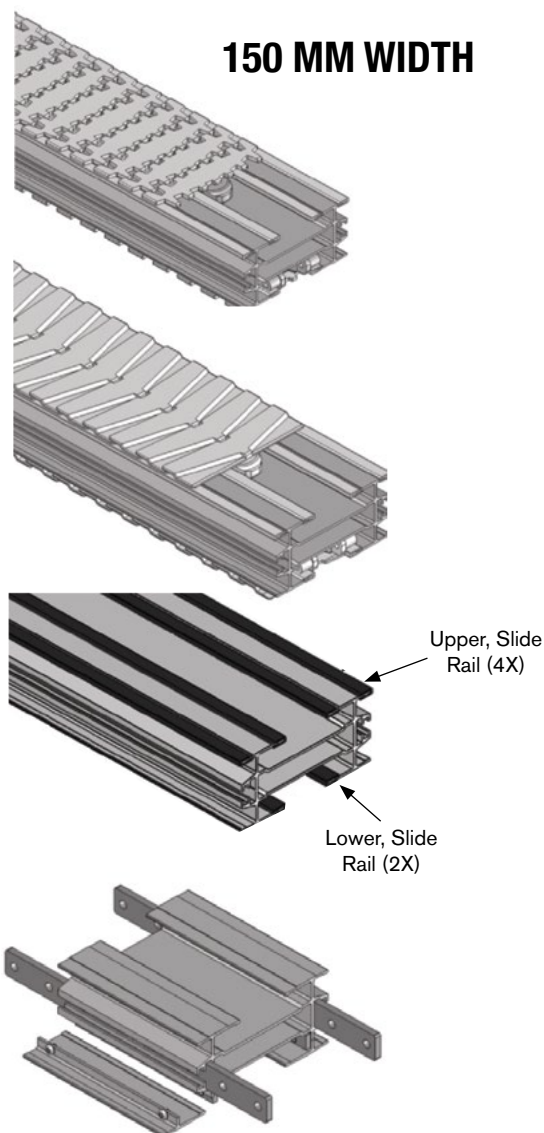

Chain Common Data

Packaging: 5 m per box

Pitch: 35.5 mm

Width: 150 mm

Tensile Strength at 20°C: 6000N

Color: White & Black (Conductive)

Material:

Chain: White Acetal / POM

Pivot: Polyamide

Pivot Pin: Stainless Steel

Insert (Wedge & Friction): TPE Grey

Example for FLRC-5B-L#

= 1 cleated top chain with alternate of # link of plain chain

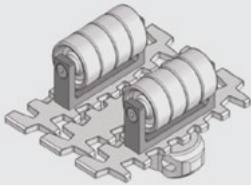

The above chain is FLRC-5B-L1, 1 link cleated top chain with alternate of 1 link of plain chain.

Note: # = 1, 2, 3, 4, 5.....20

Standard Plain Chain **FLPC-5**

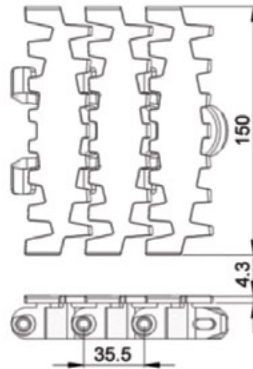
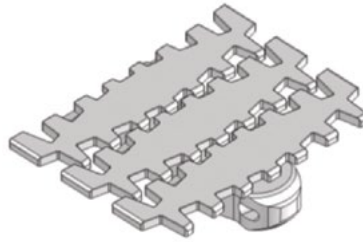

UOM: 5 Meter / box

Application: Suitable for horizontal and slope <math>< 5^\circ</math> transport of products with accumulation.

Conductive Chain **FLPC-5CD**

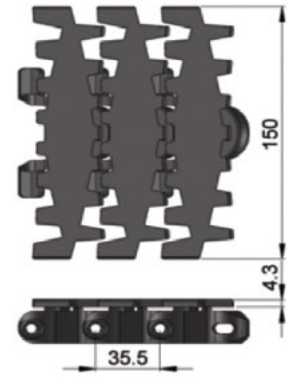
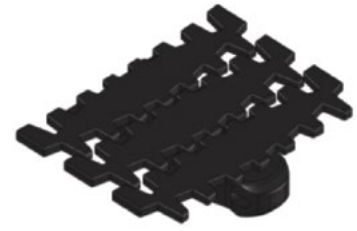

UOM: 5 Meter / box

Application: Suitable for transport of static sensitive product.



Friction Top Chain **FLFT-5**

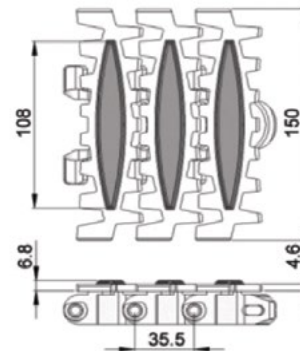
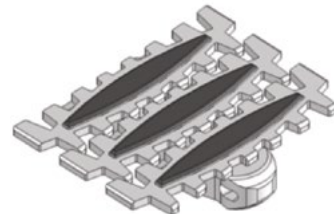

UOM: 5 Meter / box

Application: Suitable for transport product in slope > \leq 30^\circ</math> without accumulation.

Roller Top Chain **FLRT-5V**

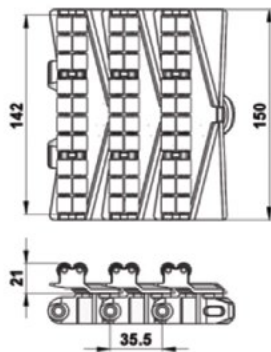
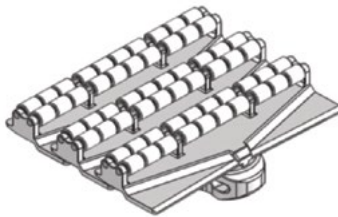

UOM: 5 Meter / box

Application: Suitable for accumulation of product with low friction and pressure.

Roller Cleat Chain **FLRC-5A-L#**

= 1, 2, 3, 4, 5.....20

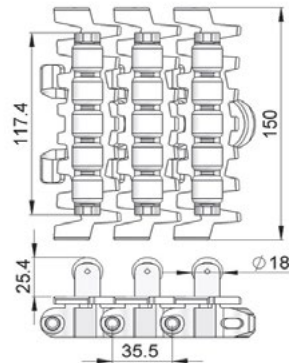
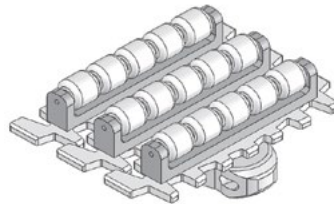

UOM: 5 Meter / box

Application: Suitable for vertical transportation of product in slope with no accumulation.

Roller Cleat Chain **FLRC-5B-L#**

= 1, 2, 3, 4, 5.....20

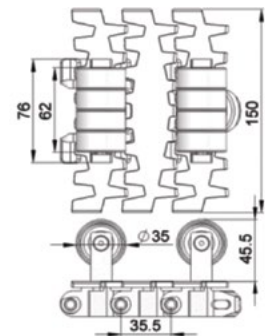
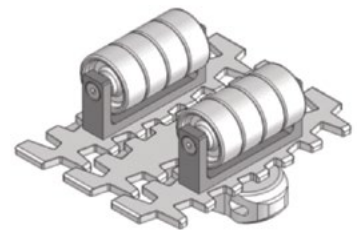

UOM: 5 Meter / box

Application: Suitable for vertical transportation of product in slope with no accumulation.

Cleat Top Chain **FLCT-5A30-L#**

= 1, 2, 3, 4, 5.....20

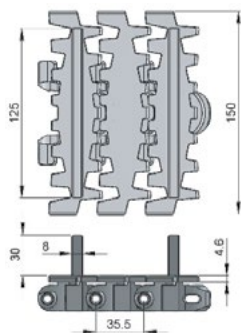
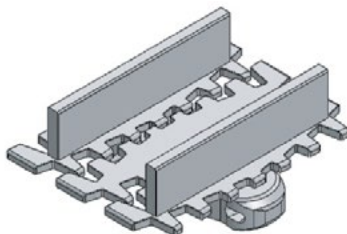

UOM: 5 Meter / box

Application: Suitable for vertical transportation of product in slope with no accumulation.

Safety Chain-V **FLPC-5V**

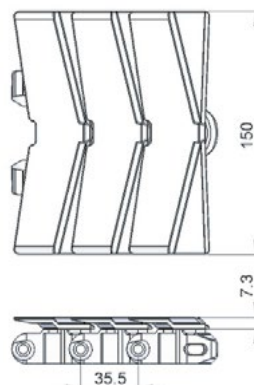
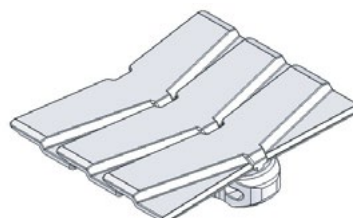

UOM: 5 Meter / box

Application: (Safety Chain) Suitable for horizontal and slope <math>< 5^\circ</math> transport of products with accumulation.

Safety Chain Friction Top **FLFT-5V**

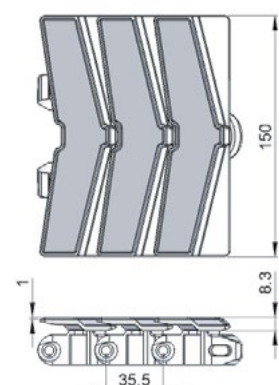
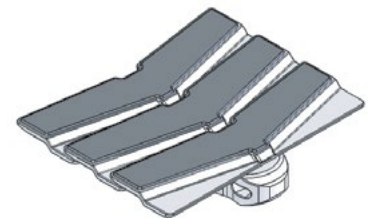

UOM: 5 Meter / box

Application: (Safety Chain) Suitable for transport product in slope >math>5^\circ</math> but $\le 30^\circ</math> without accumulation.$

SEW gearmotors are products of SEW Eurodrive

FL Direct End Drive without Motor (LEFT)

FLDD-A150-XDY (See Chart)

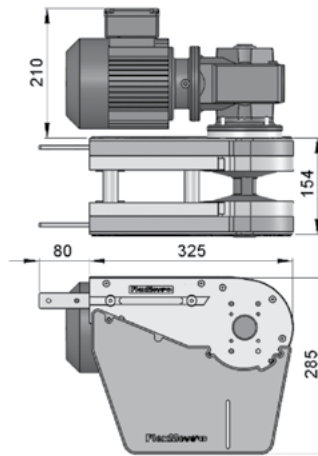
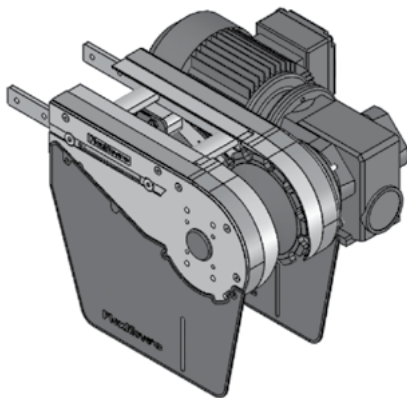

FL Direct End Drive without Motor (RIGHT)

FLDD-A150-XDY (See Chart)

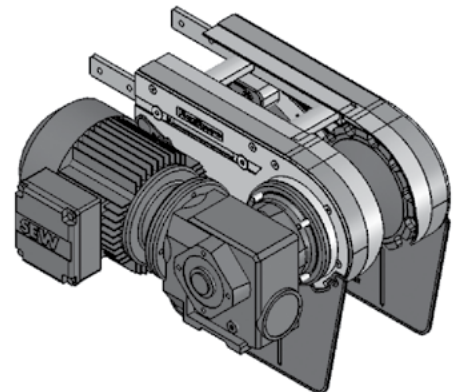

Part Number		Shaft Selection	Direction	Aux Shaft Selection
FLDD-A150	-	X	D	Y
		0 = 20 mm	L = Left	Blank = No Aux Shaft
		E = 3/4 in*	R = Right	A = 20 mm Aux Shaft
		A = 20 mm Aux Only		

*3/4 inch shaft option available in North America only.

Max Traction Force: 1250N

The Direct End Drive Unit is without torque limiter.

UOM: pc

Chain required 2-way: 0.8 meter
Slide rail required 2-way: 0.5 meter

FL Direct End Drive unit without Motor GP (LEFT)

FLDD-A150GP-XDY (See Chart)

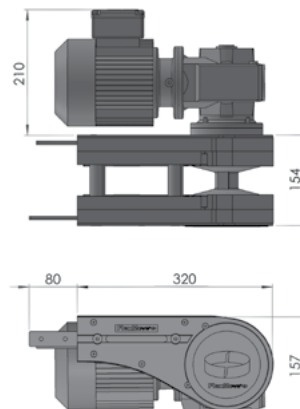
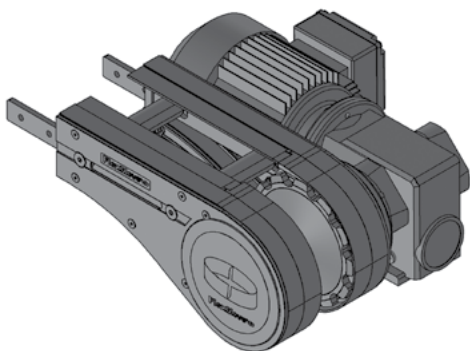

FL Direct End Drive unit without Motor GP (RIGHT)

FLDD-A150GP-XDY (See Chart)

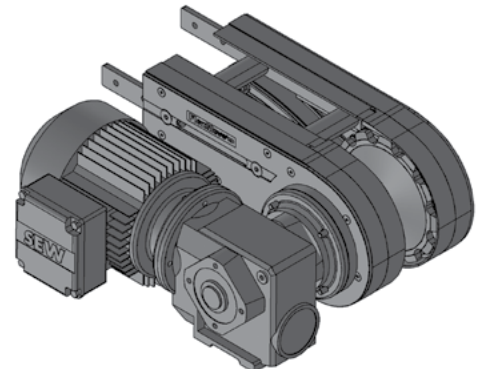

Requires the use of connecting or weighted take-up module for chain maintenance.

Part Number		Shaft Selection	Direction	Aux Shaft Selection
FLDD-A150GP	-	X	D	Y
		0 = 20 mm	L = Left	Blank = No Aux Shaft
		E = 3/4 in*	R = Right	A = 20 mm Aux Shaft
		A = 20 mm Aux Only		

*3/4 inch shaft option available in North America only.

Max Traction Force: 1250N

The Direct End Drive Unit GP is without torque limiter.

UOM: pc

Chain required 2-way: 0.8 meter
Slide rail required 2-way: 0.5 meter

SEW gearmotors are products of SEW Eurodrive

FL Direct with Power Transfer Motor (LEFT)
FLDD - A150PT-XD (See Chart)

FL Direct with Power Transfer Motor (RIGHT)
FLDD - A150PT-XD (See Chart)

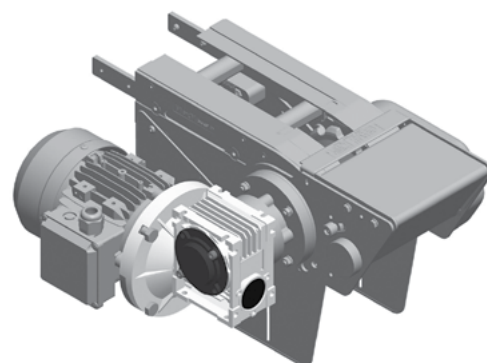
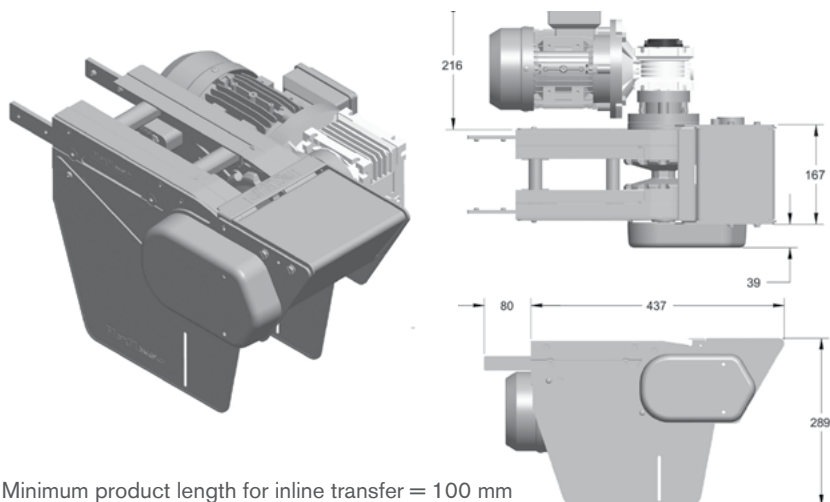

Minimum product length for inline transfer = 100 mm
 Maximum speed is 30 m/min (100 ft/min)
 Only one power transfer needed on either infeed or discharge trail required for end to end transfer. Provides extended transfer nose for interfacing with large rollers.

Part Number		Shaft Selection	Direction
FLDD-A150PT	-	X	D
		0 = 20 mm	L = Left
		E = 3/4 in*	R = Right

*3/4 inch shaft option available in North America only.

Max Traction Force: 1250N
 The Direct End Drive Unit is without torque limiter.

UOM: pc
 Chain required 2-way: 0.8 meter
 Slide rail required 2-way: 0.5 meter

FL GP Direct with Power Transfer Motor (LEFT)
FLDD-A150GPPT-XD (See Chart)

FL GP Direct with Power Transfer Motor (RIGHT)
FLDD-A150GPPT-XD (See Chart)

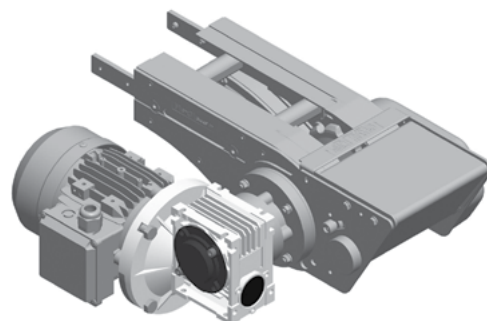
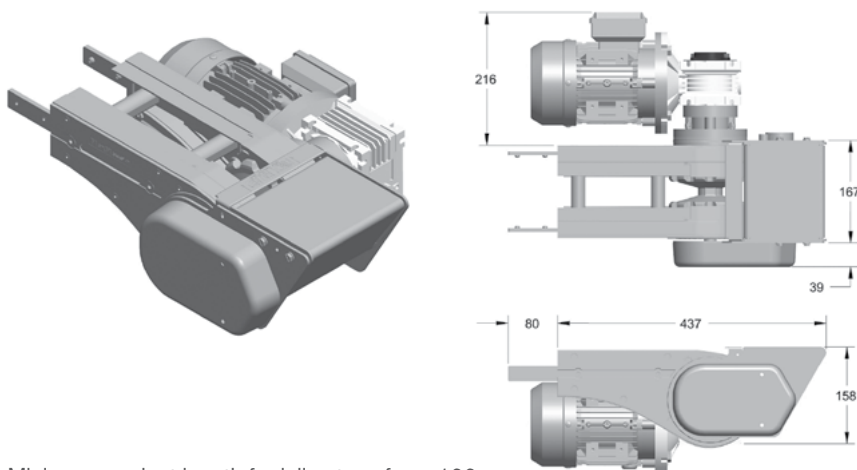

Minimum product length for inline transfer = 100 mm
 Maximum speed is 30 m/min (100 ft/min)
 Only one power transfer needed on either infeed or discharge trail required for end to end transfer. Provides extended transfer nose for interfacing with large rollers. Requires the use of connecting or weighted take-up module for chain maintenance.

Part Number		Shaft Selection	Direction
FLDD-A150GPPT	-	X	D
		0 = 20 mm	L = Left
		E = 3/4 in*	R = Right

*3/4 inch shaft option available in North America only.

Max Traction Force: 1250N
 The Direct End Drive Unit GP is without torque limiter.

UOM: pc
 Chain required 2-way: 0.8 meter
 Slide rail required 2-way: 0.5 meter

SEW gearmotors are products of SEW Eurodrive

FL Direct Drive Driven Transfer Bridge (LEFT)

FLDD-A150DB-A-0L

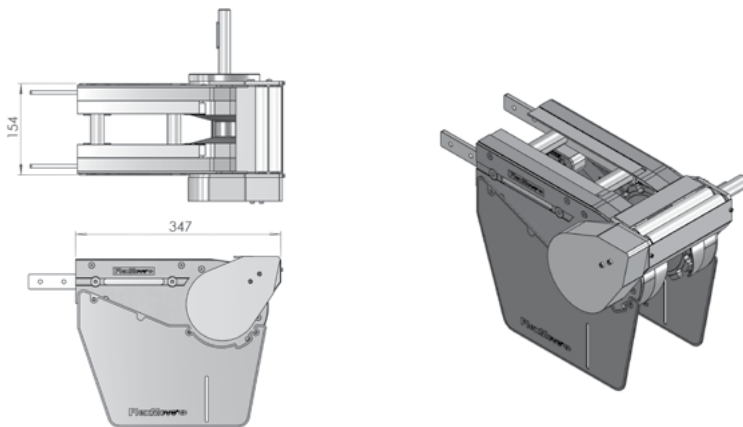

UOM: pc

20 mm Shaft only.

Minimum product length for inline transfer = 100 mm

Transfer extends past conveyor only 27 mm

FL Direct Drive Driven Transfer Bridge (RIGHT)

FLDD-A150DB-A-0R

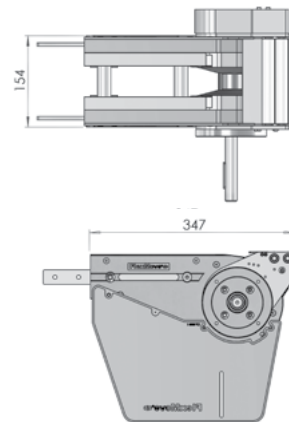

Max Traction Force: 1250N

The Direct End Drive Unit is without torque limiter.

UOM: pc

Chain required 2-way: 0.8 meter

Slide rail required 2-way: 0.5 meter

FL Direct Drive Free Roller Transfer Bridge (LEFT/RIGHT)

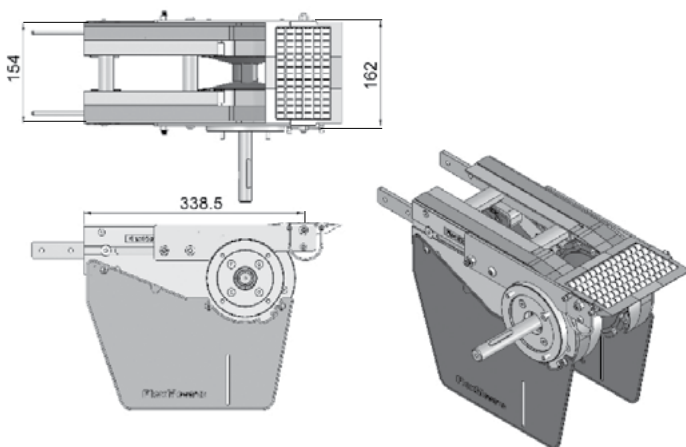

FLTB-A150

Transfer bridge c/w roller for FLIE-A150

Transfer bridge c/w roller for FLDD-A150-0L

Transfer bridge c/w roller for FLDD-A150-0R

UOM: pc

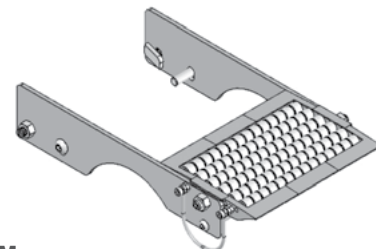

FL Idler End Free Roller Bridge

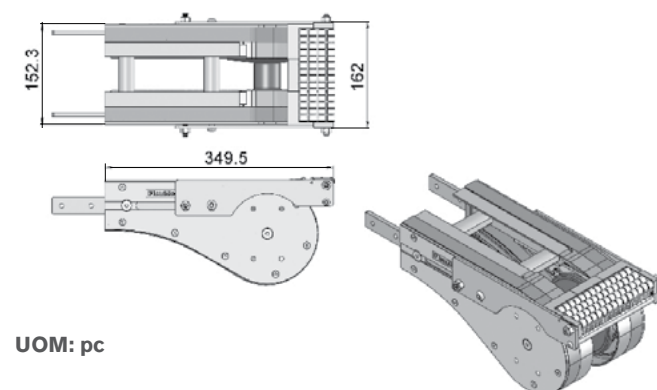

UOM: pc

FLEB-A150

End transfer bridge c/w roller for FLIE-A150

End transfer bridge c/w roller for FLDD-A150-0L

End transfer bridge c/w roller for FLDD-A150-0R

UOM: pc

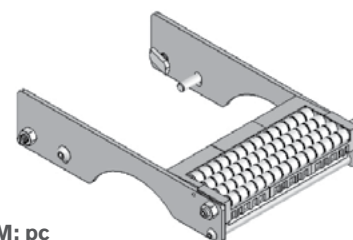

SEW gearmotors are products of SEW Eurodrive

FL Suspended End Drive without Motor (LEFT)

FLSD-A150-0L (with Torque Limiter)
 FLSD-A150SPT-0L (without Torque Limiter)

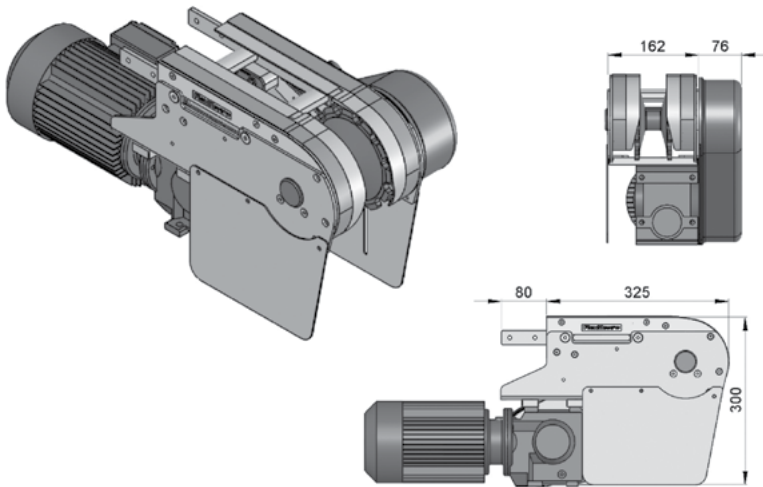

- Locates gearmotor below conveyor for compact applications.
- Includes torque limiter protecting chain and motor from overload.
- Chain pull capacity at 1250N for unit without torque limiter.
- Chain pull capacity at 840N for unit with torque limiter.

FL Suspended End Drive without Motor (RIGHT)

FLSD-A150-0R (with Torque Limiter)
 FLSD-A150SPT-0R (without Torque Limiter)

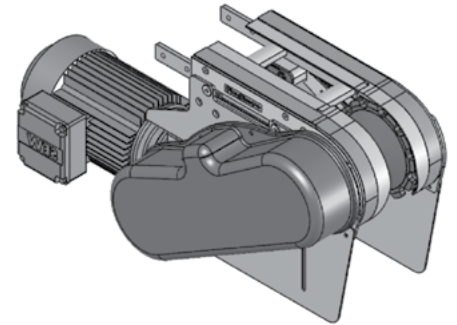

Max Traction Force:
1250N (without limiter)
800N (with limiter)

UOM: pc
 Chain required 2-way: 0.8 meter
 Slide rail required 2-way: 0.5 meter

FL Combined Suspended Drive & Idler (LEFT)

FLCDI-SD-A150-0L

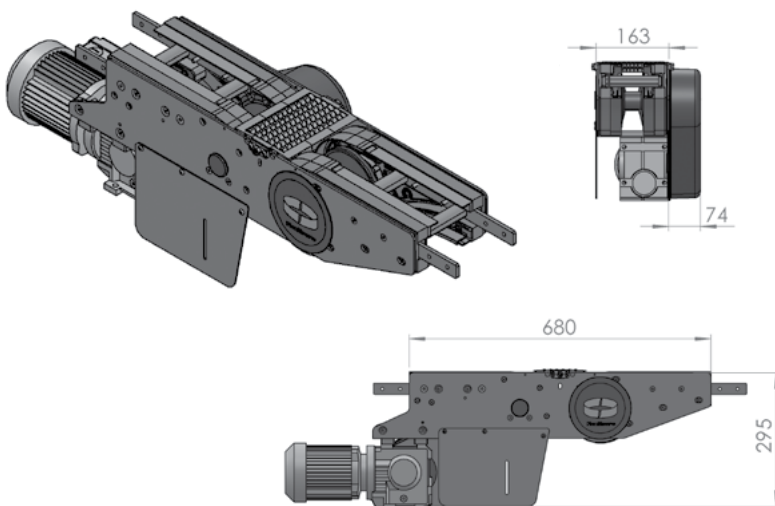

FL Combined Suspended Drive & Idler (RIGHT)

FLCDI-SD-A150-0R

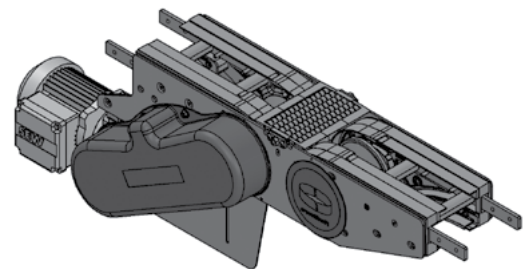

Max Traction Force: 800N
 The Combine Suspended End Drive Unit is with torque limiter.

UOM: pc
 Chain required 2-way: 1.6 meter
 Slide rail required 2-way: 1.0 meter

FL Combined Direct Drive & Idler (LEFT)

FLCDI-DD-A150-0L

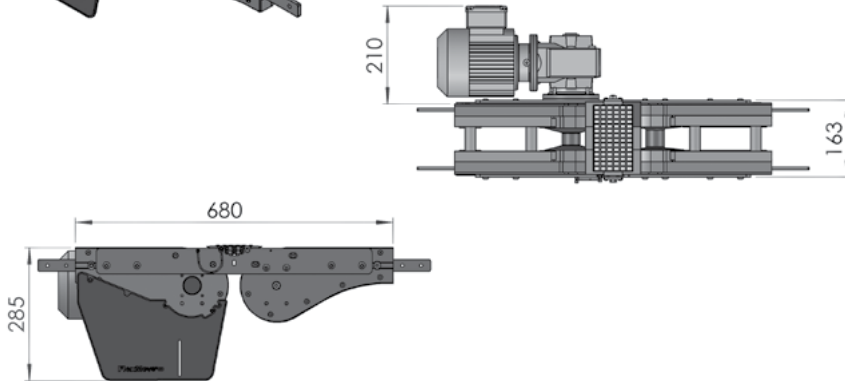
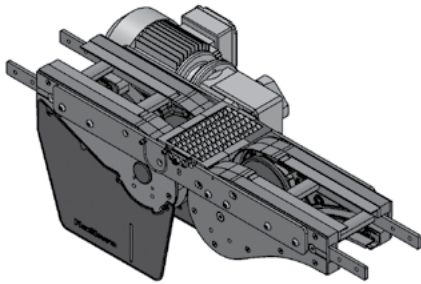

FL Combined Direct Drive & Idler (RIGHT)

FLCDI-DD-A150-0R

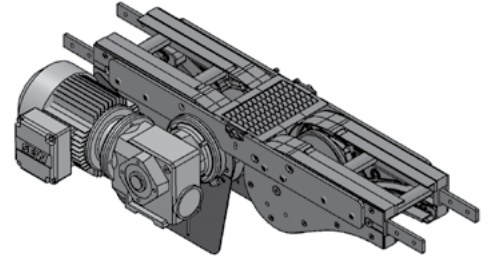

Max Traction Force: 1250N

The Combine Direct End Drive Unit is without torque limiter.

UOM: pc

Chain required 2-way: 1.6 meter
Slide rail required 2-way: 1.0 meter

FL Weighted Take-up Module

FL-WTU-700



- Provides automatic chain stretch take-up
- Reduces noise caused from catenary tail
- Must be used with GP Drive End, sold separately
- Used on conveyors over 12 M long

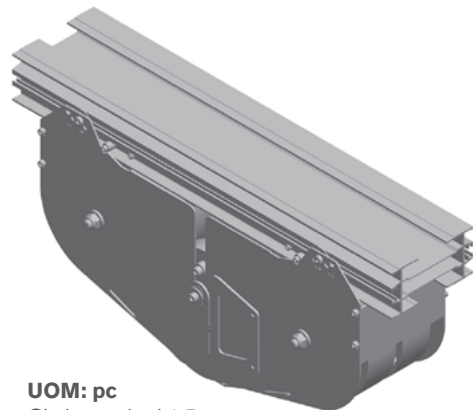
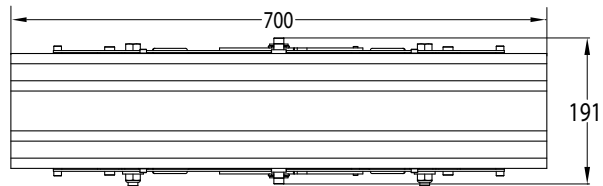

UOM: pc

Chain required 1.5 meter
Slide rail required 3.5 meter

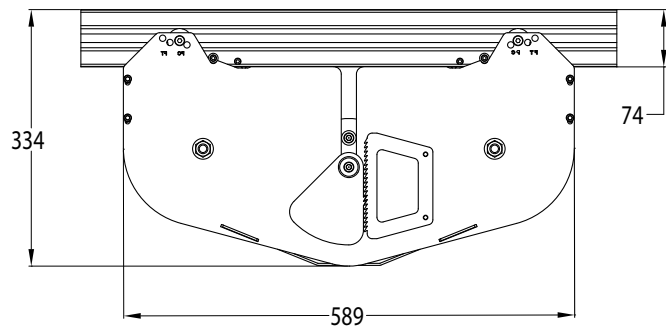

SEW gearmotors are products of SEW Eurodrive

FL Weighted Take-up Tail Module

FL-WTU-150

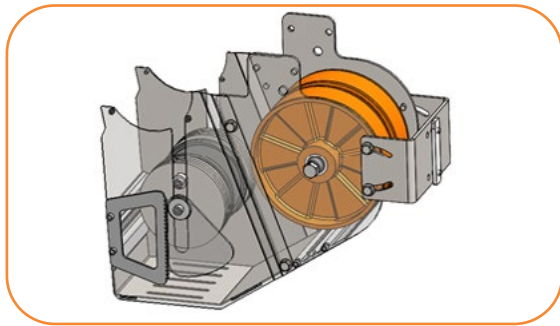

- Provides controlled chain take-up for improved conveyor performance
- Compact design fits in similar space as standard direct drive modules
- Smooths conveyor chain movement by helping to eliminate micro-surfing
- Suggested for conveyors over 12.2 M (40 ft) in length
- Capable of inclined and declined arrangement up to 30 degrees
- Improves operator safety by enclosing chain catenar
- Attaches to direct end drive tail
- Compatible with power transfer and driven bridge

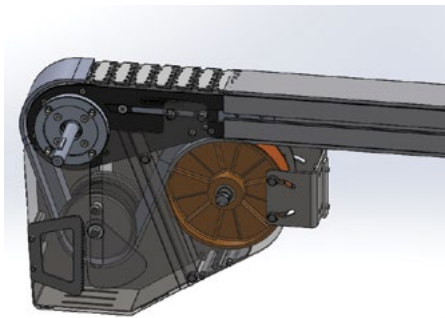

UOM: pc
 Chain required 1.5 meter
 Slide rail required 2.1 meter

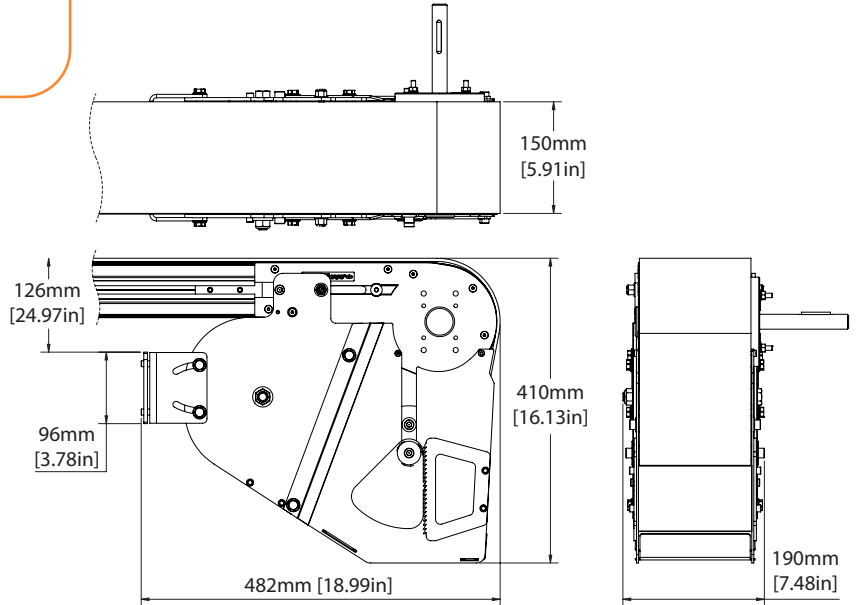

FL Top Running Drive Module

FLTRD-203

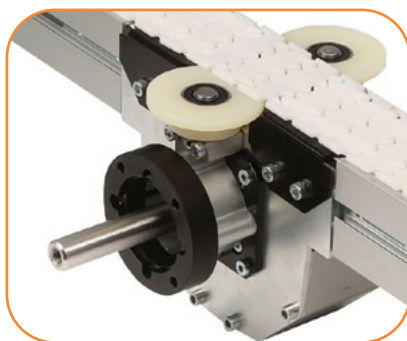

- For top running chain only
- 9M long conveyor length maximum
- 32 Kg load maximum
- Compatible with 3/4 inch shaft gearmotors only

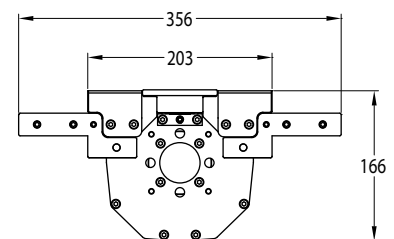
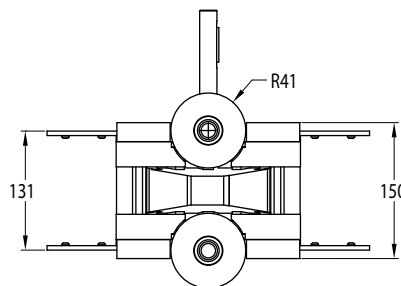
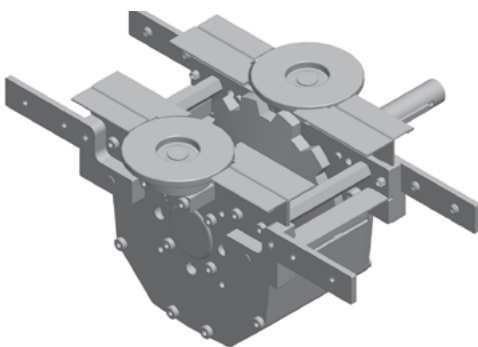

UOM: pc
 Chain required 0.2 meter

FL Idler End-150

FLIE-A150

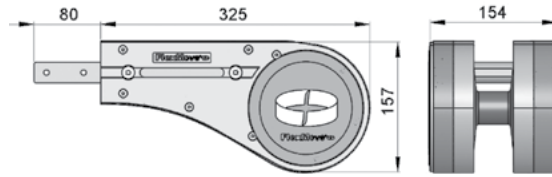
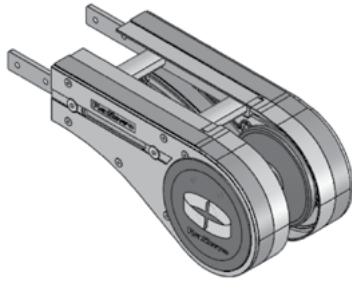

UOM: pc

Chain required 2-way: 0.8 meter
Slide rail required 2-way: 0.5 meter

FL Idler End with Power Transfer (LEFT)

FLIE-A150PT-L

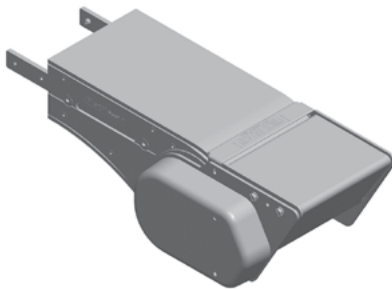

Minimum product length for inline transfer = 100 mm
Transfer extends past conveyor only 27 mm

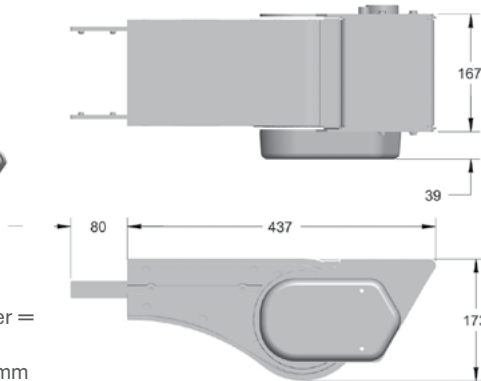

FL Idler End with Power Transfer (RIGHT)

FLIE-A150PT-R

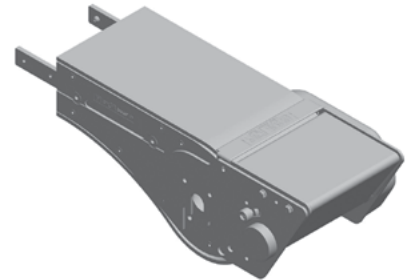

UOM: pc

Chain required 2-way: 0.8 meter
Slide rail required 2-way: 0.5 meter

FL Idler End Driven Transfer Bridge (LEFT)

FLIE-A150DB-A-L

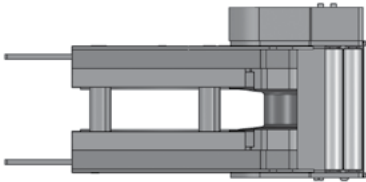

Minimum product length for inline transfer = 100 mm
Transfer extends past conveyor only 27 mm

UOM: pc

Chain required 2-way: 0.8 meter
Slide rail required 2-way: 0.5 meter

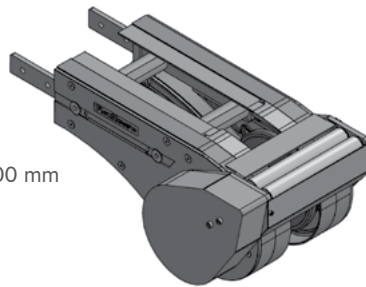

FL Direct Drive Driven Transfer Bridge (RIGHT)

FLIE-A150DB-A-R

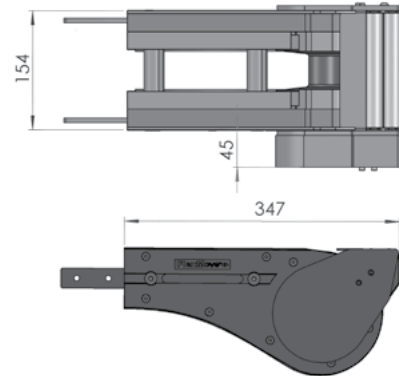

FL Idler End Free Transfer Bridge

FLTB-A150

Transfer bridge c/w roller for FLIE-A150,
FLDD-A150-XDY and FLDD-A150GP-XDY

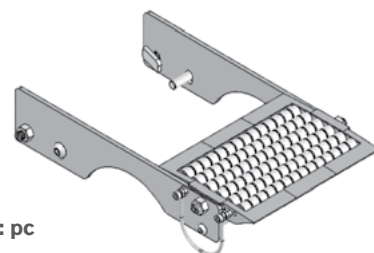
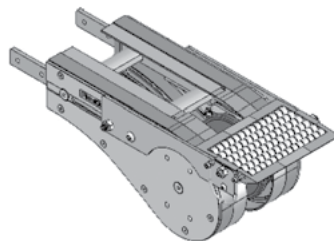
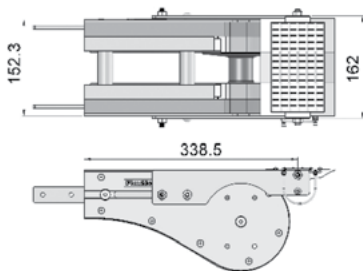

UOM: pc

FL Wheel Bend 180°

FLWB-180R210A

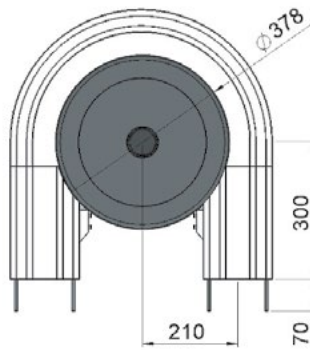
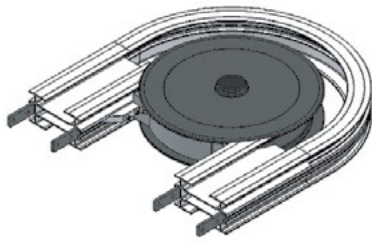

UOM: pc

Chain required 2-way: 2.5 meter
Slide rail required 2-way: 2.8 meter

FL Wheel Bend 90°

FLWB-90R210A

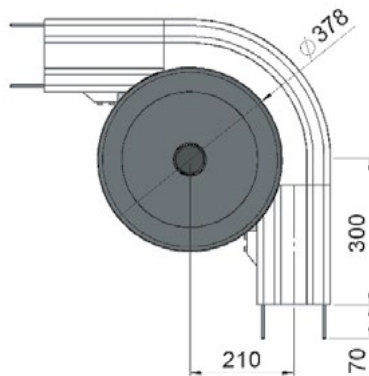
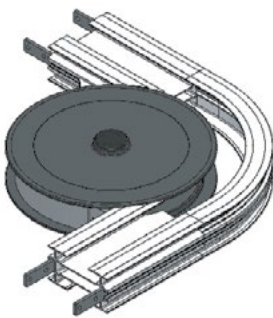

UOM: pc

Chain required 2-way: 1.9 meter
Slide rail required 2-way: 2.2 meter

FL Wheel Bend 60°

FLWB-60R210A

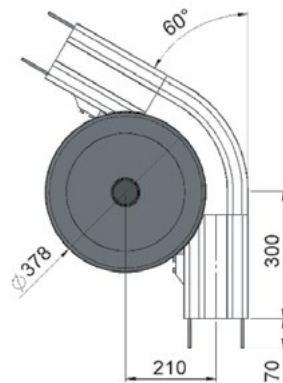
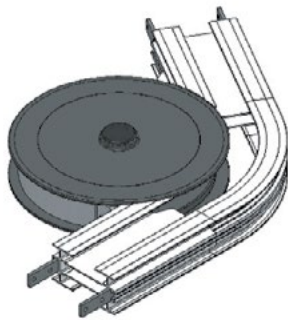

UOM: pc

Chain required 2-way: 1.6 meter
Slide rail required 2-way: 2.0 meter

FL Wheel Bend 45°

FLWB-45R210A

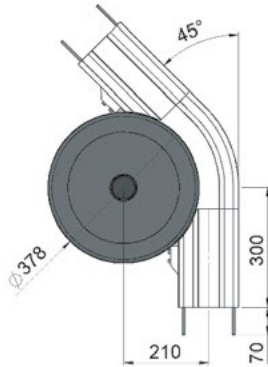
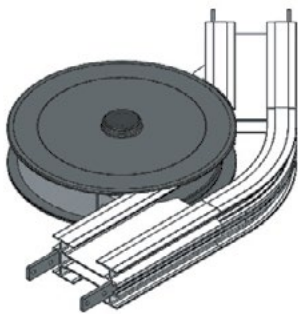

UOM: pc

Chain required 2-way: 1.5 meter
Slide rail required 2-way: 1.8 meter

FL Wheel Bend 30°

FLWB-30R210A

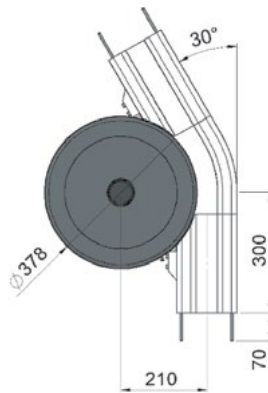
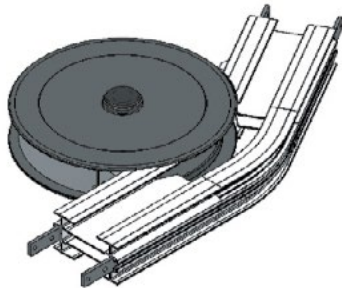

UOM: pc

Chain required 2-way: 1.4 meter
Slide rail required 2-way: 1.7 meter

FL Wheel Bend 5° - 180°

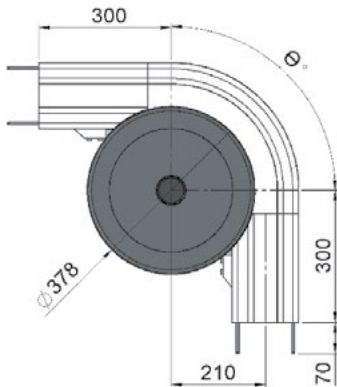

Example for FL Wheel Bend Ordering

- Wheel bend, $\varnothing \pm 1^\circ$
- FLWB- \varnothing° R210A

If an angle of 65° is needed for wheel bend, the ordering part number is

FLWB-65R210A

The outer bend is assembled using connecting strip (FACS-25x140A). Angle of \varnothing° must be indicated when ordering.

FL Horizontal Plain Bend 15°

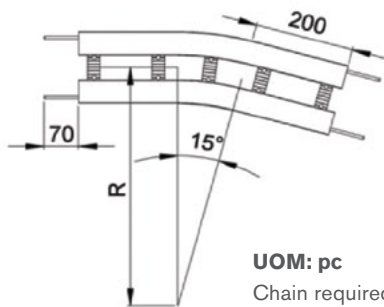

Horizontal plain bend, 15° ± 1°

- R = 500 ± 10 mm **FLHB-15R500**
- R = 700 ± 10 mm **FLHB-15R700**
- R = 1000 ± 10 mm **FLHB-15R1000**

UOM: pc

Chain required 2-way (300, 500, 700, 1000): 1, 1.1, 1.2, 1.3 meter
 Slide rail required 2-way (300, 500, 700, 1000): 1.9, 2.1, 2.3, 2.6 meter

FL Horizontal Plain Bend 30°

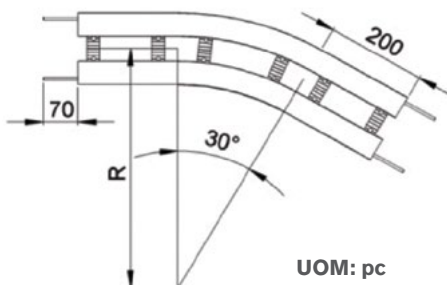

Horizontal plain bend, 30° ± 1°

- R = 500 ± 10 mm **FLHB-30R500**
- R = 700 ± 10 mm **FLHB-30R700**
- R = 1000 ± 10 mm **FLHB-30R1000**

UOM: pc

Chain required 2-way (300, 500, 700, 1000): 1.1, 1.3, 1.5, 1.8 meter
 Slide rail required 2-way (300, 500, 700, 1000): 2.2, 2.6, 3.1, 3.7 meter

FL Horizontal Plain Bend 45°

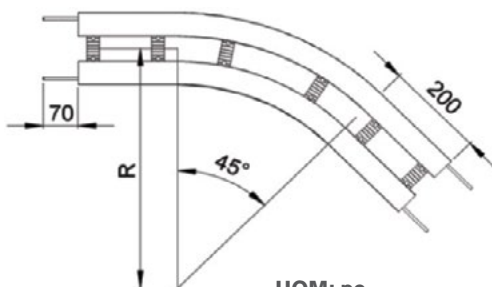
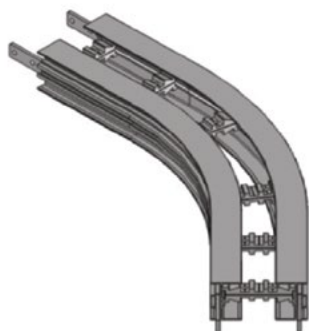

Horizontal plain bend, 45° ± 1°

- R = 500 ± 10 mm **FLHB-45R500**
- R = 700 ± 10 mm **FLHB-45R700**
- R = 1000 ± 10 mm **FLHB-45R1000**

UOM: pc

Chain required 2-way (300, 500, 700, 1000): 1.3, 1.6, 1.9, 2.4 meter
 Slide rail required 2-way (300, 500, 700, 1000): 2.5, 3.2, 3.8, 4.7 meter

FL Horizontal Plain Bend 60°

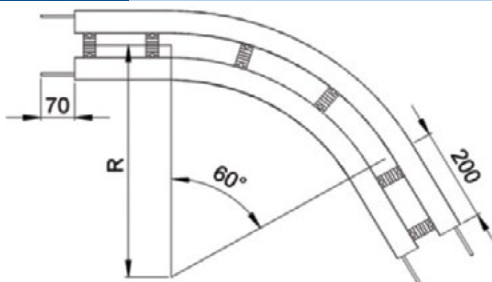

Horizontal plain bend, 60° ± 1°

- R = 500 ± 10 mm **FLHB-60R500**
- R = 700 ± 10 mm **FLHB-60R700**
- R = 1000 ± 10 mm **FLHB-60R1000**

UOM: pc

Chain required 2-way (300, 500, 700, 1000): 1.4, 1.8, 2.3, 2.9 meter
 Slide rail required 2-way (300, 500, 700, 1000): 2.9, 3.7, 4.5, 5.8 meter

FL Horizontal Plain Bend 90°

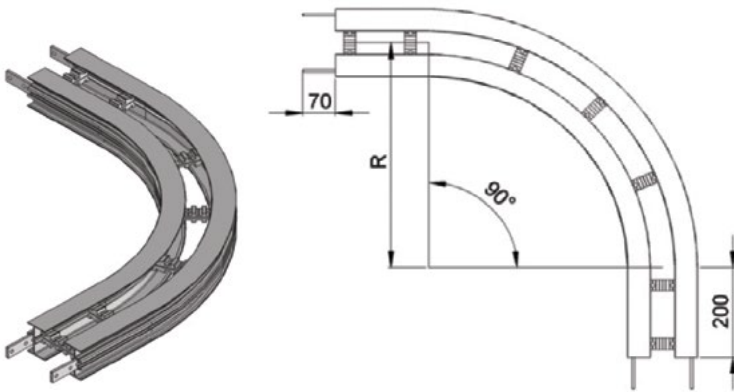

Horizontal plain bend, 90° ± 1°

R = 500 ± 10 mm	FLHB-90R500
R = 700 ± 10 mm	FLHB-90R700
R = 1000 ± 10 mm	FLHB-90R1000

UOM: pc

Chain required 2-way (300, 500, 700, 1000):

1.7, 2.4, 3.0, 3.9 meter

Slide rail required 2-way (300, 500, 700, 1000):

3.5, 4.7, 6.0, 7.9 meter

FL Horizontal Plain Bend 180°

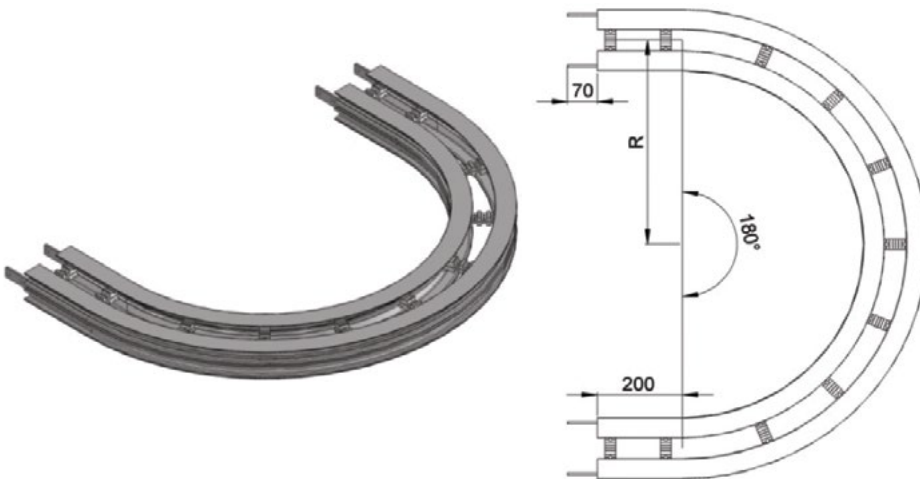

Horizontal plain bend, 180° ± 1°

R = 500 ± 10 mm	FLHB-180R500
R = 700 ± 10 mm	FLHB-180R700
R = 1000 ± 10 mm	FLHB-180R1000

UOM: pc

Chain required 2-way (500, 700, 1000) : 4.0, 5.2, 7.1 meter

Slide rail required 2-way (500, 700, 1000): 7.9, 1.1, 14.2 meter

FL Horizontal Plain Bend 5° - 180°

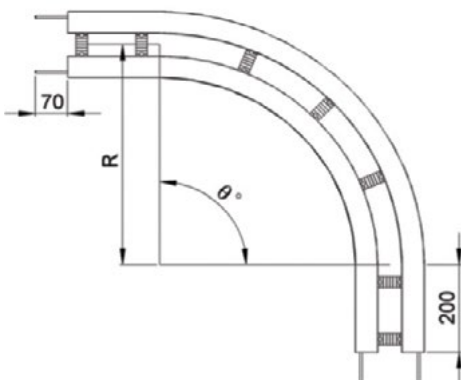

Example for FL Horizontal Plain Bend Ordering

Horizontal plain bend, θ° ± 1°

R = 500 ± 10 mm	FLHB- θ°R500
R = 700 ± 10 mm	FLHB- θ°R700
R = 1000 ± 10 mm	FLHB- θ°R1000

If an angle of 120° is needed for radius R500 horizontal plain bend, the ordering part number is

FLHB-120R500

UOM: pc

Chain required 2-way (500, 700, 1000) : meter (variable to angle)

Slide rail required 2-way (500, 700, 1000): meter (variable to angle)

FL Vertical Bend 5°

FLVB-5R500

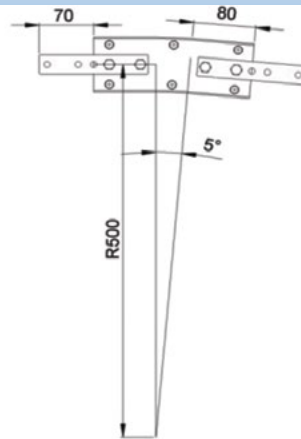
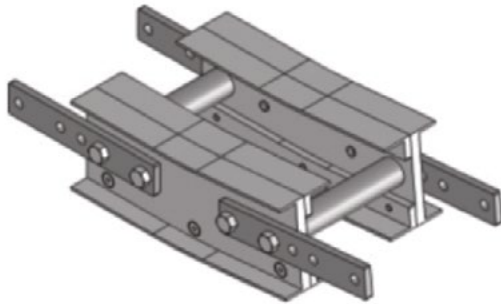

UOM: pc

Chain required 2-way: 0.4 meter
Slide rail required 2-way: 0.8 meter

FL Vertical Bend 10°

FLVB-10R500

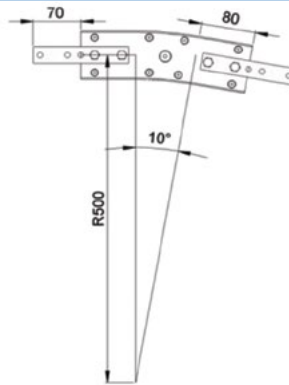
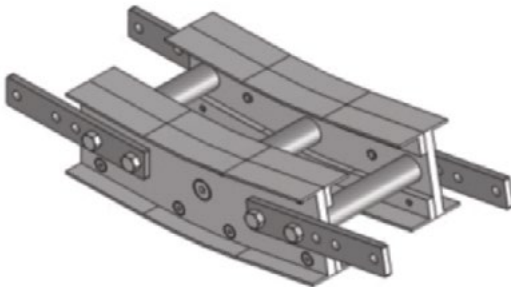

UOM: pc

Chain required 2-way: 0.5 meter
Slide rail required 2-way: 1.0 meter

FL Vertical Bend 15°

FLVB-15R500

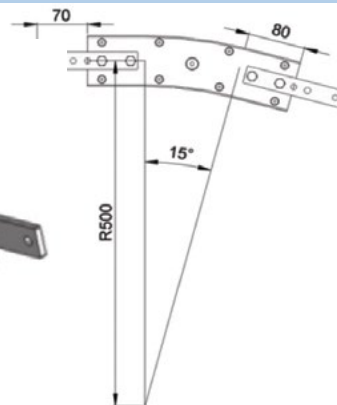
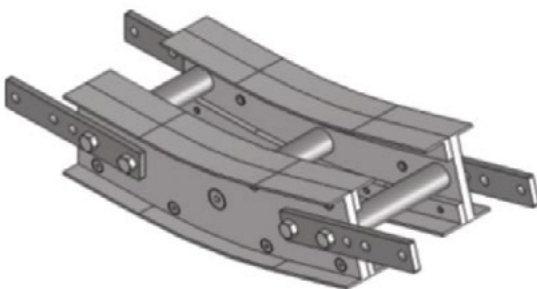

UOM: pc

Chain required 2-way: 0.6 meter
Slide rail required 2-way: 1.2 meter

FL Vertical Bend 20°

FLVB-20R500

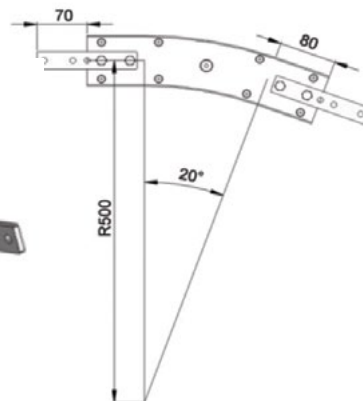
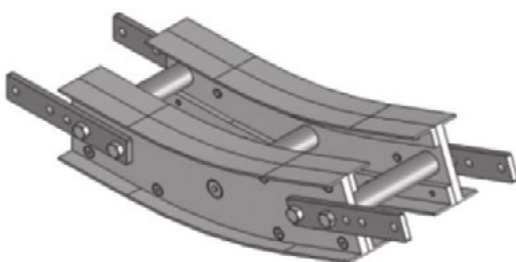

UOM: pc

Chain required 2-way: 0.7 meter
Slide rail required 2-way: 1.3 meter

FL Vertical Bend 30°

FLVB-30R500

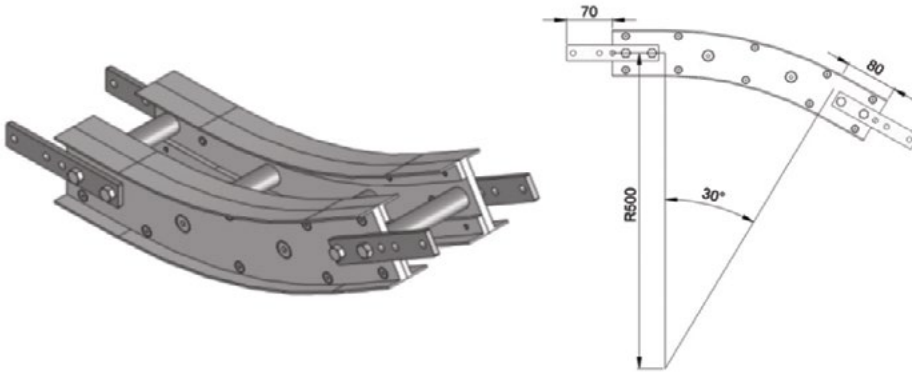

UOM: pc

Chain required 2-way: 0.8 meter
Slide rail required 2-way: 1.7 meter

FL Vertical Bend 45°

FLVB-45R500

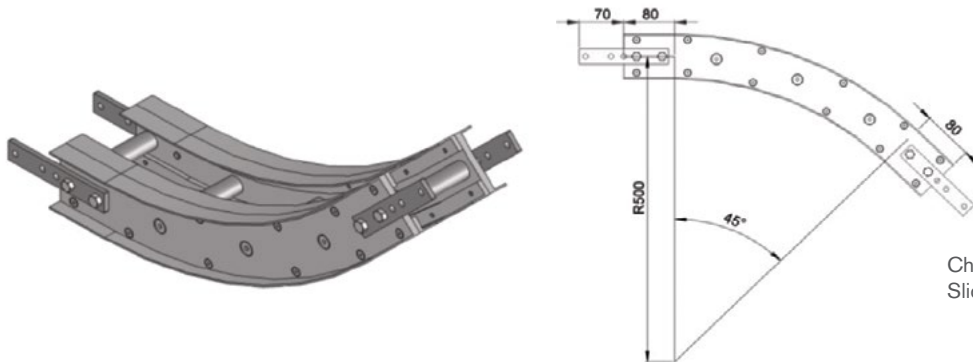

Chain required 2-way: 1.1 meter
Slide rail required 2-way: 2.2 meter

FL Vertical Bend 5°-90°

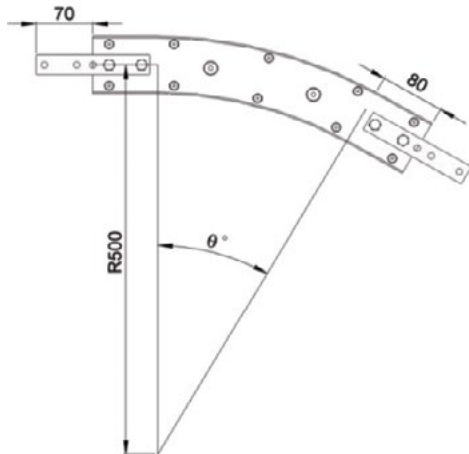

Example for FL Vertical Bend Ordering

- Vertical bend, $\theta^\circ \pm 1^\circ$
- FLVB- θ° R500

If an angle of 65° is needed for vertical bend, the ordering part number is

FLVB-65R500

The outer bend is assembled using connecting strip (FACS-25x140A). Angle of "θ" must be indicated when ordering.

FL S In-Line Transfer Module

FLST-150

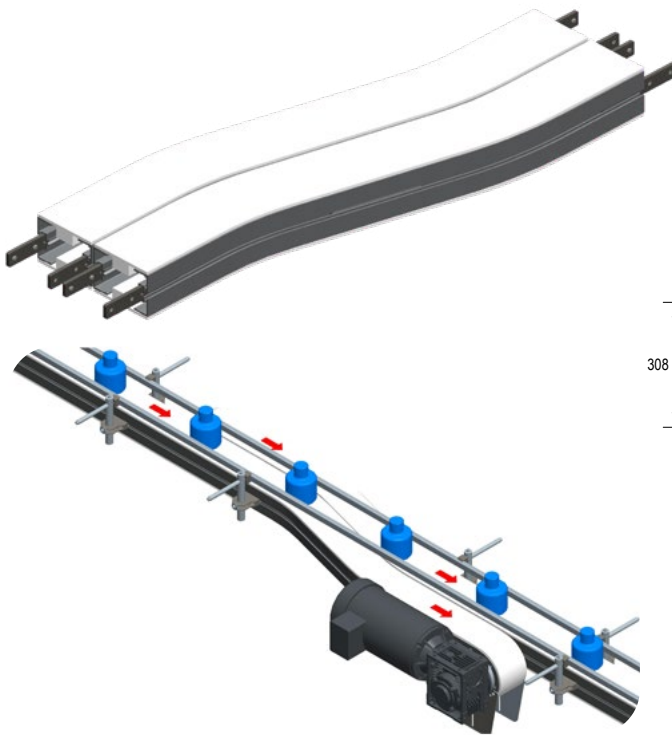

- S In-Line Modules provide a standard, compact way to side transfer product from conveyor to conveyor.
- Straight guiding is placed across the transfer module for smooth In-Line product flow
- Conveyors are mounted together to provide a smooth transfer even for small products
- S In-Line transfers are compact in the width dimension

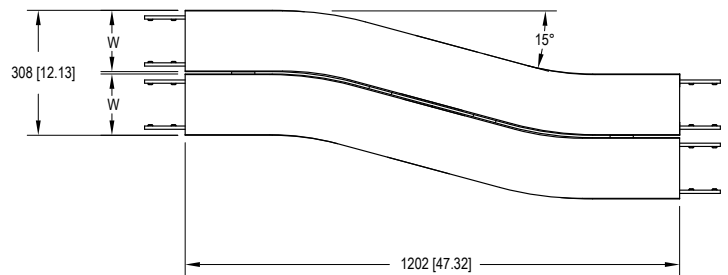

FL X In-Line Transfer Module

FLXT-150



- X In-Line Modules provide a standard, compact way to side transfer product from conveyor to conveyor.
- Straight guiding is placed across the transfer module for smooth In-Line product flow
- Conveyors are mounted together to provide a smooth transfer even for small products
- X In-Line transfers are compact in the length direction

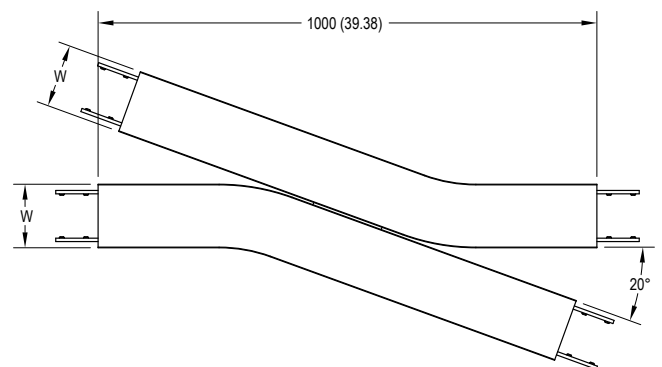

Variety of chain type suitable for wide range of applications either horizontal or vertical product transportation. The maximum product width to be conveyed can be referred to guide rail assembly pages.

FU180 Series Characteristic

Beam Width: 179 mm

Product Width: Refer to Guide Rail Assembly

Accessories Needed

Slide Rail Required: FASR-25, FASR-25U, FASR-25X

Slide Rail Color: White or Natural Color

Slide Rail Material: HDPE, UHMW OR SPECIAL PE

Slide Rail Rivet & Screw: FASLR-4X6 or FASLS-M5

Connecting strip is used to connect two beams.

Connecting Strip: FACS-25x140A

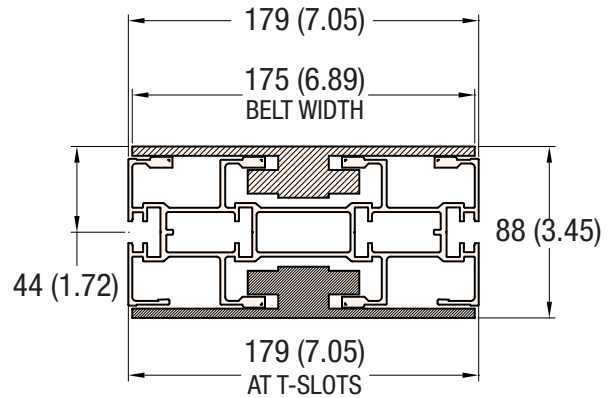

180 MM WIDTH

Conveyor Beam FUCB-3

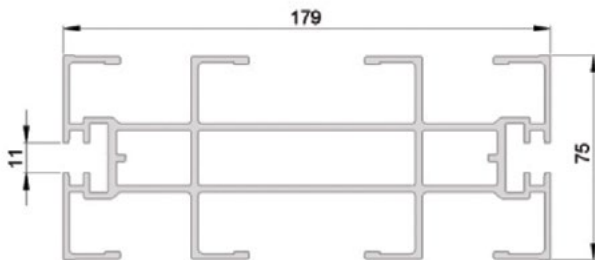

UOM: 3 Meter / Length

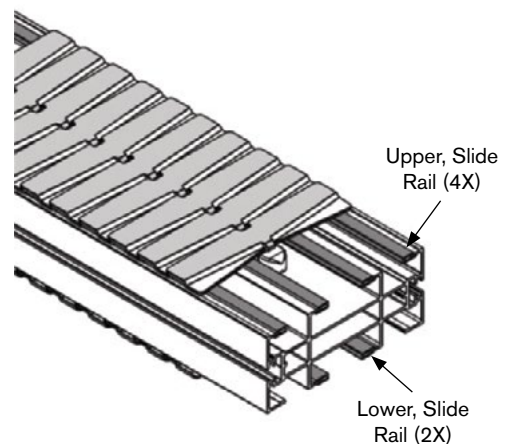

Chain Connecting Module FUCC-300

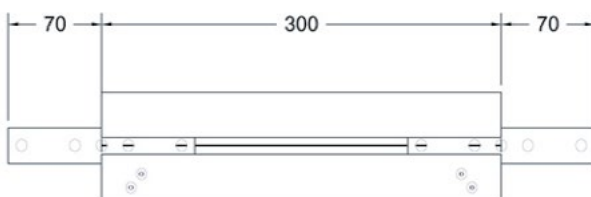

UOM: 3 Meter / Length

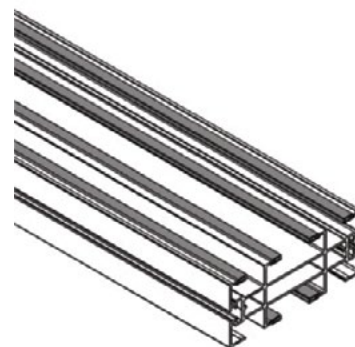

Chain Common Data

Packaging: 5 m per box

Pitch: 33.5 mm

Width: 175 mm

Tensile Strength at 20°C: 6000N

Color: White

Material:

Chain: White Acetal / POM

Pivot: Polyamide

Pivot Pin: Stainless Steel

Insert (Wedge & Friction): TPE Grey

Plain Chain FUPC-5

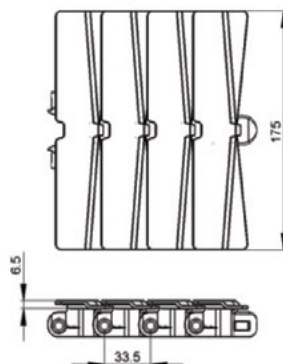
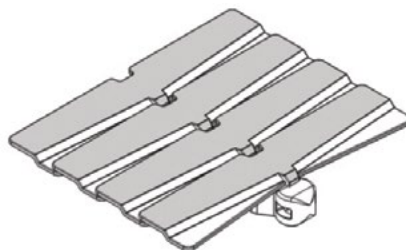

UOM: 5 Meter / box

Application: Suitable for horizontal and slope < 5° transport of products with accumulation.

Roller Plain Chain FUPC-5R

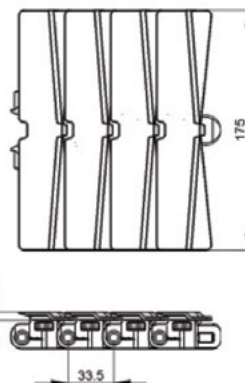
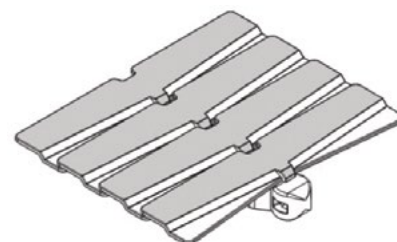

UOM: 5 Meter / box

Application: Suitable for horizontal and slope < 5° transport of products with accumulation.

Note: Friction Reducing Roller Chain Recommended for high speed or high load plain bends

Friction Top Chain FUFT-B-5

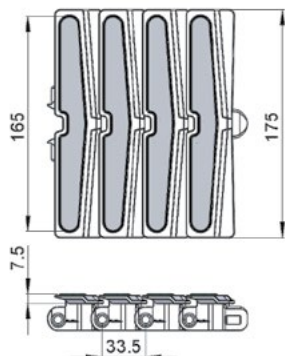
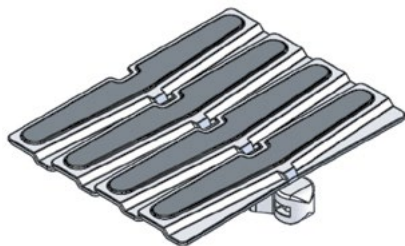

UOM: 5 Meter / box

Application: Suitable for horizontal and slope ≤ 30° transport of products without accumulation.

Roller Friction Top Chain FUFT-B-5R

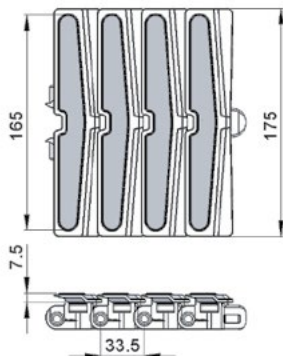
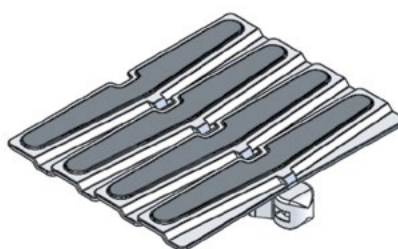

UOM: 5 Meter / box

Application: Suitable for horizontal and slope ≤ 30° transport of products without accumulation.

Note: Friction Reducing Roller Chain Recommended for high speed or high load plain bends

Twist Chain FUPC-5M

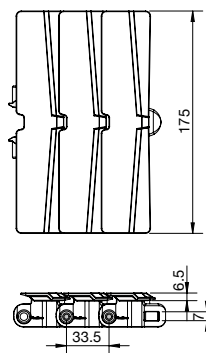
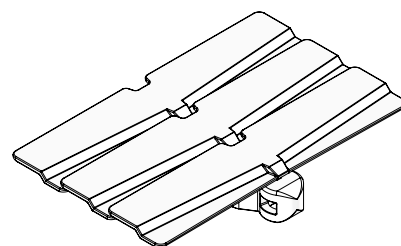

UOM: 5 Meter / box

Application: Suitable twist conveyor beam; horizontal and slope < 5° transport of products with accumulation.

FU Direct End Drive with Motor (LEFT)
FUDD-A180-XDY (See Chart)

FU Direct End Drive with Motor (RIGHT)
FUDD-A180-XDY (See Chart)

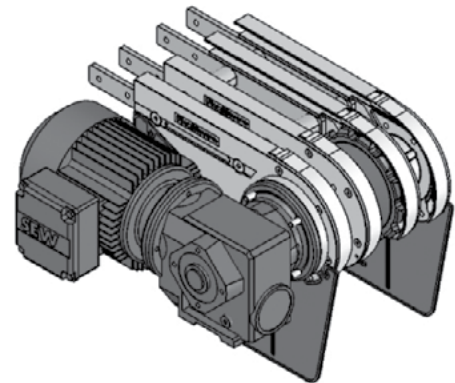
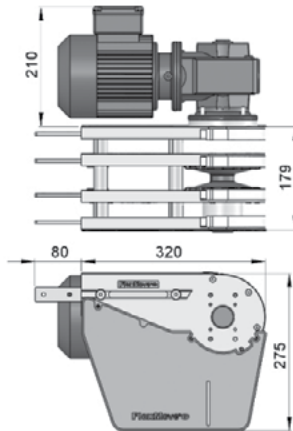
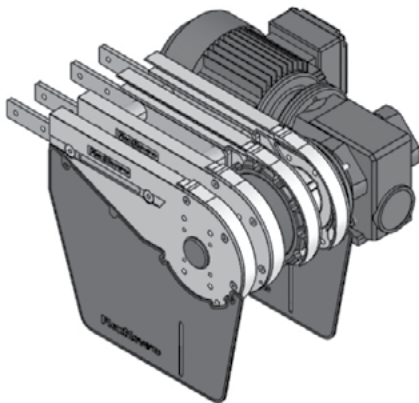

Part Number	Shaft Selection	Direction	Aux Shaft Selection
FUDD-A180	X	D	Y
	0 = 20 mm	L = Left	Blank = No Aux Shaft
	E = 3/4 in*	R = Right	A = 20 mm Aux Shaft
	A = 20 mm Aux Only		

Max Traction Force: 1250N
The Direct End Drive Unit is without torque limiter.

UOM: pc
Chain required 2-way: 0.8 meter
Slide rail required 2-way: 1.0 meter

*3/4 inch shaft option available in North America only.

FU Direct End Drive unit without Motor GP (LEFT)
FUDD-A180GP-XDY (See Chart)

FU Direct End Drive unit without Motor GP (RIGHT)
FUDD-A180GP-XDY (See Chart)

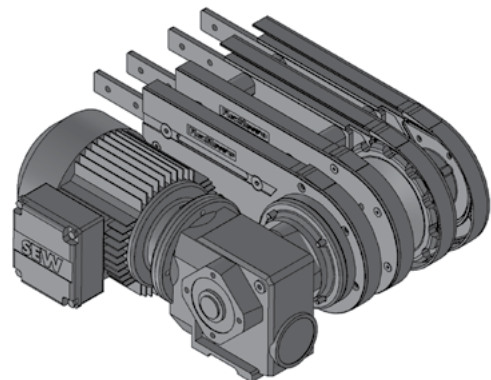
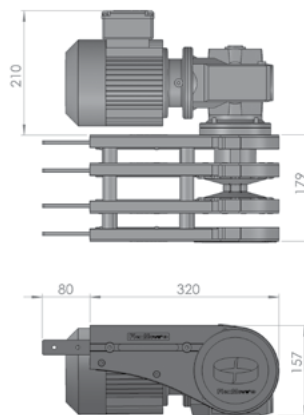
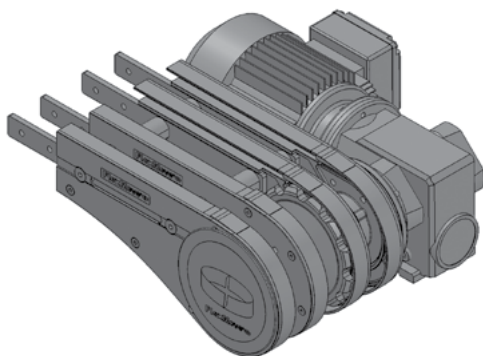

Requires the use of connecting or weighted take-up module for chain maintenance.

Part Number	Shaft Selection	Direction	Aux Shaft Selection
FUDD-A180GP	X	D	Y
	0 = 20 mm	L = Left	Blank = No Aux Shaft
	E = 3/4 in*	R = Right	A = 20 mm Aux Shaft
	A = 20 mm Aux Only		

Max Traction Force: 1250N
The Direct End Drive Unit GP is without torque limiter.

UOM: pc
Chain required 2-way: 0.8 meter
Slide rail required 2-way: 1.0 meter

*3/4 inch shaft option available in North America only.

SEW gearmotors are products of SEW Eurodrive

FU Direct with Power Transfer Motor (LEFT)

FUDD-A180PT-XD (See Chart)

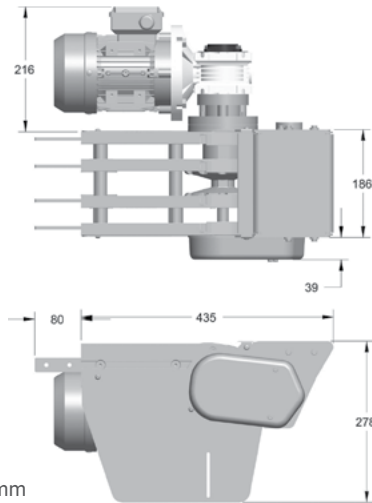
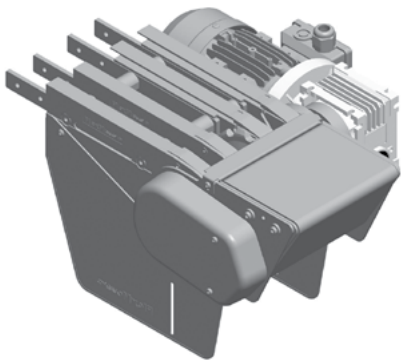

FU Direct with Power Transfer Motor (RIGHT)

FUDD-A180PT-XD (See Chart)

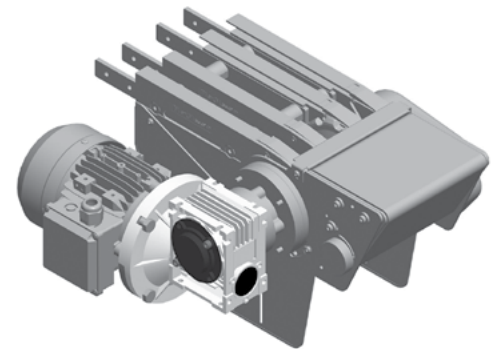

Minimum product length for inline transfer = 100 mm

Maximum speed is 30 m/min (100 ft/min)

Only one power transfer needed on either infeed or discharge trail required for end to end transfer. Provides extended transfer nose for interfacing with large rollers.

Part Number		Shaft Selection	Direction
FUDD-A180PT	-	X	D
		0 = 20 mm	L = Left
		E = 3/4 in*	R = Right

*3/4 inch shaft option available in North America only.

Max Traction Force: 1250N

The Direct End Drive Unit is without torque limiter.

UOM: pc

Chain required 2-way: 0.8 meter

Slide rail required 2-way: 1.0 meter

FU GP Direct with Power Transfer Motor (LEFT)

FUDD-A180GPPT-XD (See Chart)

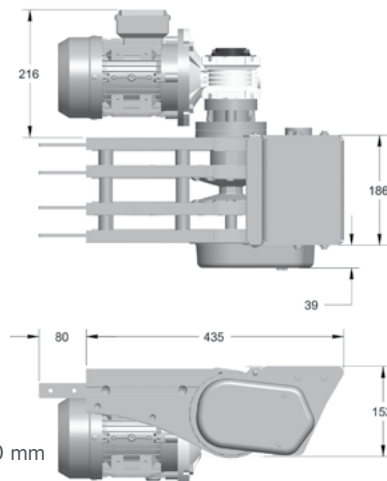
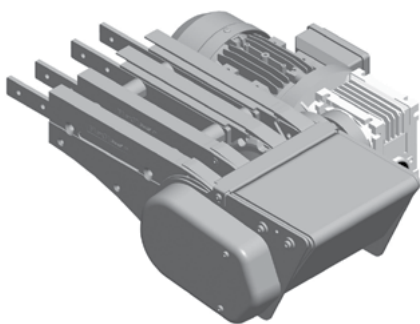

FU GP Direct with Power Transfer Motor (RIGHT)

FUDD-A180GPPT-XD (See Chart)

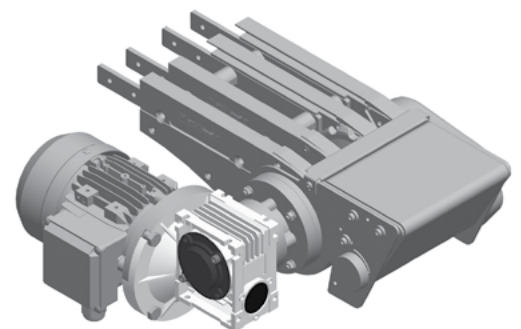

Minimum product length for inline transfer = 100 mm

Maximum speed is 30 m/min (100 ft/min)

Only one power transfer needed on either infeed or discharge trail required for end to end transfer. Provides extended transfer nose for interfacing with large rollers.

Requires the use of connecting or weighted take-up module for chain maintenance.

Part Number		Shaft Selection	Direction
FUDD-A180GPPT	-	X	D
		0 = 20 mm	L = Left
		E = 3/4 in*	R = Right

*3/4 inch shaft option available in North America only.

Max Traction Force: 1250N

The Direct End Drive Unit GP is without torque limiter.

UOM: pc

Chain required 2-way: 0.8 meter

Slide rail required 2-way: 1.0 meter

SEW gearmotors are products of SEW Eurodrive

FU Direct Drive Driven Transfer Bridge (LEFT)

FUDD-A180DB-A-0L

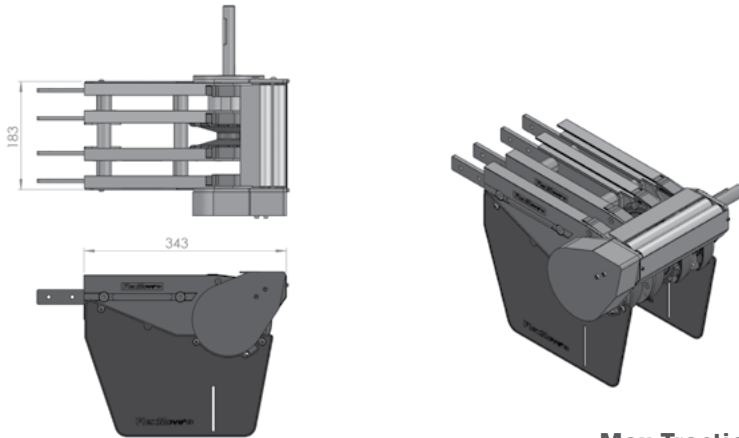

UOM: pc

20 mm Shaft only.

Minimum product length for inline transfer = 100 mm

Transfer extends past conveyor only 27 mm

FU Direct Drive Driven Transfer Bridge (RIGHT)

FUDD-A180DB-A-0R

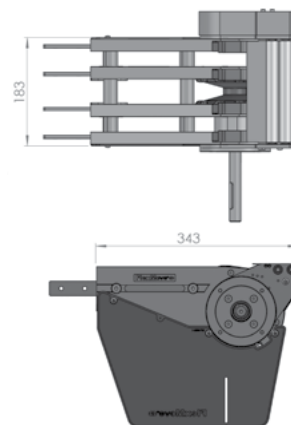

Max Traction Force: 1250N

The Direct End Drive Unit is without torque limiter.

UOM: pc

Chain required 2-way: 0.8 meter

Slide rail required 2-way: 0 meter

FU Direct Drive Free Roller Transfer Bridge (LEFT/ RIGHT)

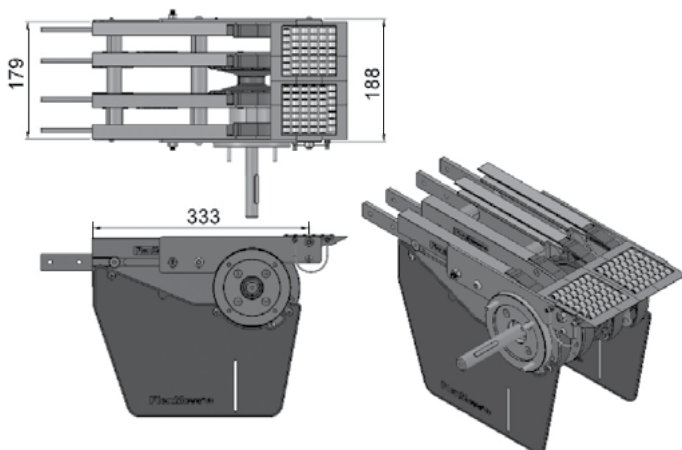

FUTB-A180

Transfer bridge c/w roller for FUIE-A180, FUDD-A180-XDY and FUDD-A180GP-XDY

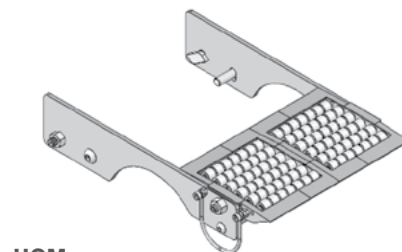

UOM: pc

FU Direct Drive End Free Roller Bridge (LEFT/ RIGHT)

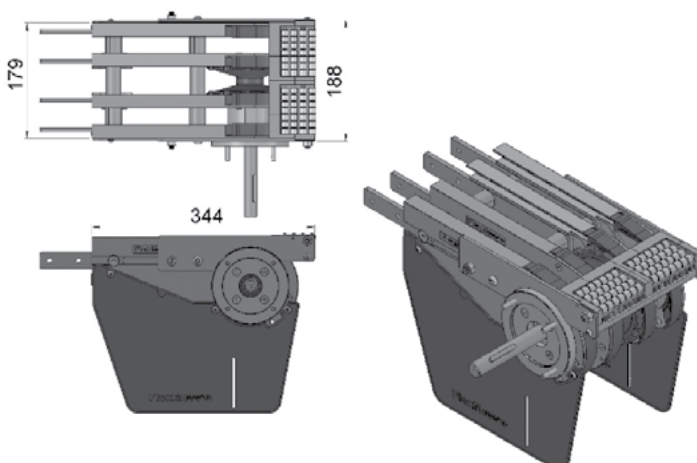

FUEB-A180

End transfer bridge c/w roller for FUIE-A180, FUDD-A180-XDY and FUDD-A180GP-XDY

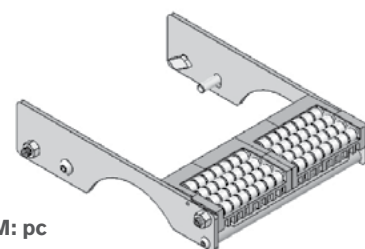

UOM: pc

FU Suspended Drive with Motor (LEFT)

FUSD-A180-0L (with Torque Limiter)
FUSD-A180SPT-0L (without Torque Limiter)

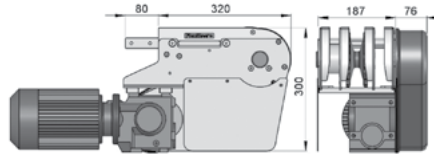
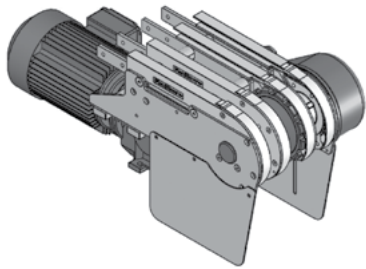

FU Suspended Drive with Motor (RIGHT)

FUSD-A180-0R (with Torque Limiter)
FUSD-A180SPT-0R (without Torque Limiter)

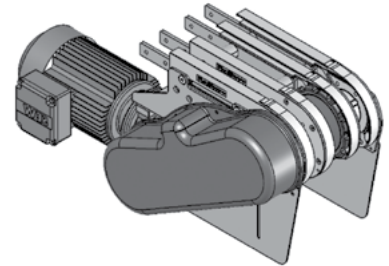

- Locates gearmotor below conveyor for compact applications.
- Includes torque limiter protecting chain and motor from overload.
- Chain pull capacity at 1250N for unit without torque limiter.
- Chain pull capacity at 840N for unit with torque limiter.

Max Traction Force: 1250N
1250N (without limiter)
840N (with limiter)

UOM: pc
Chain required 2-way: 0.8 meter
Slide rail required 2-way: 1.0 meter

FU Weighted Take-up Module

FU-WTU-700



- Provides automatic chain stretch take-up
- Reduces noise caused from catenary tail
- Must be used with GP Drive End, sold separately
- Used on conveyors over 12 M long

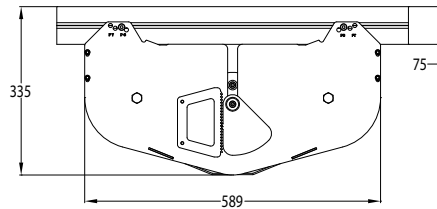

UOM: pc
Chain required 1.5 meter
Slide rail required 3.5 meter

FU Weighted Take-up Tail Module

FU-WTU-180

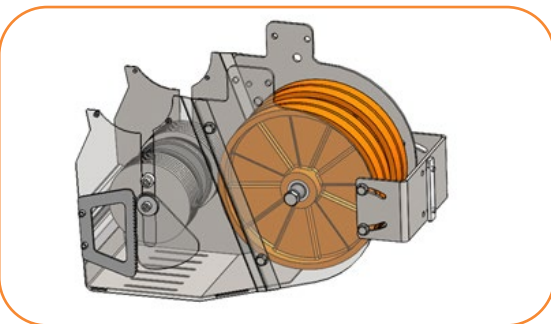

UOM: pc
Chain required 1.5 meter
Slide rail required 2.1 meter

- Provides controlled chain take-up for improved conveyor performance
- Compact design fits in similar space as standard direct drive modules
- Smooths conveyor chain movement by helping to eliminate micro-surfing
- Suggested for conveyors over 12.2 M (40 ft) in length
- Capable of inclined and declined arrangement up to 30 degrees
- Improves operator safety by enclosing chain catenary
- Attaches to direct end drive tail
- Compatible with power transfer and driven bridge

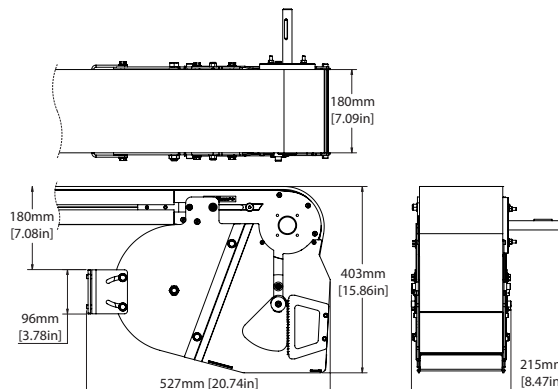

FU Idler End-180

FUIE-A180

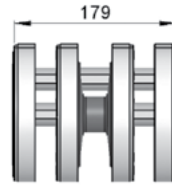
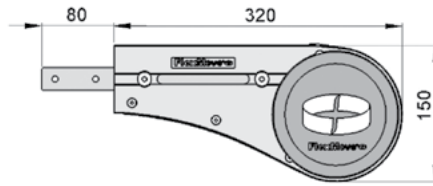
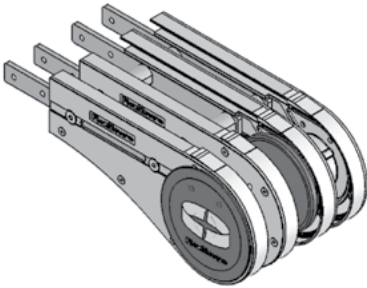

UOM: pc
Chain required 2-way: 0.8 meter
Slide rail required 2-way: 1.0 meter

FU Idler End with Power Transfer (LEFT)

FUIE-A180PT-L

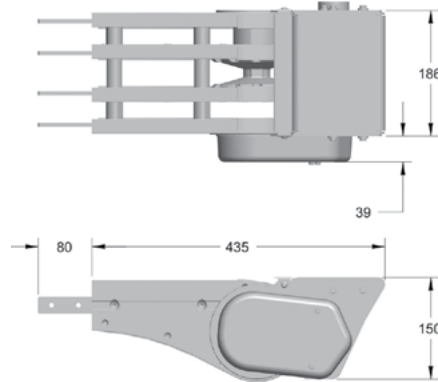
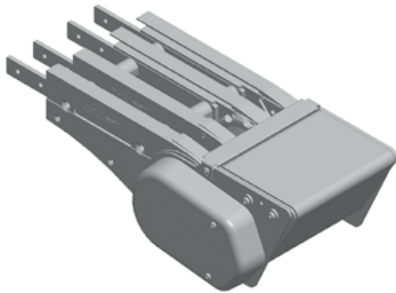

Minimum product length for inline transfer = 100 mm
Provides extended transfer nose for interfacing with large rollers.

FU Idler End with Power Transfer (RIGHT)

FUIE-A180PT-R

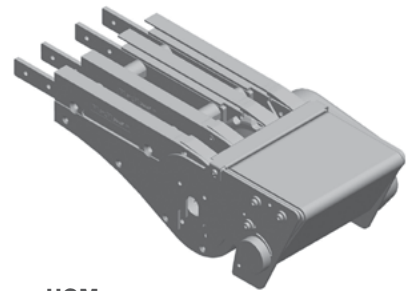

UOM: pc
Chain required 2-way: 0.8 meter
Slide rail required 2-way: 1.0 meter

FU Idler End Driven Transfer Bridge (LEFT)

FUIE-A180DB-A-L

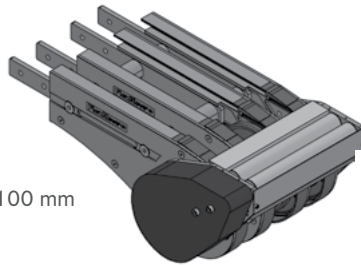
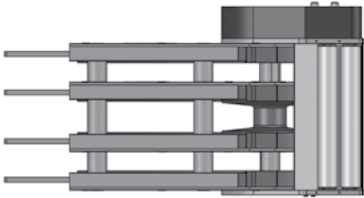

Minimum product length for inline transfer = 100 mm
Transfer extends past conveyor only 27 mm

UOM: pc
Chain required 2-way: 0.8 meter
Slide rail required 2-way: 1.0 meter

FU Idler End Driven Transfer Bridge (RIGHT)

FUIE-A180DB-A-R

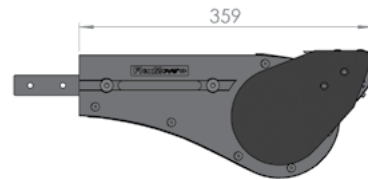
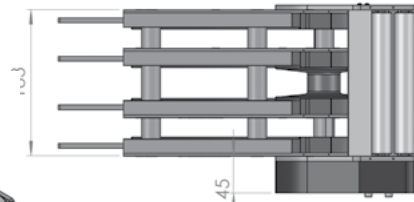

FU Idler Free Roller Transfer Bridge

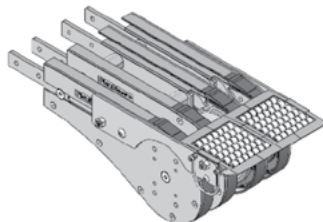
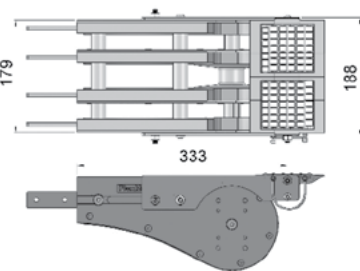

FUTB-A180

Transfer bridge c/w roller for FUIE-A180, FUDD-A180-XDY and FUDD-A180GP-XDY

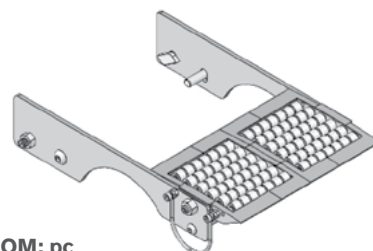

UOM: pc

FU Idler End Free Roller Bridge

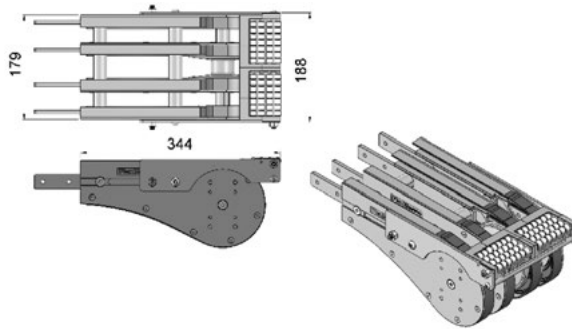

FUEB-A180

End transfer bridge c/w roller for FUIE-A180, FUDD-A180-XDY and FUDD-A180GP-XDY

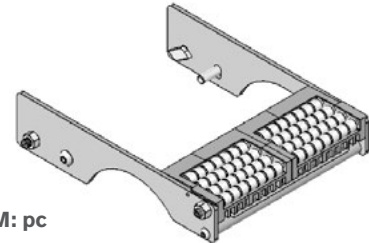

UOM: pc

FU Horizontal Plain Bend 30°

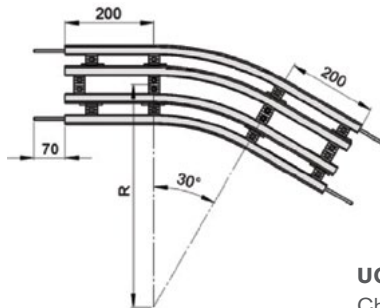

Horizontal plain bend, 30° ± 1°

- R = 500 ± 10 mm **FUHB-30R500**
- R = 700 ± 10 mm **FUHB-30R700**
- R = 1000 ± 10 mm **FUHB-30R1000**

UOM: pc

Chain required 2-way (500, 700, 1000): 1.3, 1.5, 1.8 meter
Slide rail required 2-way (500, 700, 1000): 4.0, 4.6, 5.5 meter

FU Horizontal Plain Bend 45°

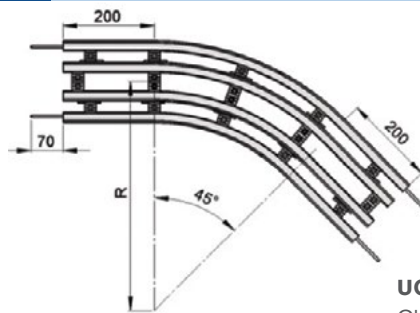

Horizontal plain bend, 45° ± 1°

- R = 500 ± 10 mm **FUHB-45R500**
- R = 700 ± 10 mm **FUHB-45R700**
- R = 1000 ± 10 mm **FUHB-45R1000**

UOM: pc

Chain required 2-way (500, 700, 1000): 1.6, 1.9, 2.4 meter
Slide rail required 2-way (500, 700, 1000): 4.8, 5.7, 7.1 meter

FU Horizontal Plain Bend 60°

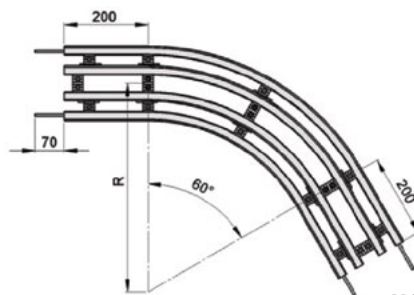

Horizontal plain bend, 60° ± 1°

- R = 500 ± 10 mm **FUHB-60R500**
- R = 700 ± 10 mm **FUHB-60R700**
- R = 1000 ± 10 mm **FUHB-60R1000**

UOM: pc

Chain required 2-way (500, 700, 1000): 1.8, 2.3, 2.9 meter
Slide rail required 2-way (500, 700, 1000): 5.5, 6.8, 8.7 meter

FU Horizontal Plain Bend 90°

FUVB-10R400

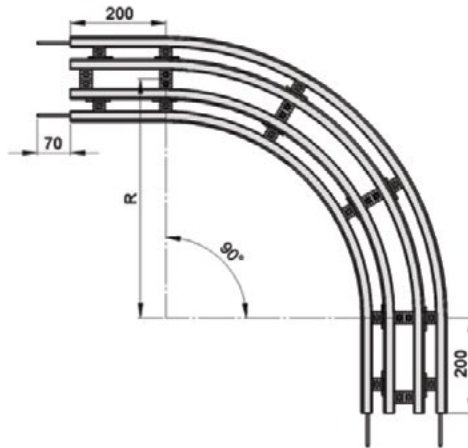
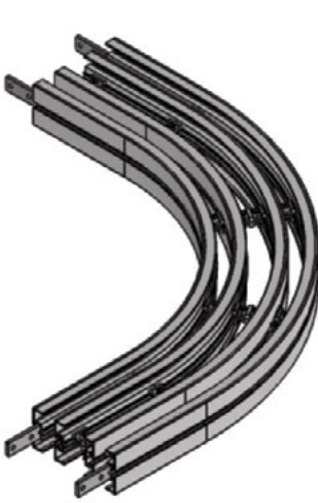

Horizontal plain bend, 90° ± 1°

- R = 500 ± 10 mm **FUHB-90R500**
- R = 700 ± 10 mm **FUHB-90R700**
- R = 1000 ± 10 mm **FUHB-90R1000**

UOM: pc

Chain required 2-way (500, 700, 1000): 2.4, 3.0, 3.9 meter
 Slide rail required 2-way (500, 700, 1000): 7.1, 9.0, 11.8 meter

FU Horizontal Plain Bend 5° - 180°

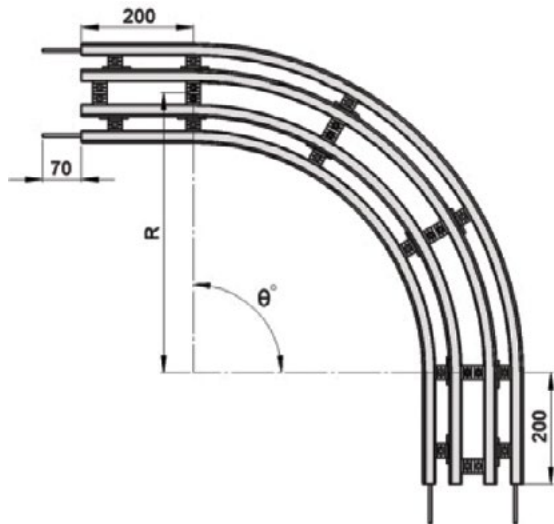

Example for FU Horizontal Plain Bend Ordering

Horizontal plain bend, θ° ± 1°

- R = 500 ± 10 mm **FUHB - θ°R500**
- R = 700 ± 10 mm **FUHB - θ°R700**
- R = 1000 ± 10 mm **FUHB - θ°R1000**

If an angle of 120° is needed for radius R500 horizontal plain bend, the ordering part number is

FUHB-120R500

UOM: pc

Chain required 2-way (500, 700, 1000) : meter (variable to angle)
 Slide rail required 2-way (500, 700, 1000): meter (variable to angle)

FU Vertical Bend 5°

FUVB-5R400

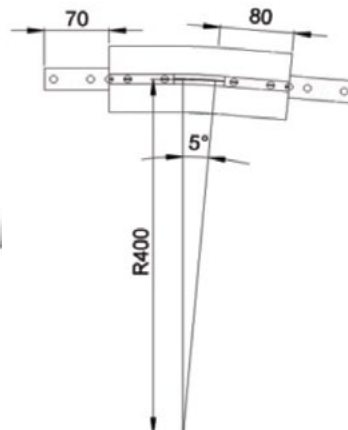
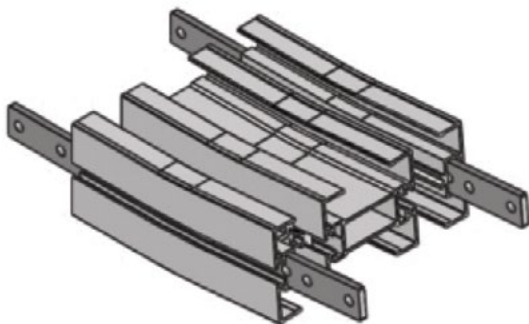

UOM: pc

Chain required 2-way: 0.4 meter
 Slide rail required 2-way: 1.2 meter

FU Vertical Bend 10°

FUVB-10R400

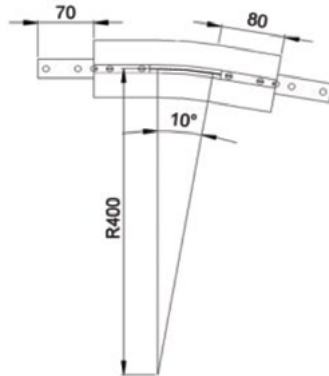
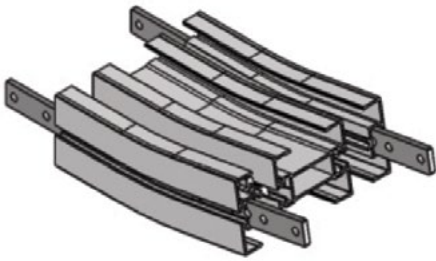

UOM: pc

Chain required 2-way: 0.5 meter
Slide rail required 2-way: 1.4 meter

FU Vertical Bend 15°

FUVB-15R400

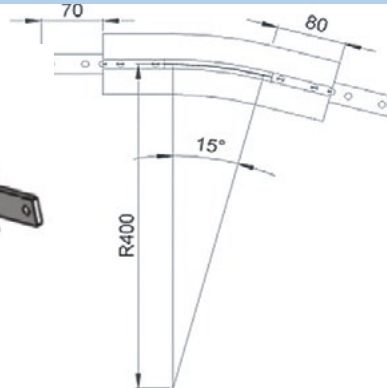
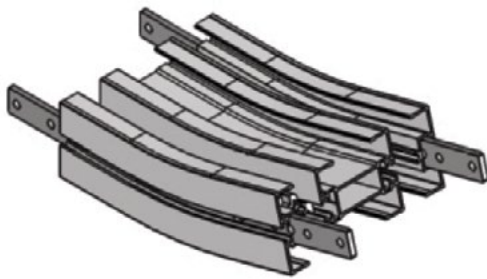

UOM: pc

Chain required 2-way: 0.5 meter
Slide rail required 2-way: 1.6 meter

FU Vertical Bend 20°

FUVB-20R400

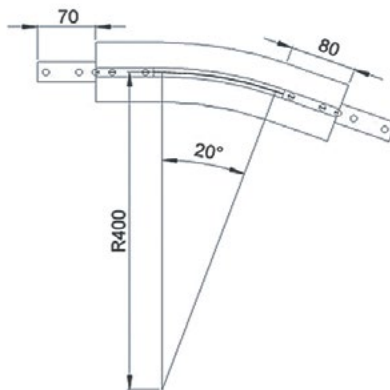
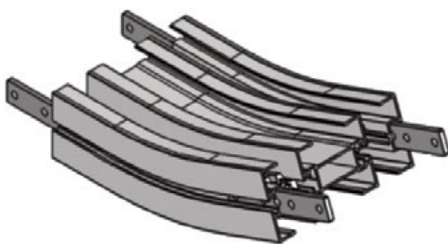

UOM: pc

Chain required 2-way: 0.6 meter
Slide rail required 2-way: 1.8 meter

FU Vertical Bend 30°

FUVB-30R400

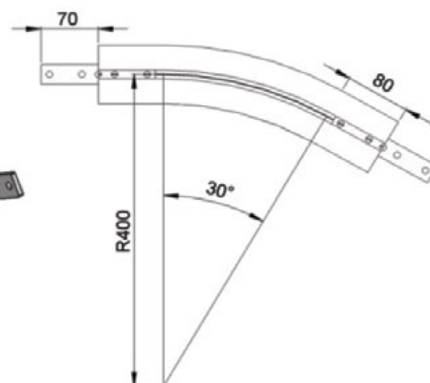
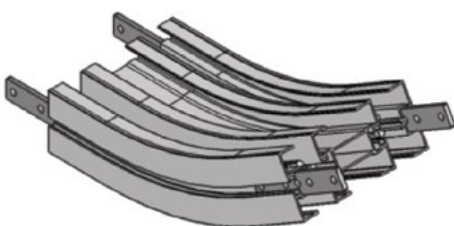

UOM: pc

Chain required 2-way: 0.7 meter
Slide rail required 2-way: 2.2 meter

FU Vertical Bend 45°

FUVB-45R400

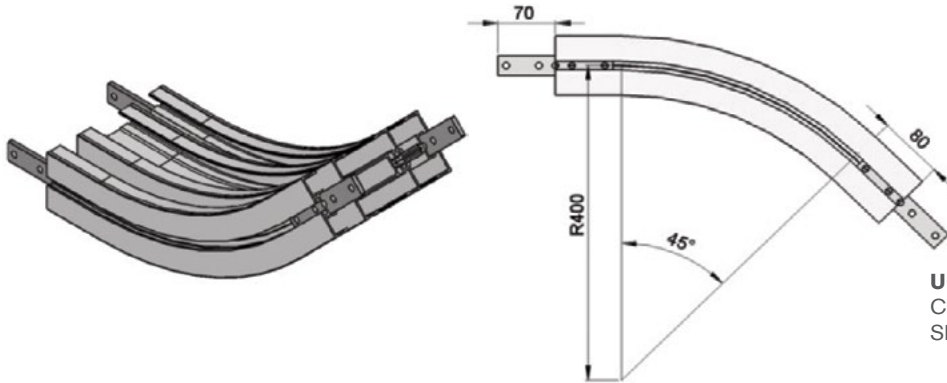

UOM: pc
 Chain required 2-way: 0.9 meter
 Slide rail required 2-way: 2.8 meter

FU Vertical Bend 60°

FUVB-60R400

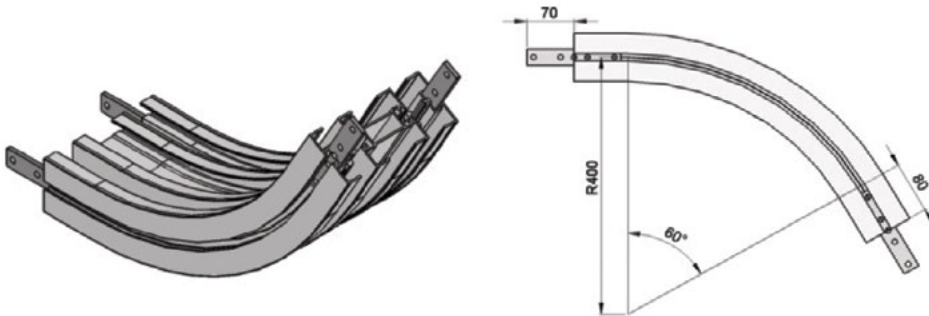

UOM: pc
 Chain required 2-way: 1.2 meter
 Slide rail required 2-way: 3.5 meter

FU Vertical Bend 90°

FUVB-90R400

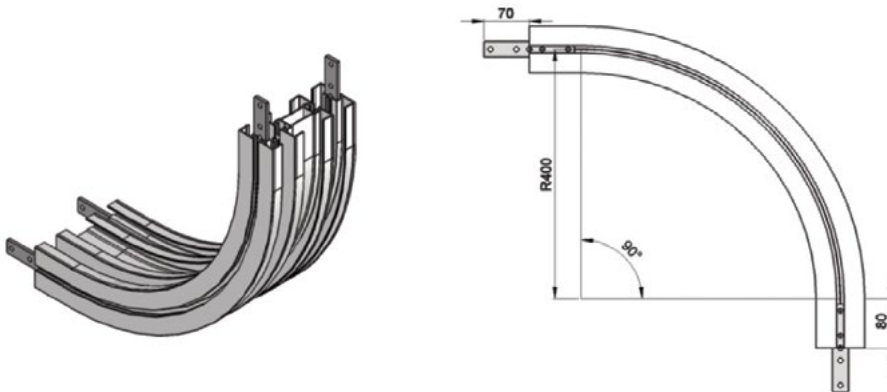

UOM: pc
 Chain required 2-way: 1.6 meter
 Slide rail required 2-way: 4.7 meter

FU Vertical Bend 5°-90°

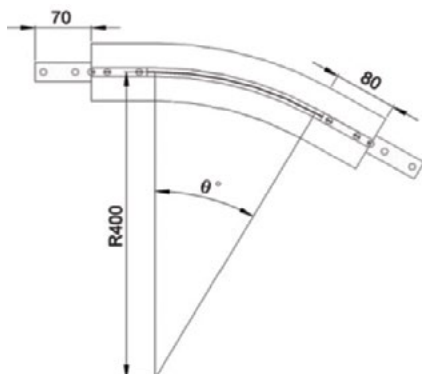

Example for FU Vertical Bend Ordering

- Vertical bend, $\theta^\circ \pm 1^\circ$
- FUVB- θ° R400

If an angle of 65° is needed for vertical bend, the ordering part number is

FUVB-65R400

*The outer bend is assembled using connecting strip (FACS-25x140A).
 Angle of " θ° " must be indicated when ordering.*

FU 45 Degree Twist Conveyor Beam (Clockwise)

FUTB-CW45x3000

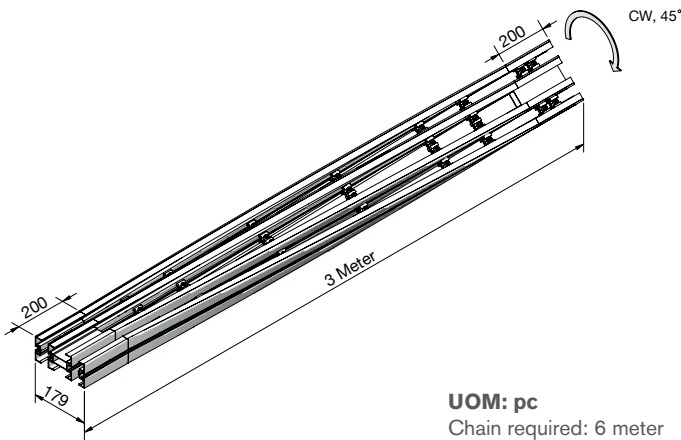

UOM: pc
Chain required: 6 meter
Slide rail required: 12 meter

FU 45 Degree Twist Conveyor Beam (Counter-Clockwise)

FUTB-CCW45x3000

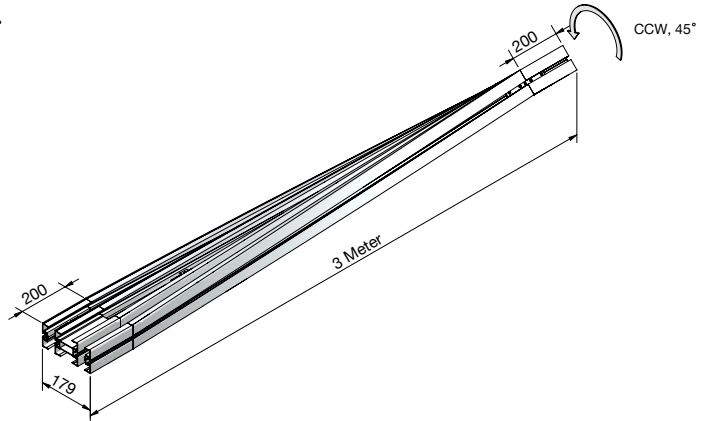

FU 90 Degree Twist Conveyor Beam (Clockwise)

FUTB-CW90x3000

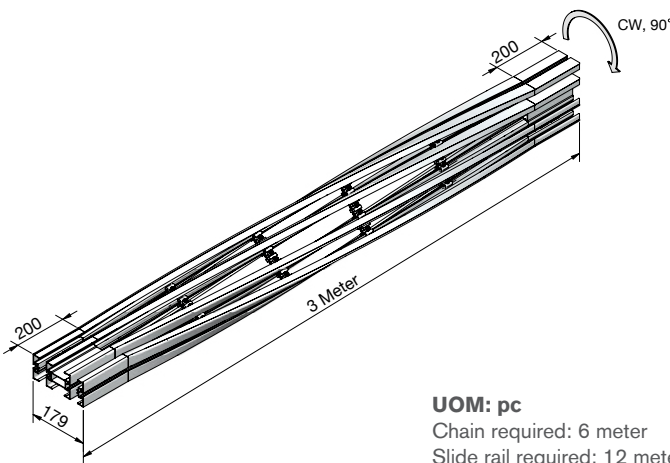

UOM: pc
Chain required: 6 meter
Slide rail required: 12 meter

FU 90 Degree Twist Conveyor Beam (Counter-Clockwise)

FUTB-CCW90x3000

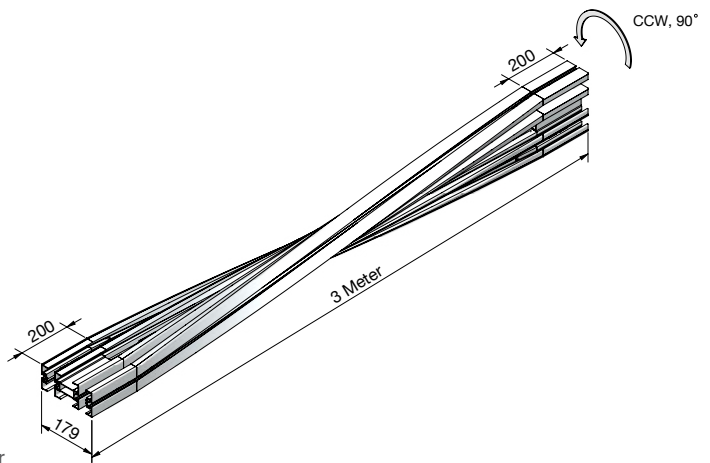

FU Twist Conveyor Beam 15° - 90°

FUTB-AAABBx3000

Where AAA = CW or CCW, BB = Angle

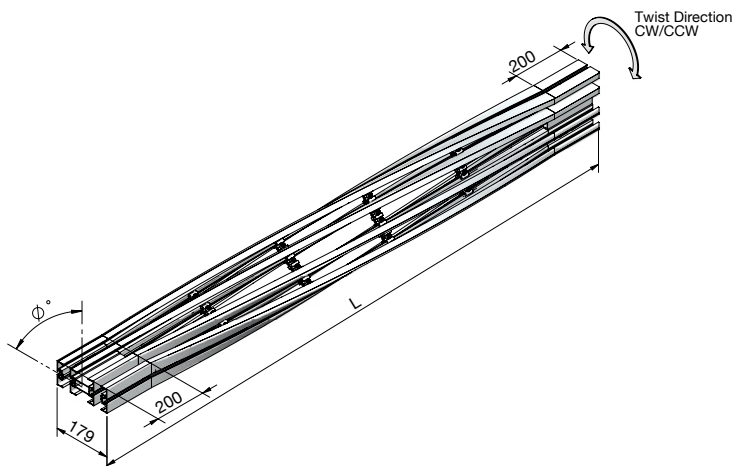

Example for FU Twist Conveyor Beam Ordering

- Twist Conveyor Beam, $\emptyset^\circ \pm 5^\circ$

If an angle of 30° is needed for twist beam, in clockwise direction and length 3.0 m, the ordering part number is

FUTB-CW30x3000

Angle of \emptyset° , twist direction, and length L , must be indicated when ordering.

UOM: pc
Chain required: 6 meter
Slide rail required: 12 meter

FU S In-Line Transfer Module

FUST-180

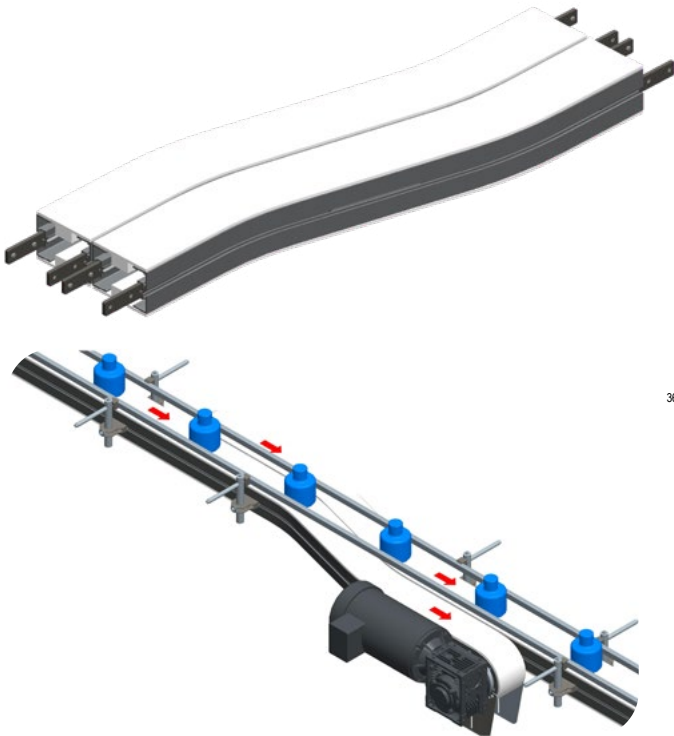

- S In-Line Modules provide a standard, compact way to side transfer product from conveyor to conveyor.
- Straight guiding is placed across the transfer module for smooth In-Line product flow
- Conveyors are mounted together to provide a smooth transfer even for small products
- S In-Line transfers are compact in the width dimension

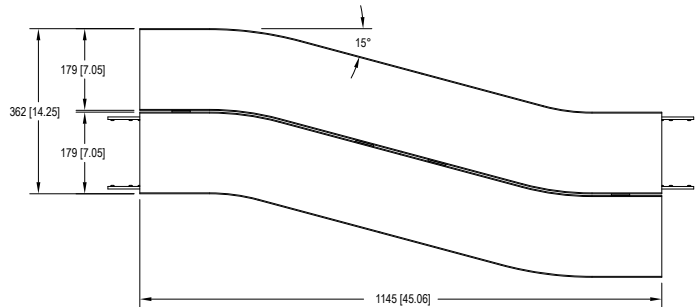

FU X In-Line Transfer Module

FUXT-180



- X In-Line Modules provide a standard, compact way to side transfer product from conveyor to conveyor.
- Straight guiding is placed across the transfer module for smooth In-Line product flow
- Conveyors are mounted together to provide a smooth transfer even for small products
- X In-Line transfers are compact in the length direction

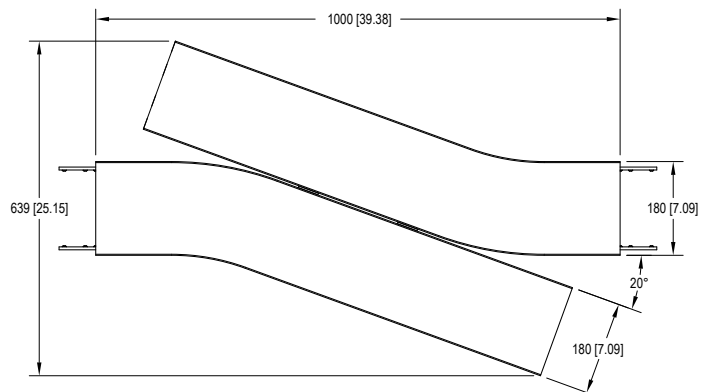

Variety of chain type suitable for wide range of applications either horizontal or vertical product transportation. The maximum product width to be conveyed can be referred to guide rail assembly pages.

FV Series Characteristic

Beam Width: 260 mm

Product Width: Refer to Guide Rail Assembly

Accessories Needed

Slide Rail Required: FASR-25, FASR-25U, FASR-25X

Slide Rail Color: White or Natural Color

Slide Rail Material: HDPE, UHMW OR SPECIAL PE

Slide Rail Rivet & Screw: FASLR-4X6 or FASLS-M5

Connecting strip is used to connect two beams.

Connecting Strip: FACS-25x140A

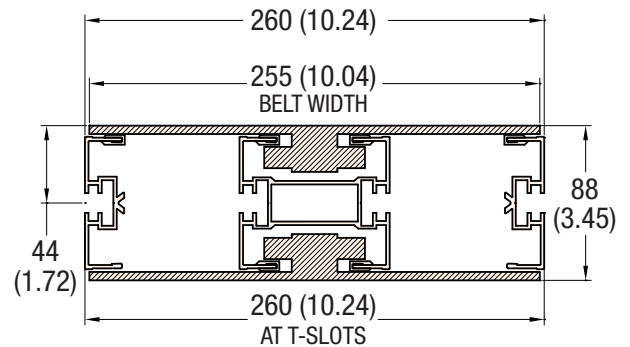

260 MM WIDTH

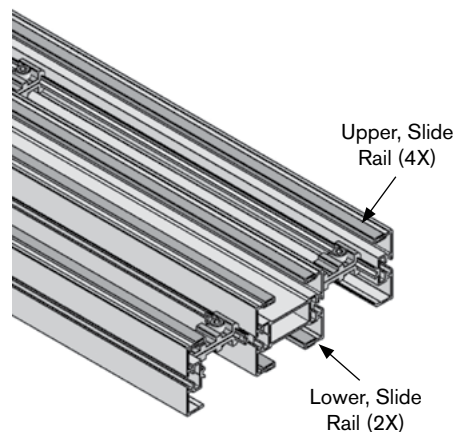
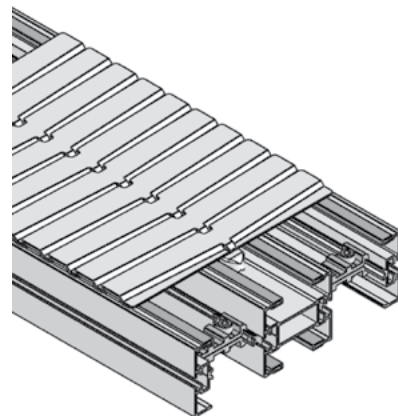

Conveyor Beam **FVCB-3**

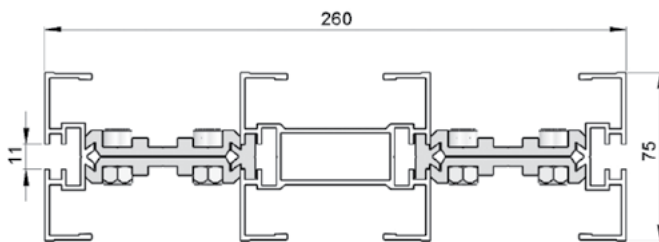

UOM: 3 Meter / Length

Chain Connecting Module **FVCC-300**

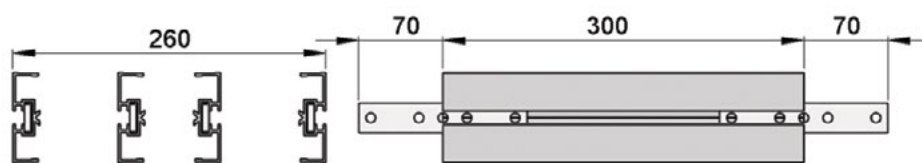

Beam section for chain installation.

UOM: pc

Chain Common Data

Packaging: 5 m per box

Pitch: 33.5 mm

Width: 255 mm

Tensile Strength at 20°C: 6000N

Color: White

Material:

Chain: White Acetal / POM

Pivot: Polyamide

Pivot Pin: Stainless Steel

Insert (Wedge & Friction): TPE Grey

Plain Chain **FVPC-5**

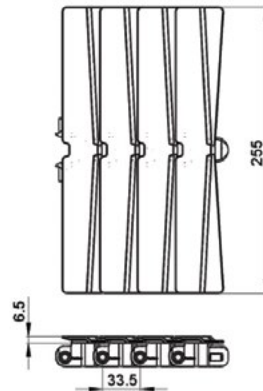
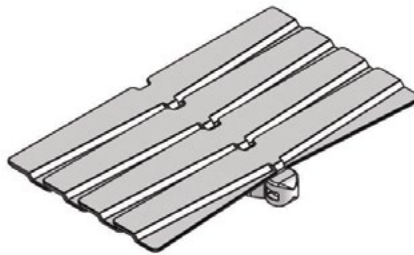

UOM: 5 Meter / box

Application: Suitable for horizontal and slope < 5° transport of products with accumulation.

Roller Plain Chain **FVPC-5R**

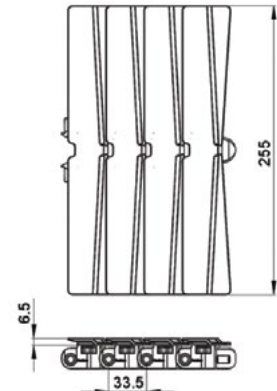
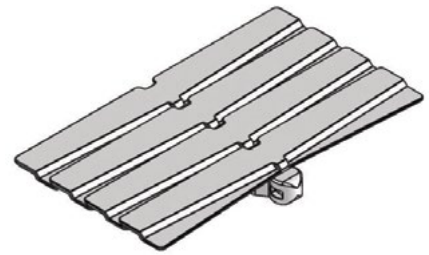

UOM: 5 Meter / box

Application: Suitable for horizontal and slope < 5° transport of products with accumulation.

Note: Friction Reducing Roller Chain Recommended for high speed or high load plain bends

Friction Top Chain **FVFT-B-5**

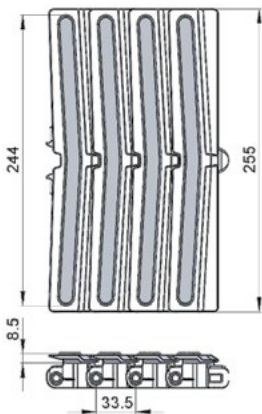
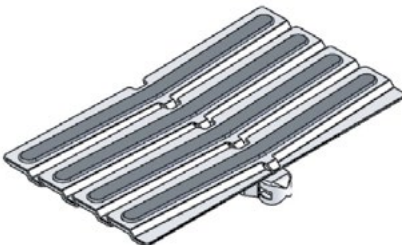

UOM: 5 Meter / box

Application: Suitable for horizontal and slope ≤ 30° transport of products without accumulation.

Roller Friction Top Chain **FVFT-B-5R**

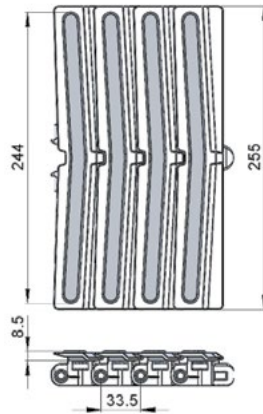
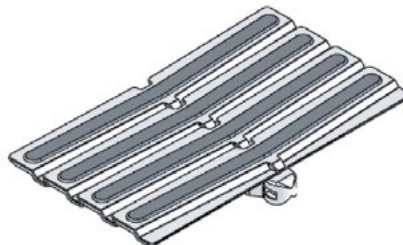

UOM: 5 Meter / box

Application: Suitable for horizontal and slope ≤ 30° transport of products without accumulation.

Note: Friction Reducing Roller Chain Recommended for high speed or high load plain bends

Twist Chain **FVPC-5M**

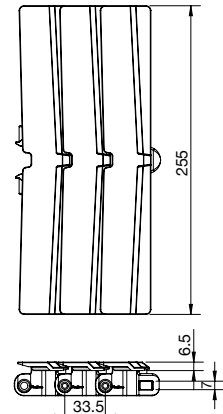
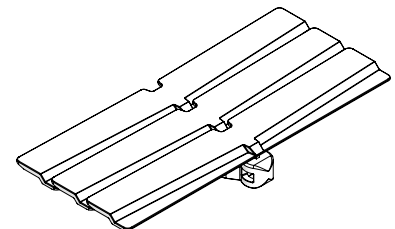

UOM: 5 Meter / box

Application: Suitable twist conveyor beam; horizontal and slope < 5° transport of products with accumulation.

FV Direct End Drive with Motor (LEFT)

FVDD-A260-XDY (See Chart)

FV Suspended Drive with Motor (RIGHT)

FVDD-A260-XDY (See Chart)

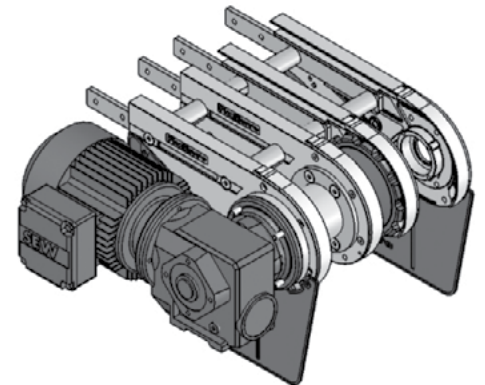
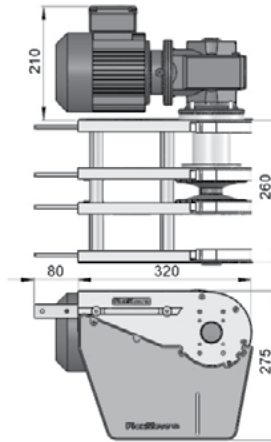
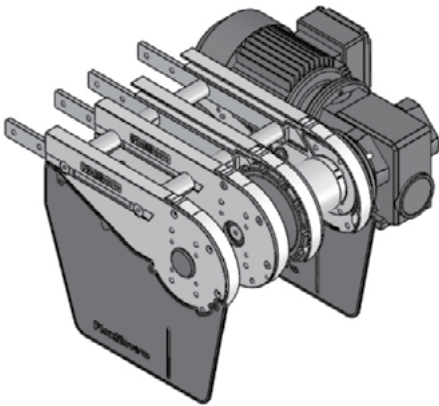

Part Number		Shaft Selection	Direction	Aux Shaft Selection
FVDD-A260	-	X	D	Y
		0 = 20 mm	L = Left	Blank = No Aux Shaft
		E = 3/4 in*	R = Right	A = 20 mm Aux Shaft
		A = 20 mm Aux Only		

*3/4 inch shaft option available in North America only.

Max Traction Force: 1250N

The Direct End Drive Unit is without torque limiter.

UOM: pc

Chain required 2-way: 0.8 meter
Slide rail required 2-way: 0 meter

FV Direct End Drive unit without Motor GP (LEFT)

FVDD-A260GP-XDY (See Chart)

FV Direct End Drive unit without Motor GP (RIGHT)

FVDD-A260GP-XDY (See Chart)

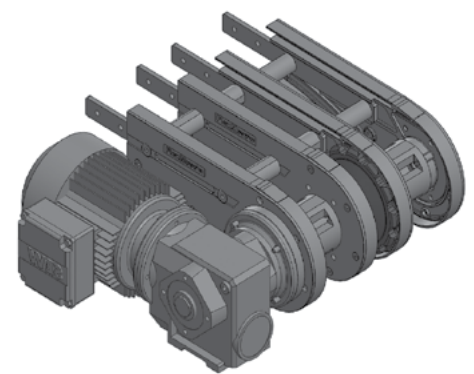
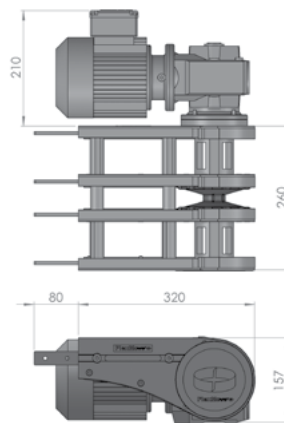
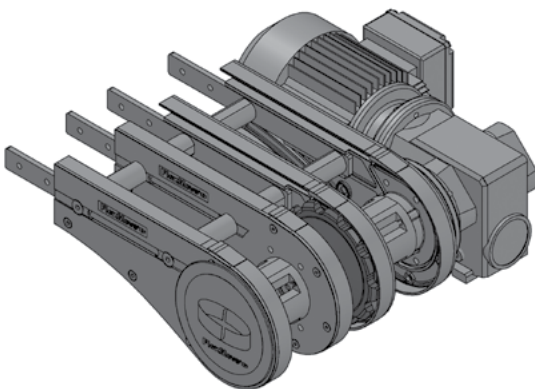

Requires the use of connecting or weighted take-up module for chain maintenance.

Part Number		Shaft Selection	Direction	Aux Shaft Selection
FVDD-A260GP	-	X	D	Y
		0 = 20 mm	L = Left	Blank = No Aux Shaft
		E = 3/4 in*	R = Right	A = 20 mm Aux Shaft
		A = 20 mm Aux Only		

*3/4 inch shaft option available in North America only.

Max Traction Force: 1250N

The Direct End Drive Unit GP is without torque limiter.

UOM: pc

Chain required 2-way: 0.8 meter
Slide rail required 2-way: 0 meter

FV Direct with Power Transfer Motor (LEFT)

FVDD-A260PT-XD (See Chart)

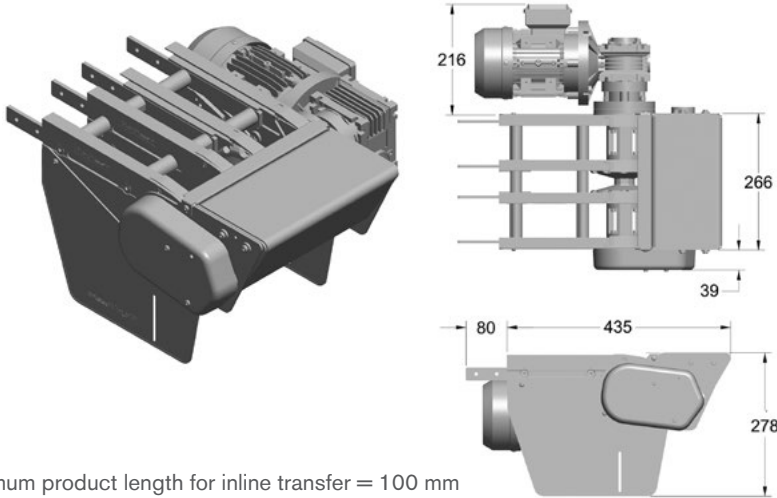

Minimum product length for inline transfer = 100 mm
Maximum speed is 30 m/min (100 ft/min)

Only one power transfer needed on either infeed or discharge trail required for end to end transfer. Provides extended transfer nose for interfacing with large rollers.

Part Number		Shaft Selection	Direction
FVDD-A260PT	-	X	D
		0 = 20 mm	L = Left
		E = 3/4 in*	R = Right

*3/4 inch shaft option available in North America only.

FV Direct with Power Transfer Motor (RIGHT)

FVDD-A260PT-XD (See Chart)

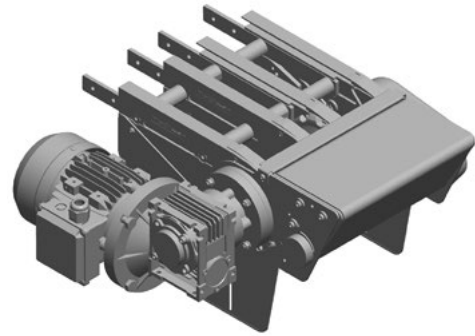

Max Traction Force: 1250N

The Direct End Drive Unit is without torque limiter.

UOM: pc

Chain required 2-way: 0.8 meter
Slide rail required 2-way: 0 meter

FV GP Direct with Power Transfer Motor (LEFT)

FVDD-A260GPPT-XD (See Chart)

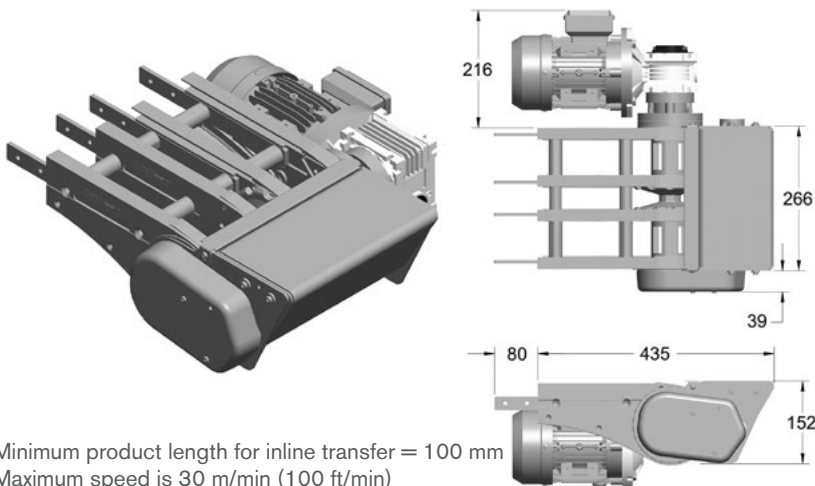

Minimum product length for inline transfer = 100 mm
Maximum speed is 30 m/min (100 ft/min)

Only one power transfer needed on either infeed or discharge trail required for end to end transfer. Provides extended transfer nose for interfacing with large rollers. Requires the use of connecting or weighted take-up module for chain maintenance.

Part Number		Shaft Selection	Direction
FVDD-A260GPPT	-	X	D
		0 = 20 mm	L = Left
		E = 3/4 in*	R = Right

*3/4 inch shaft option available in North America only.

FV GP Direct with Power Transfer Motor (RIGHT)

FVDD-A260GPPT-XD (See Chart)

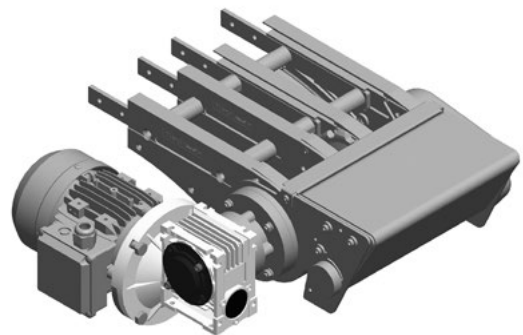

Max Traction Force: 1250N

The Direct End Drive Unit GP is without torque limiter.

UOM: pc

Chain required 2-way: 0.8 meter
Slide rail required 2-way: 0 meter

SEW gearmotors are products of SEW Eurodrive

FV Direct Drive Driven Transfer Bridge (LEFT)

FVDD-A260DB-A-0L

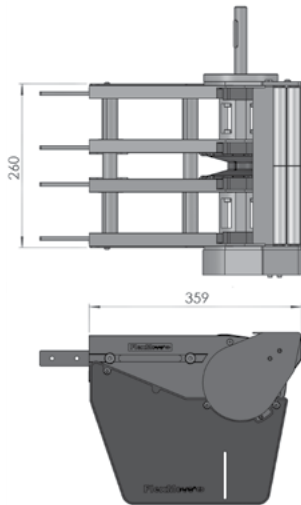

UOM: pc

20 mm Shaft only.
Minimum product length for inline transfer = 100 mm
Transfer extends past conveyor only 27 mm

FV Direct Drive Driven Transfer Bridge (RIGHT)

FVDD-A260DB-A-0R

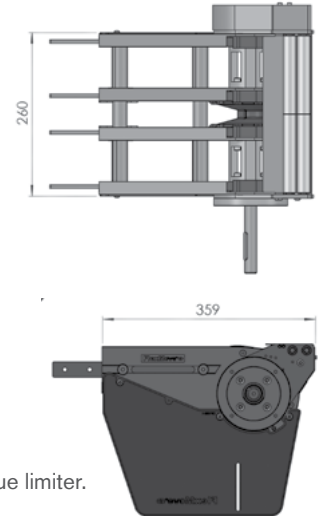

Max Traction Force: 1250N

The Direct End Drive Unit is without torque limiter.

UOM: pc

Chain required 2-way: 0.8 meter
Slide rail required 2-way: 0 meter

FV Direct Drive Free Roller Transfer Bridge (LEFT/ RIGHT)

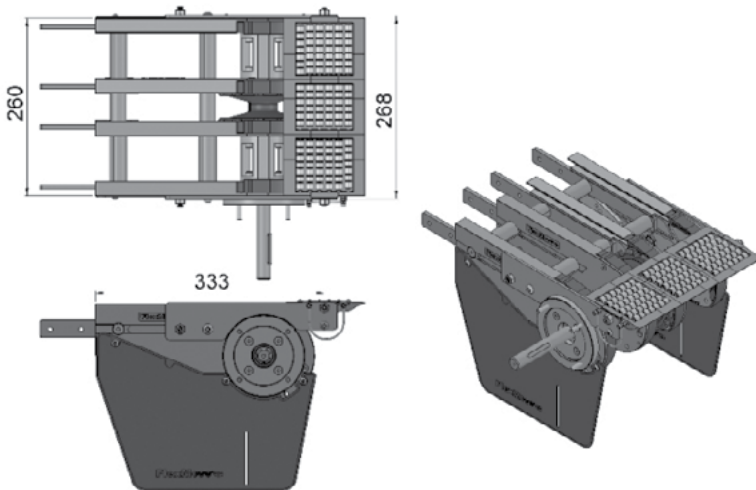

UOM: pc

FVTB-A260

Transfer bridge c/w roller for FVIE-A260, FVDD-A260-XDY and FVDD-A260GP-XDY

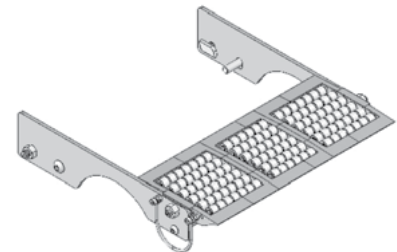

UOM: pc

FV Direct Drive End Free Roller Bridge (LEFT/ RIGHT)

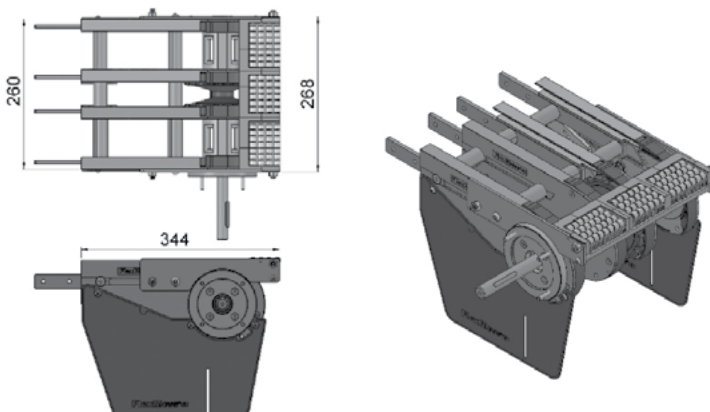

UOM: pc

FVEB-A260

End transfer bridge c/w roller for FVIE-A260, FVDD-A260-XDY and FVDD-A260GP-XDY

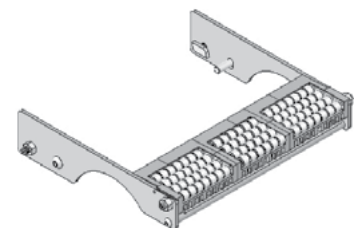

UOM: pc

SEW gearmotors are products of SEW Eurodrive

FV Suspended End Drive with Motor (LEFT)

FVSD-A260-0L (with Torque Limiter)
FVSD-A260SPT-0L (without Torque Limiter)

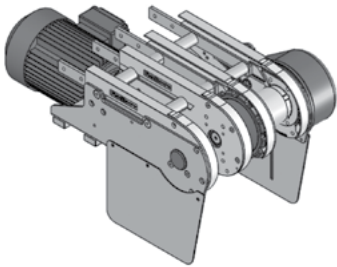

- Locates gearmotor below conveyor for compact applications.
- Includes torque limiter protecting chain and motor from overload.
- Chain pull capacity at 1250N for unit without torque limiter.
- Chain pull capacity at 840N for unit with torque limiter.

FV Suspended End Drive with Motor (RIGHT)

FVSD-A260-0R (with Torque Limiter)
FVSD-A260SPT-0R (without Torque Limiter)

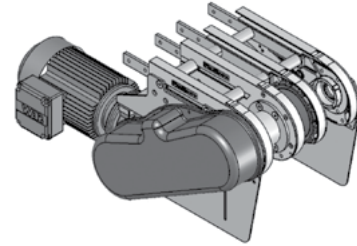

Max Traction Force:
1250N (without limiter)
840N (with limiter)

UOM: pc

Chain required 2-way: 0.8 meter
Slide rail required 2-way: 0 meter

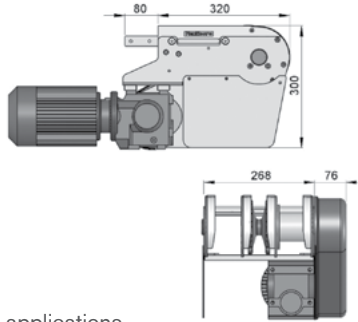

FV Weighted Take-up Module

FV-WTU-700



- Provides automatic chain stretch take-up
- Reduces noise caused from catenary tail
- Must be used with GP Drive End, sold separately
- Used on conveyors over 12 M long

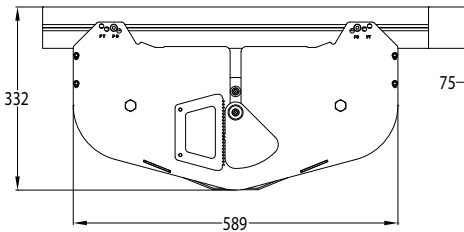
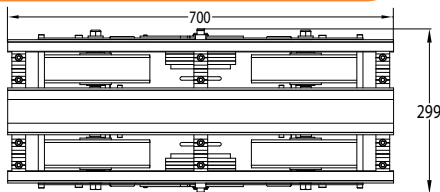

UOM: pc

Chain required 1.5 meter
Slide rail required 3.5 meter

FT Weighted Take-up Tail Module

FT-WTU-260

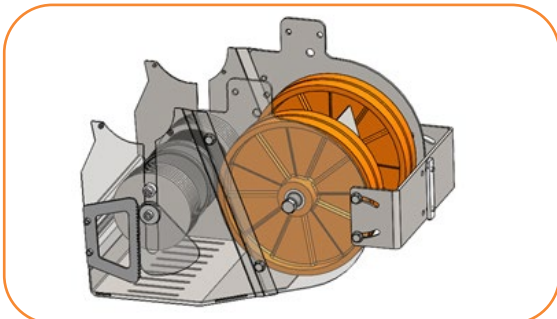

- Provides controlled chain take-up for improved conveyor performance
- Compact design fits in similar space as standard direct drive modules
- Smooths conveyor chain movement by helping to eliminate micro-surfing
- Suggested for conveyors over 12.2 M (40 ft) in length
- Capable of inclined and declined arrangement up to 30 degrees
- Improves operator safety by enclosing chain catenary
- Attaches to direct end drive tail
- Compatible with power transfer and driven bridge

UOM: pc

Chain required 1.5 meter
Slide rail required 2.1 meter

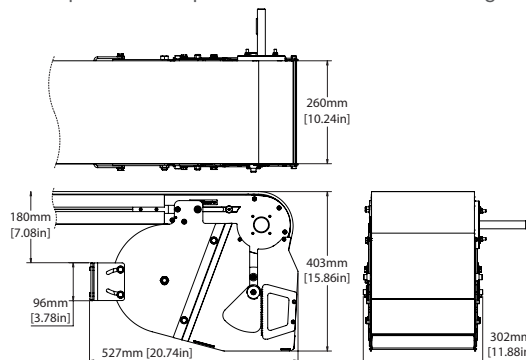

FV Idler End-260

FVIE-A260

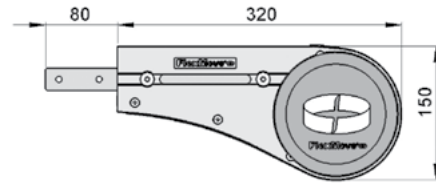
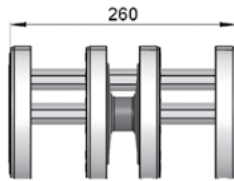
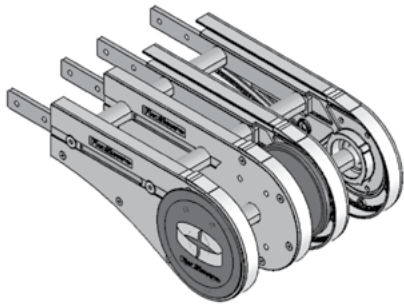

UOM: pc

Chain required 2-way: 0.8 meter
Slide rail required 2-way: 0.5 meter

FV Idler End with Power Transfer (LEFT)

FVIE-A260PT-L

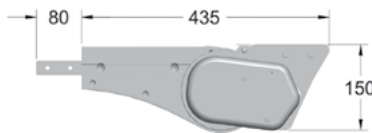
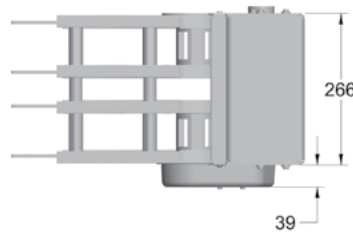
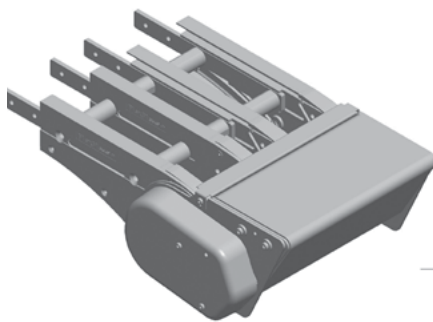

Minimum product length for inline transfer = 100 mm
Provides extended transfer nose for interfacing with large rollers.

FV Idler End with Power Transfer (RIGHT)

FVIE-A260PT-R

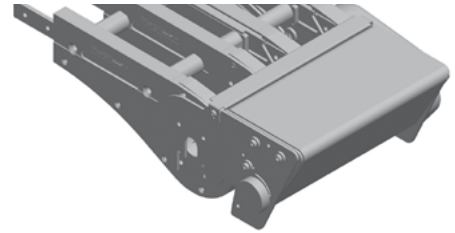

UOM: pc

Chain required 2-way: 0.8 meter
Slide rail required 2-way: 0.5 meter

FV Idler End Driven Transfer Bridge (LEFT)

FVIE-A260DB-A-R

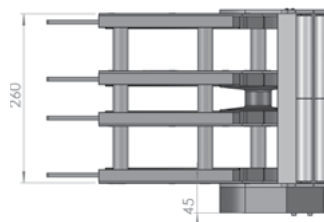
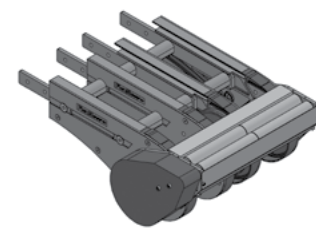
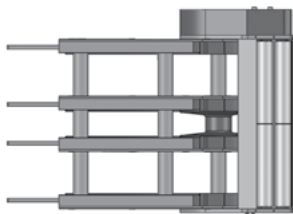

Minimum product length for inline transfer = 100 mm
Transfer extends past conveyor only 27 mm

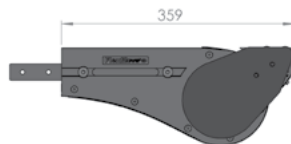

UOM: pc

FV Idler End Driven Transfer Bridge (RIGHT)

FVIE-A260DB-A-L

FV Idler Free Roller Transfer Bridge

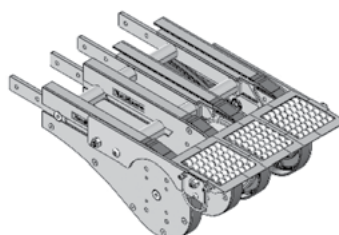
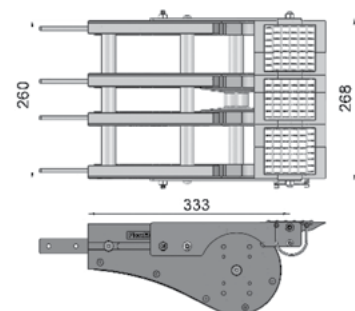

FVTB-A260

Transfer bridge c/w roller for FVIE-A260, FVDD-A260-XDY and FVDD-A260GP-XDY

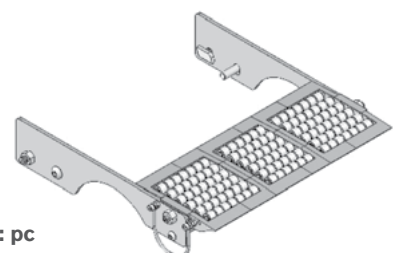

UOM: pc

FV Idler End Free Roller Bridge

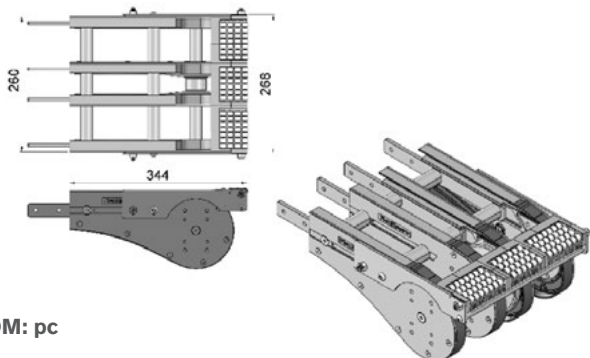

UOM: pc

FVEB-A260

End transfer bridge c/w roller for FVIE-A260, FVDD-A260-XDY and FVDD-A260GP-XDY

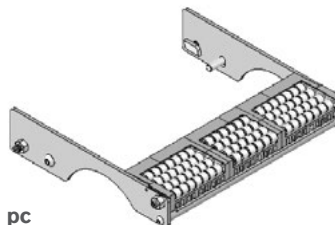

UOM: pc

FV Horizontal Plain Bend 30°

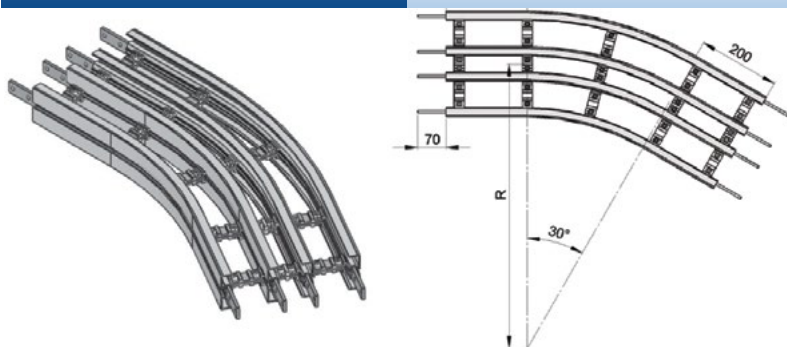

Horizontal plain bend, 30° ± 1°

R = 700 ± 10 mm **FVHB-30R700**

R = 1000 ± 10 mm **FVHB-30R1000**

UOM: pc

Chain required 2-way (700, 1000): 1.5, 1.8 meter
Slide rail required 2-way (700, 1000): 4.6, 5.5 meter

FV Horizontal Plain Bend 45°

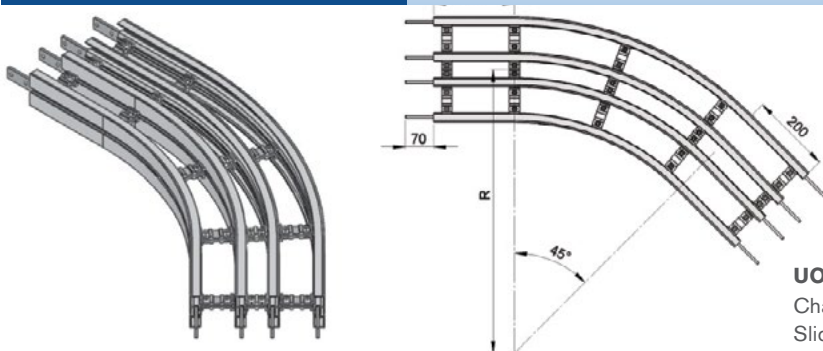

Horizontal plain bend, 45° ± 1°

R = 700 ± 10 mm **FVHB-45R700**

R = 1000 ± 10 mm **FVHB-45R1000**

UOM: pc

Chain required 2-way (700, 1000): 1.9, 2.4 meter
Slide rail required 2-way (700, 1000): 5.7, 7.1 meter

FV Horizontal Plain Bend 60°

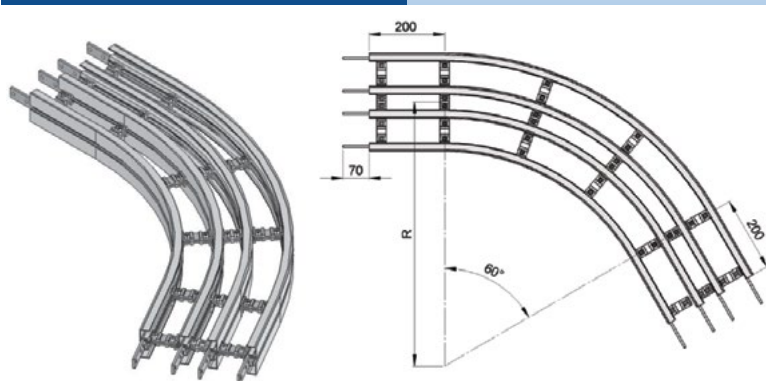

Horizontal plain bend, 60° ± 1°

R = 700 ± 10 mm **FVHB-60R700**

R = 1000 ± 10 mm **FVHB-60R1000**

UOM: pc

Chain required 2-way (700, 1000): 2.3, 2.9 meter
Slide rail required 2-way (700, 1000): 6.8, 8.7 meter

FV Horizontal Plain Bend 90°

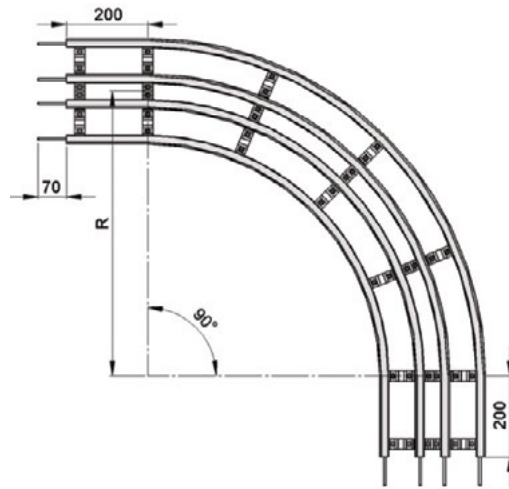

Horizontal plain bend, 90° ± 1°

- R = 700 ± 10 mm **FVHB-90R700**
- R = 1000 ± 10 mm **FVHB-90R1000**

UOM: pc

Chain required 2-way (700, 1000): 3.0, 3.9 meter
 Slide rail required 2-way (700, 1000): 9.0, 11.8 meter

FV Horizontal Plain Bend 5° - 180°

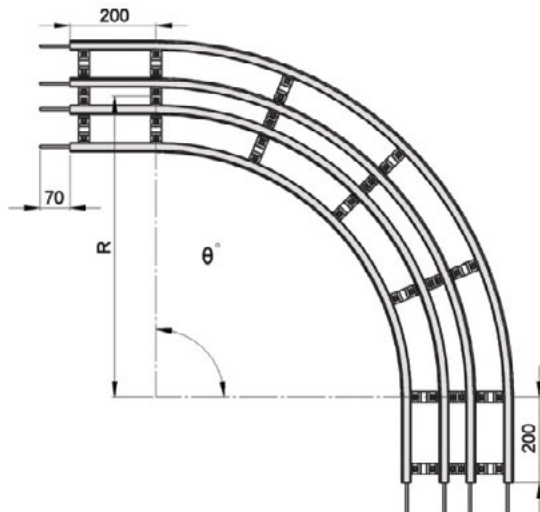

Example for FV Horizontal Plain Bend Ordering

Horizontal plain bend, θ° ± 1°

- R = 700 ± 10 mm **FVHB - θ°R700**
- R = 1000 ± 10 mm **FVHB - θ°R1000**

If an angle of 120° is needed for radius R700 horizontal plain bend, the ordering part number is

FVHB -120R700

UOM: pc

Chain required 2-way (700, 1000): meter (variable to angle)
 Slide rail required 2-way (700, 1000): meter (variable to angle)

FV Vertical Bend 5° FVVB-5R400

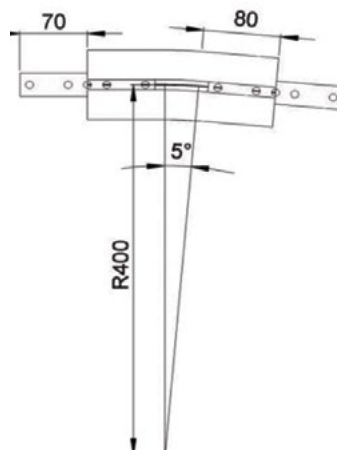
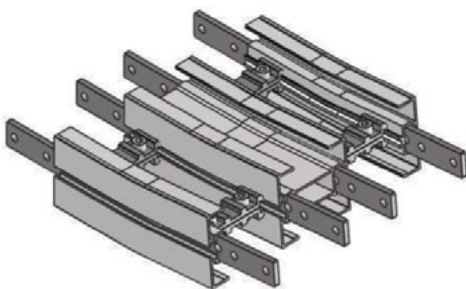

UOM: pc

Chain required 2-way: 0.4 meter
 Slide rail required 2-way: 1.2 meter

FV Vertical Bend 10°

FVVB-10R400

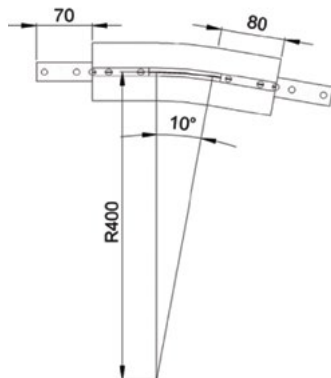
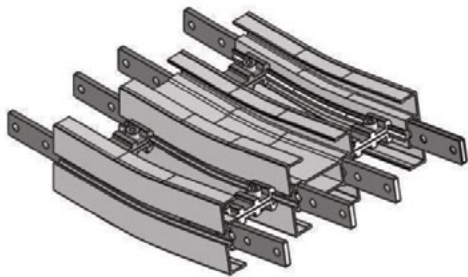

UOM: pc

Chain required 2-way: 0.5 meter
Slide rail required 2-way: 1.4 meter

FV Vertical Bend 15°

FVVB-15R400

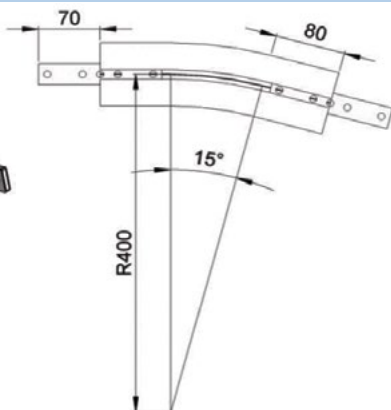
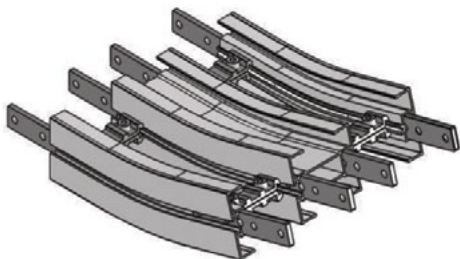

UOM: pc

Chain required 2-way: 0.5 meter
Slide rail required 2-way: 1.6 meter

FV Vertical Bend 20°

FVVB-20R400

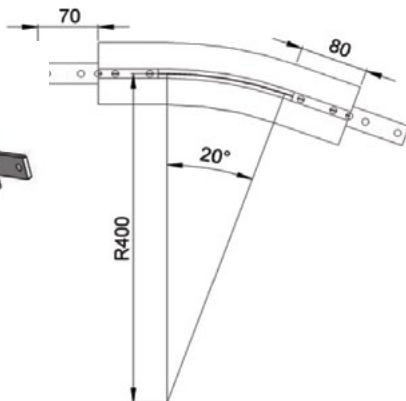
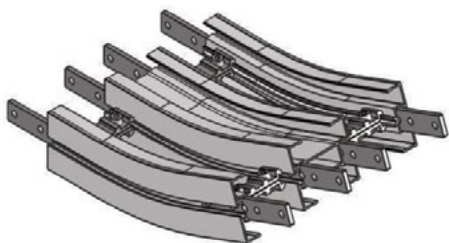

UOM: pc

Chain required 2-way: 0.6 meter
Slide rail required 2-way: 1.8 meter

FV Vertical Bend 30°

FVVB-30R400

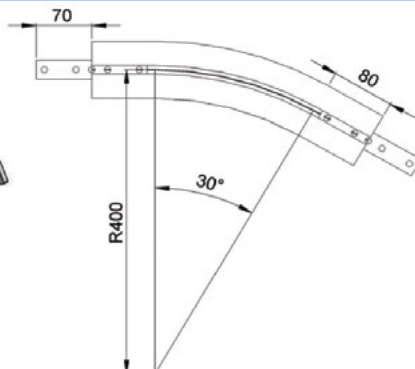
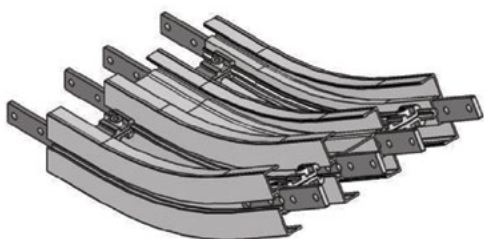

UOM: pc

Chain required 2-way: 0.7 meter
Slide rail required 2-way: 2.2 meter

FV Vertical Bend 45°

FVVB-45R400

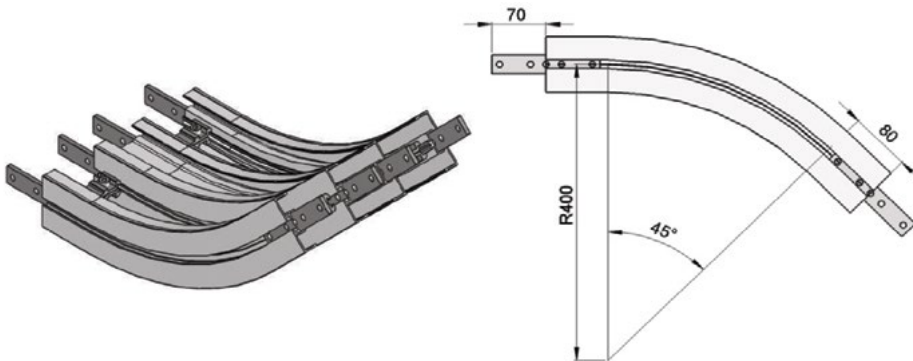

UOM: pc

Chain required 2-way: 0.9 meter
Slide rail required 2-way: 2.8 meter

FV Vertical Bend 60°

FVVB-60R400

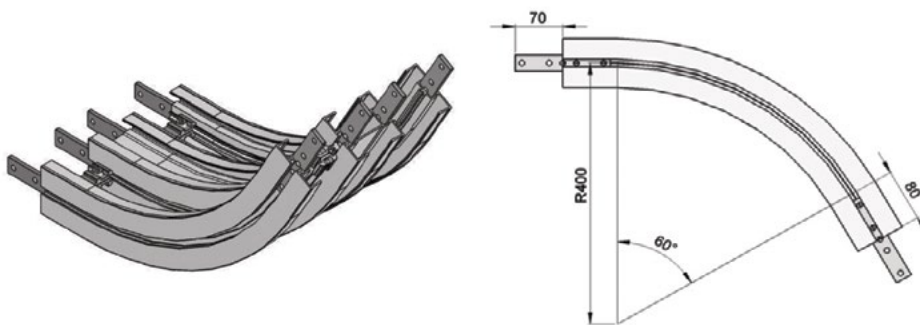

UOM: pc

Chain required 2-way: 1.2 meter
Slide rail required 2-way: 3.5 meter

FV Vertical Bend 90°

FVVB-90R400

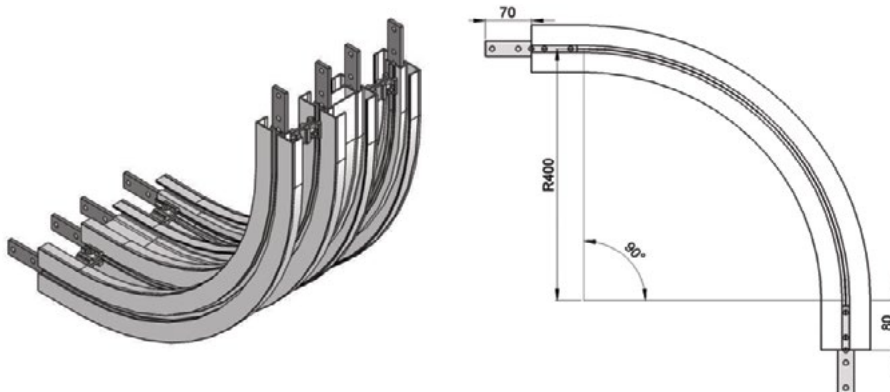

UOM: pc

Chain required 2-way: 1.6 meter
Slide rail required 2-way: 4.7 meter

FV Vertical Bend 5°-90°

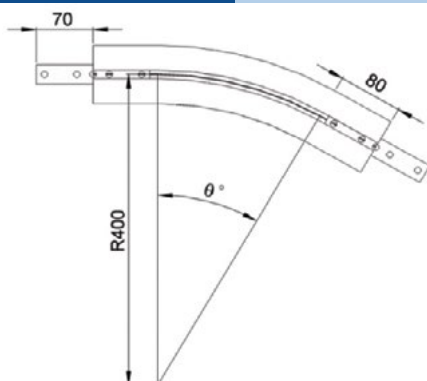

Example for FV Vertical Bend Ordering

- Vertical bend, $\varnothing^\circ \pm 1^\circ$
- FVVB- \varnothing° R400

If an angle of 65° is needed for vertical bend, the ordering part number is

FVVB-65R400

*The outer bend is assembled using connecting strip (FACS-25x140A).
Angle of "∅°" must be indicated when ordering.*

FV 45 Degree Twist Conveyor Beam (Clockwise)

FVTB-CW45x3000

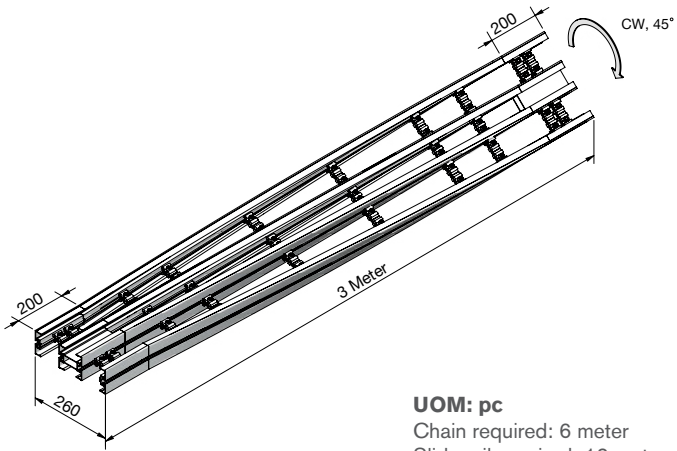

UOM: pc
Chain required: 6 meter
Slide rail required: 12 meter

FV 45 Degree Twist Conveyor Beam (Counter-Clockwise)

FVTB-CCW45x3000

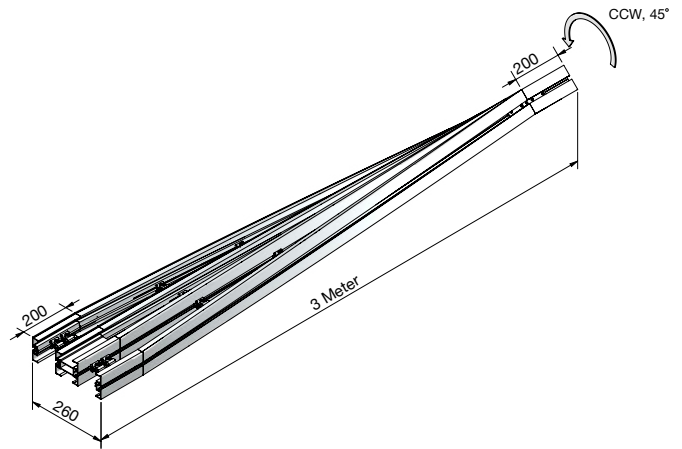

FV Twist Conveyor Beam 15° - 45°

FVTB-AAABx3000

Where AAA = CW or CCW, BB = Angle

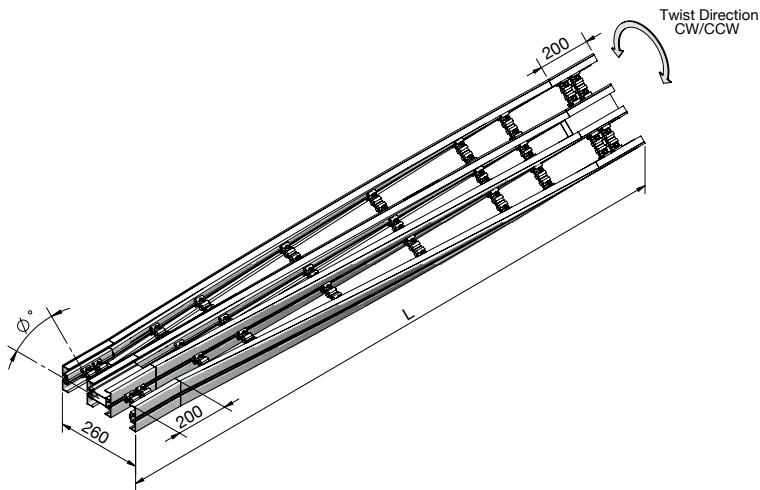

Example for FV Twist Conveyor Beam Ordering

- Twist Conveyor Beam, $\varnothing^\circ \pm 5^\circ$

If an angle of 30° is needed for twist beam, in clockwise direction and length 2.5 m, the ordering part number is

FVTB-CW30x3000

Angle of \varnothing° , twist direction, and length L, must be indicated when ordering.

UOM: pc
Chain required: 6 meter
Slide rail required: 12 meter

FV S In-Line Transfer Module

FVST-260

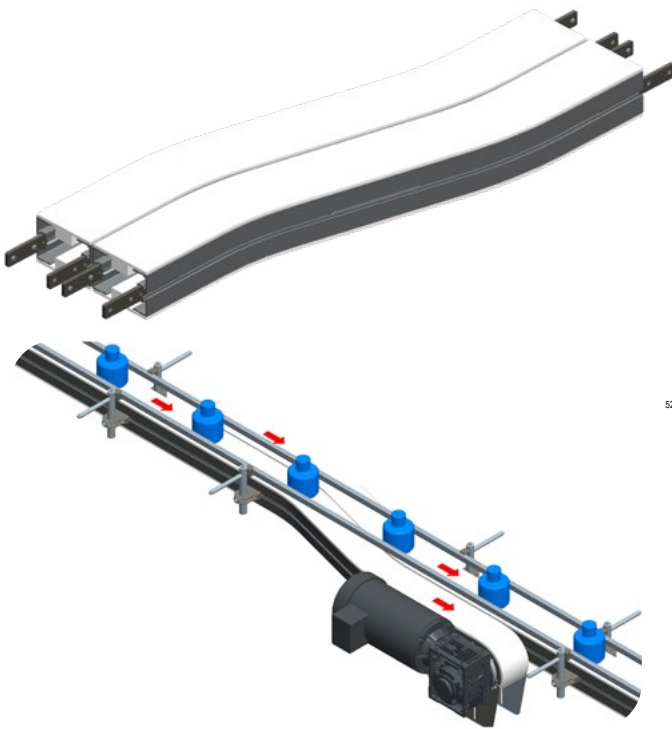

- S In-Line Modules provide a standard, compact way to side transfer product from conveyor to conveyor.
- Straight guiding is placed across the transfer module for smooth In-Line product flow
- Conveyors are mounted together to provide a smooth transfer even for small products
- S In-Line transfers are compact in the width dimension

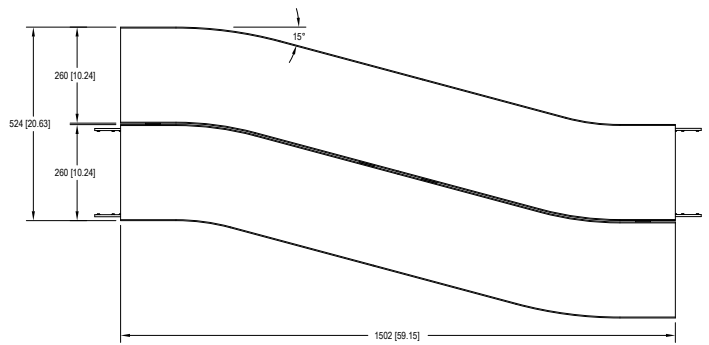

FV X In-Line Transfer Module

FVXT-260

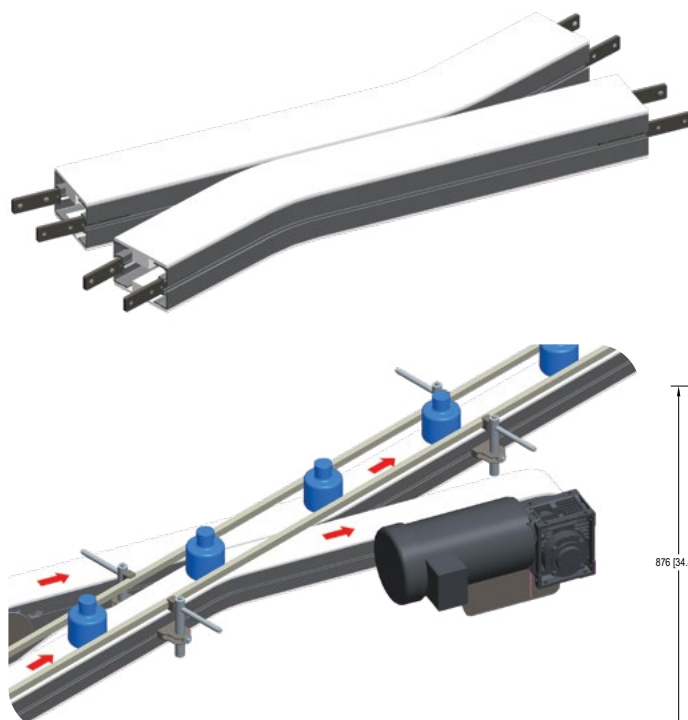

- X In-Line Modules provide a standard, compact way to side transfer product from conveyor to conveyor.
- Straight guiding is placed across the transfer module for smooth In-Line product flow
- Conveyors are mounted together to provide a smooth transfer even for small products
- X In-Line transfers are compact in the length direction

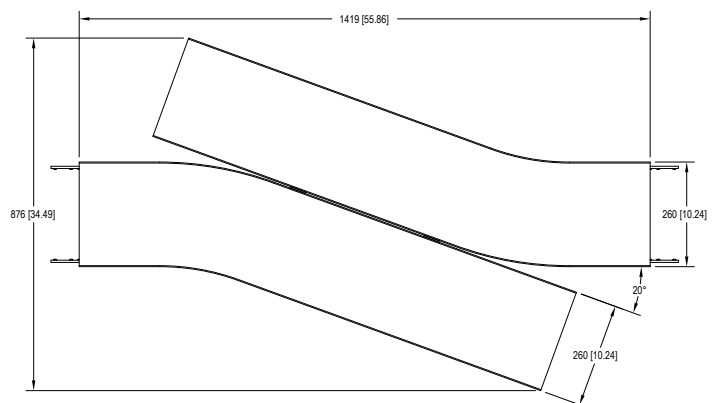

Adjustable Width Wedge Conveyor Components

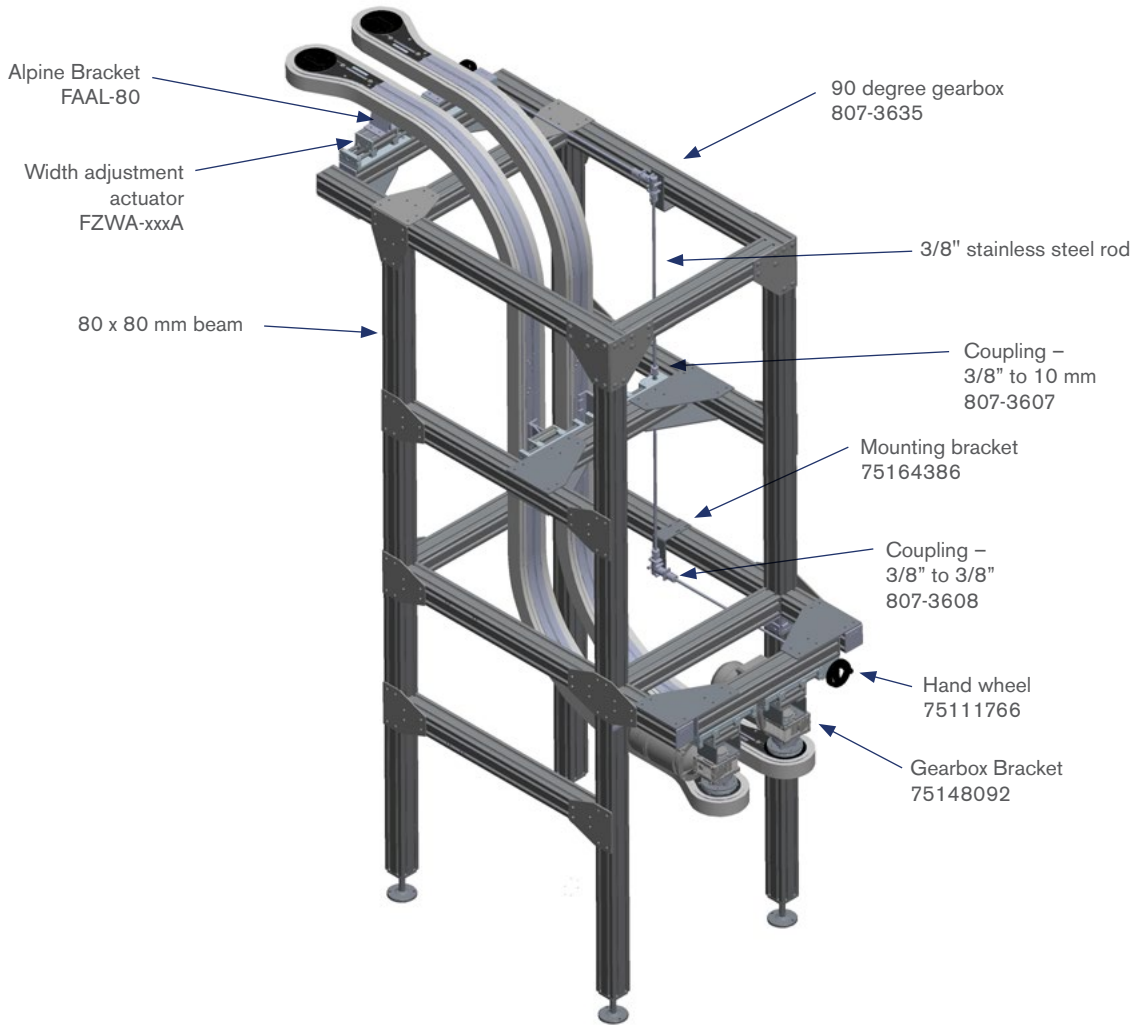

FZWA-660A Width Adjustment Actuator 660 mm

FZWA-950A Width Adjustment Actuator 950 mm

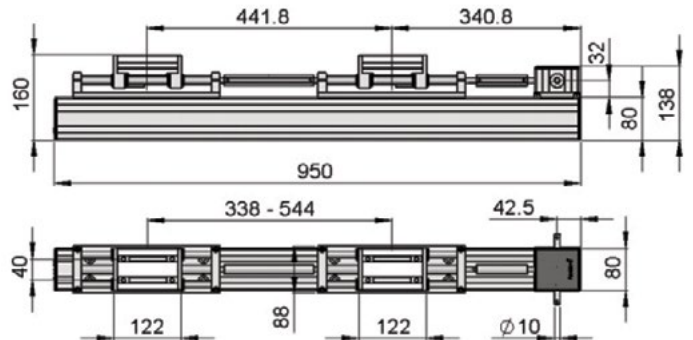
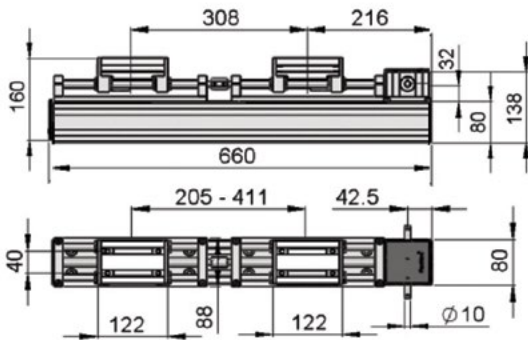

UOM: Unit

UOM: Unit

FZGB-903 Angle Gear Unit-3 direction

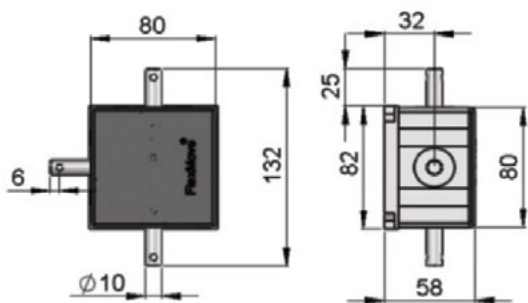

UOM: Unit

807-3635 90° Gearbox

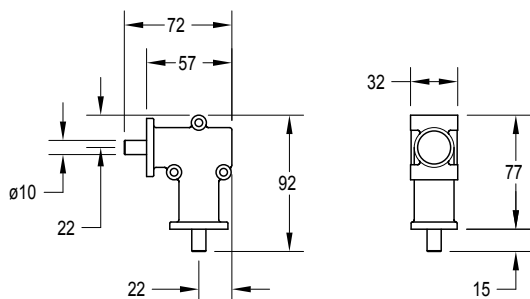

UOM: Unit

807-3609 Couplin 3/8" to 3/8"



UOM: Unit

75111766 Hand Wheel

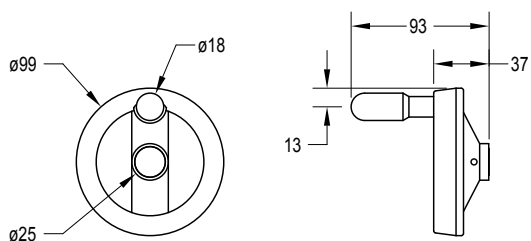

UOM: Unit

FZGB-904 Angle Gear Unit – 4 direction

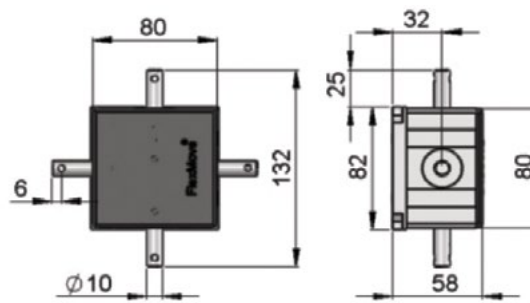

UOM: Unit

75164386 90° Gearbox Mount

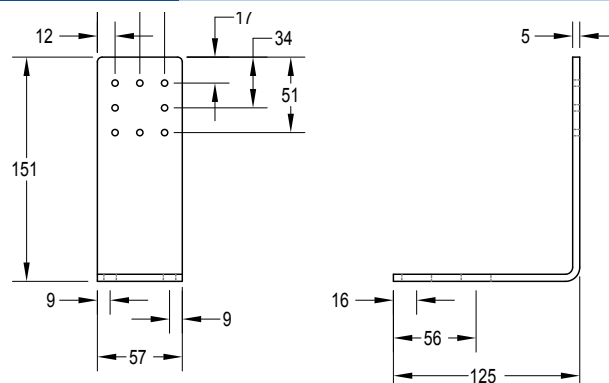

UOM: Unit

807-3607 Coupling 3/8" to 10mm

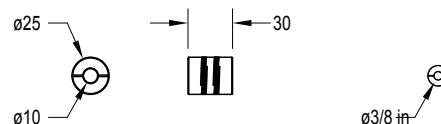

UOM: Unit

75148092 Conveyor Gearbox Mount

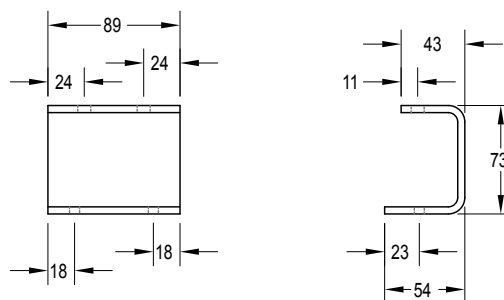

UOM: Unit

CCDW-Sx*

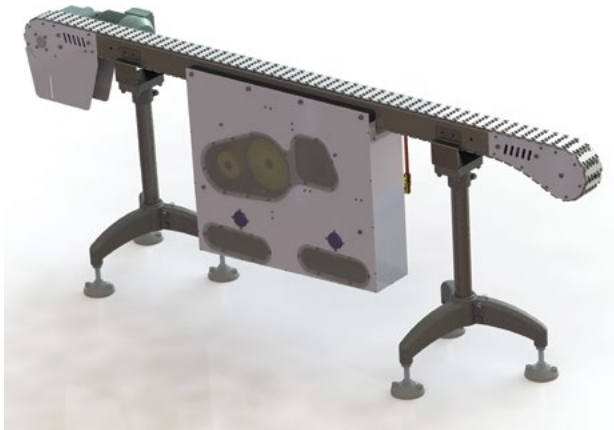

Wet Cleaning Module

- Wet Cleaning Module provides continuous cleaning of conveyor chain for applications with liquid or product overflow or package breakage
- Water jets spray outside and inside of the conveyors chain
- Series Driven Brush scrubs top and bottom surface of chain
- Air knives blow off water from chain
- Vacuum draws away excess water
- Designed to run continuously in production line
- Allows for longer, cleaner production runs with less overall maintenance
- Clean design with minimal area for dirt and debris to accumulate
- Fully encased components with cover designed for worker safety
- Completely mechanical, does not require electrical components, programming or secondary motor

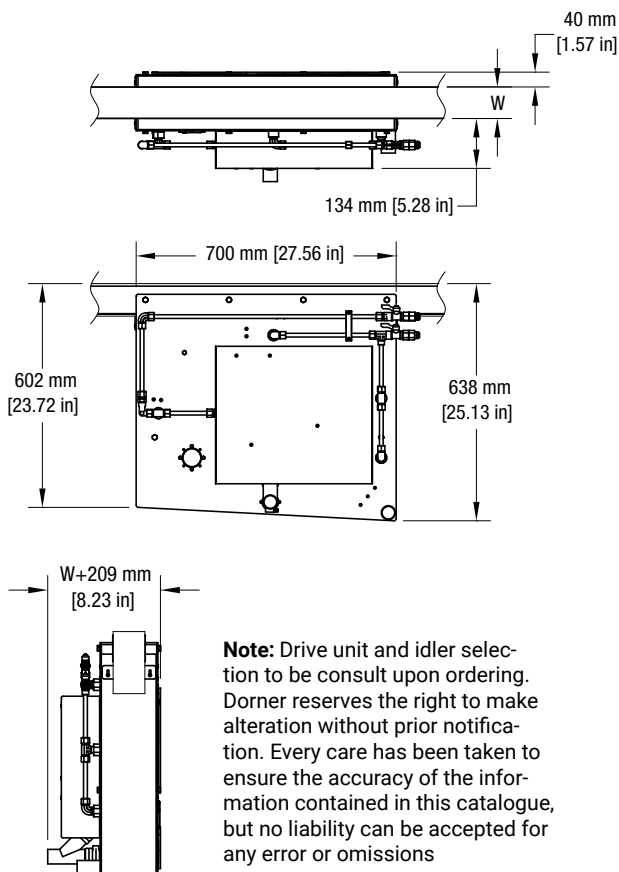

Features

- Available on FlexMove Stainless Steel Conveyors, SS (65 mm) and SM (85 mm)
- Size Requirement: 700 mm (L) x 700 mm (H)
- Minimum top of chain height: 750 mm (29.5 in)
- Maximum conveyor length: 4.5 m (14.8 ft)
- Maximum conveyor speed: 50 m/min (164 ft/min)

Dimensions and Operation Requirements

Water Supply

- Connection 3/8 in NPT
- Normal operating pressure 0.98MPa. (140 psi)
- Flow rate required: ~13 litre/min (0.5 CFM)

Air Supply

- Connection: 8 mm tubing
- Air pressure required: 0.69 MPa (100 PSI)

Drying Vacuum

- Vacuum attachment: OD Ø38 mm, ID Ø34 mm pipe.
- Vacuum airflow required: ~56 litre/s (120 CFM), typical commercial grade wet/dry vacuum is acceptable

*Where Sx = Conveyor series (limit to SS & SM)

CCD-Fx*

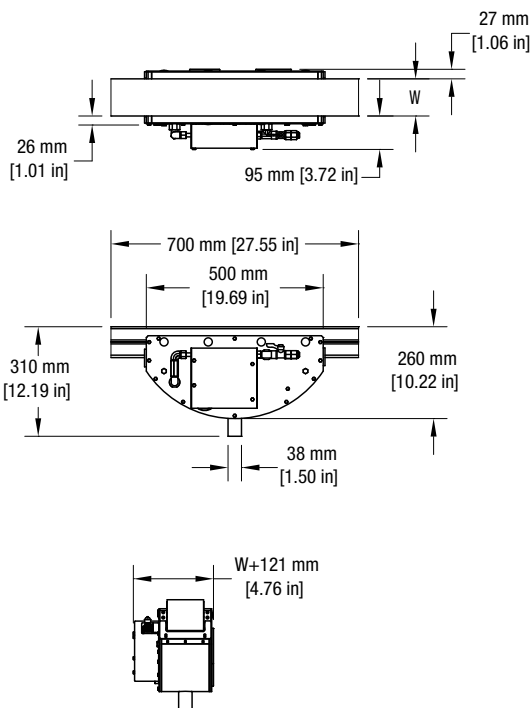
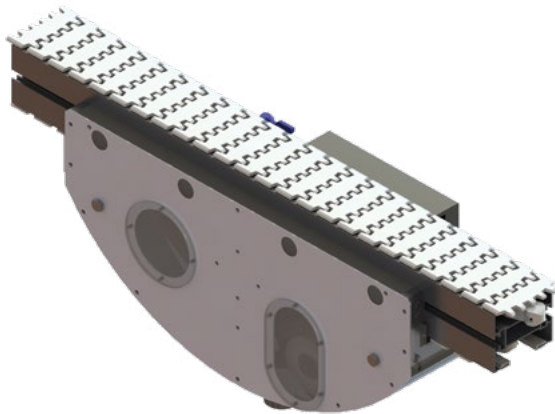

Dry Cleaning Module

- Dry Cleaning Module provides continuous cleaning of conveyor chain for dry applications with powder, dust or other dry contaminants
- Series Driven Rotary Brush scrubs chain surface, compressed air blows off particles, and vacuum extracts dust
- Designed to run continuously in production line
- Allows for longer, cleaner production runs with less overall maintenance
- Clean design with minimal area for dirt and debris to accumulate
- Fully encased components with cover designed for worker safety
- Completely mechanical, does not require electrical components, programming or secondary motor

Features

- Available on FlexMove Aluminum Conveyors, FS (65 mm), FM (85 mm) and FC (150 mm)
- Size Requirement: 700 mm (L) x 300 mm (H)
- Minimum top of chain height: 250 mm (13.8 in)
- Maximum conveyor length: 4.5 m (14.8 ft)
- Maximum conveyor speed: 50 m/min (164 ft/min)

Dimensions and Operation Requirements

Air Supply

- Incoming tubing size: M8
- Normal operating pressure 0.69 MPa (100 PSI)

Drying Vacuum

- Vacuum attachment: OD Ø38 mm, ID Ø34 mm pipe
- Vacuum airflow required: ~56 litre/s (120 CFM)
- Typical commercial grade vacuum is acceptable

*Where Fx = Conveyor series (limit to FS, FM, FC & FU)

FZTC-SA-W_{xxx}*

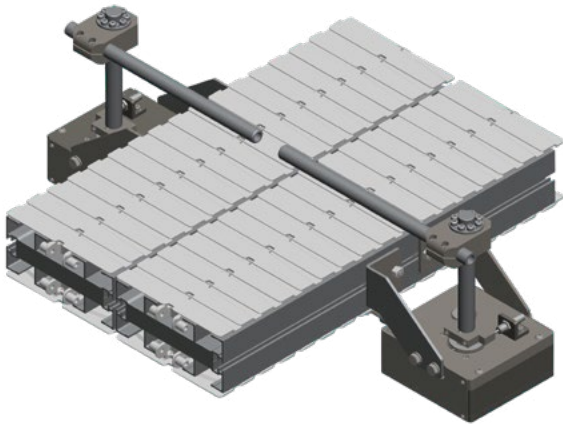

Side Acting Merge Module

- Two-to-one lane merging without the need for control logic
- First in, first out style merge
- Opposite lane will proceed once the first lane exits or large product gap exists
- Activate arm is adjustable in both height and length
- Completely mechanical design, does not require electrical components, programming or air
- Easily modify the force required to activate the divert arm
- Designed for operator safety, no guarding required

Features

- Available on FlexMove Aluminium Conveyors, FS (65 mm), FM (85 mm), FC (105 mm), FL (150 mm), FU (180 mm) and FV (260 mm)
- Product must be able to withstand some back pressure
- Side Acting Merger is not suitable for high speed applications
- Min. Single Product Weight: 0.5 kg
- Max. Single Product Weight: 15 kg
- Max. Product Accumulation Weight: Up to 45 kg

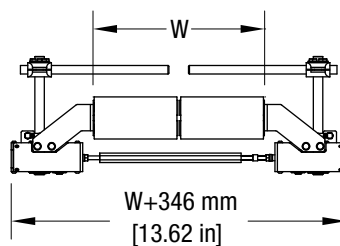
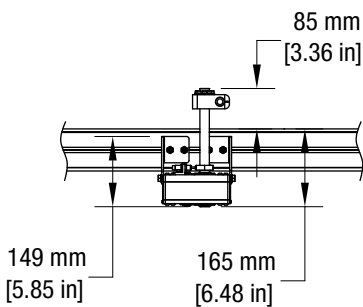
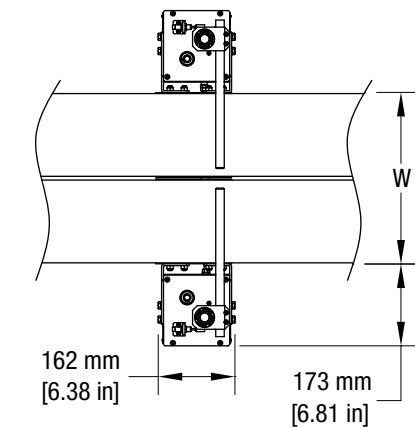

*Where xxx = total width of merge area

208161 & 208169



Puck Stop Module

- Pneumatic stop for pacing pucks or packages
- Two Models:
 - Vertical Blade Stop; used in pairs as an alternating escapement for pacing round or rounded edge rectangular pucks
 - Horizontal Squeeze Stop; used in combination with Vertical Blade Stop for pacing product without rounded edges. Product must be able to withstand side squeeze pressure
- Compatible with round or rectangular bottles, containers or pucks
- UHMW face for non-marking contact surface
- Includes flow controls with push-in air line connection
- Requires photo sensors, pneumatic solenoid valves, wiring and programming
- Rate depends on product size. Contact factory for details

Features

- Available on FlexMove Aluminum Conveyors, FS (65 mm), FM (85 mm), FC (105 mm), FL (150 mm), FU (180 mm), and FV (260 mm)
- Max. single product weight: 2.3 kg (5 lbs)
- Max. product accumulation weight: 13.6 kg (30 lbs)
- Max. conveyor speed: 50 m/min (164 ft/min)
- Produces gap of approximately one product length

Vertical Blade

Part Number: 208169

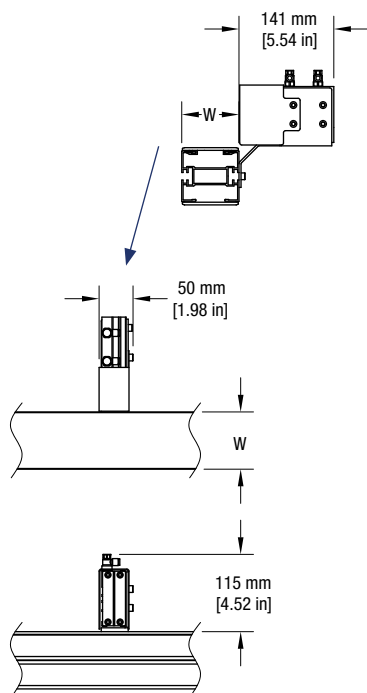

Horizontal Squeeze

Part Number: 208161

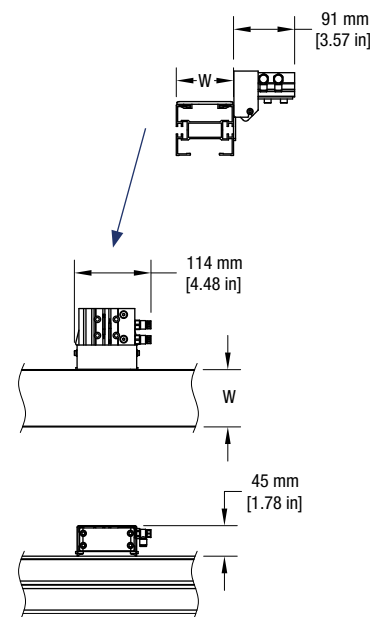

208162



Puck/Package Divert Module

- Pneumatic one-to-two lane diverter
- Compatible with round or rectangular packages or pucks
- Product can run back to back or paced for individual product divert
- UHMW divert arms for non-marking divert surface
- Includes flow controls with push-in air line connection
- Requires photo sensors, pneumatic solenoid valves, wiring and programming
- Rate depends on product size and desired flow. Contact factory for details.

Features

- Available on FlexMove Aluminium Conveyors, FS (65 mm), FM (85 mm), FC (105 mm), FL (150 mm), FU (180 mm) and FV (260 mm)
- Product must be able to stand unsupported
- Min. single product weight: 0.2 kg (0.45 lbs)
- Max. single product weight: 5 kg (11 lbs)
- Max. product height: 150 mm (5.9 in)
- Max. product width: chain width (example: FM 85 mm)

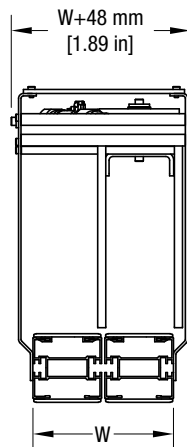
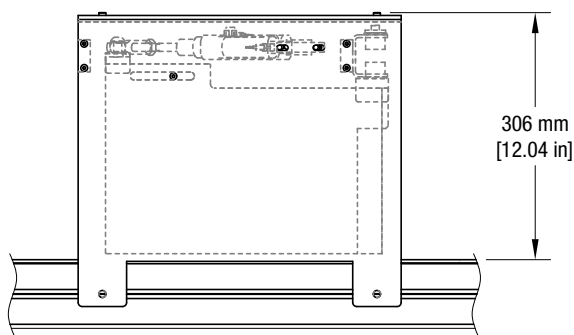
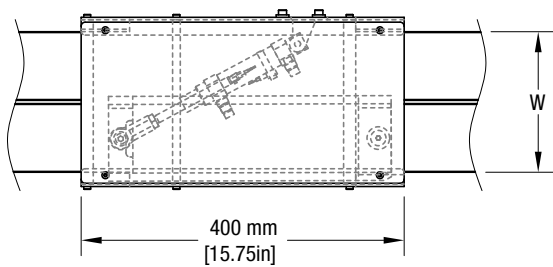

Part Number: 208162 for FM Series. Contact factory for other sizes.

Product dimensions shown for FM Series conveyors. Contact factory for other conveyor series.

Clamping Module

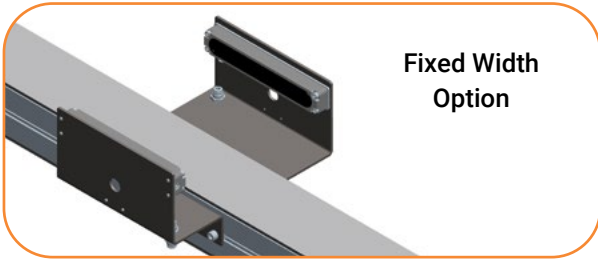

Fixed Width Option



Adjustable Width Option

Clamping Module

- Pneumatic clamping actuator, mounted on both sides of the conveyor, holds back and paces product
- Ability to pace products back to back
- Ideal for totes, boxes, bottles and square, round, and rectangular containers
- Product must be able to withstand some back pressure and squeezing force
- Requires photo sensors, pneumatic solenoid valves, wiring, and programming
- Rate depends on product size. Contact factory for details

Fixed Width Option

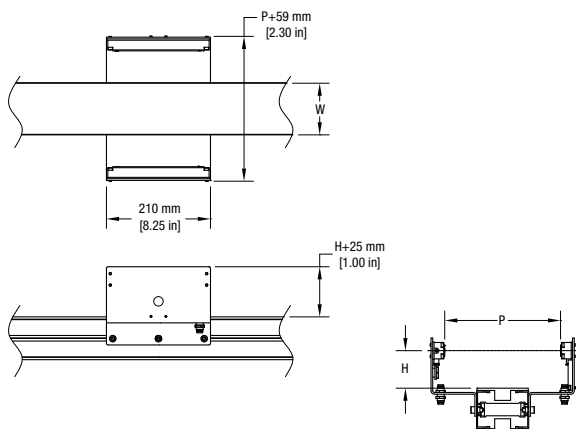

Features

- Available on FlexMove Aluminum Conveyors, FS (65 mm), FM (85 mm), FC (105 mm), FL (150 mm), FU (180 mm), and FV (260 mm)
- Max. single product weight: 2.3 Kg (5 lbs.)
- Max. product accumulation weight: 13.6 Kg (30 lbs.)
- Specify product width at time of ordering
- Specify centerline of clamping actuator above conveyor chain at time of ordering
- Max. conveyor speed: 50 m/min (164 ft/min)
- Produces gap of approximately one product length
- Includes mounting for photo sensor with 18 mm barrel

Adjustable Width Option

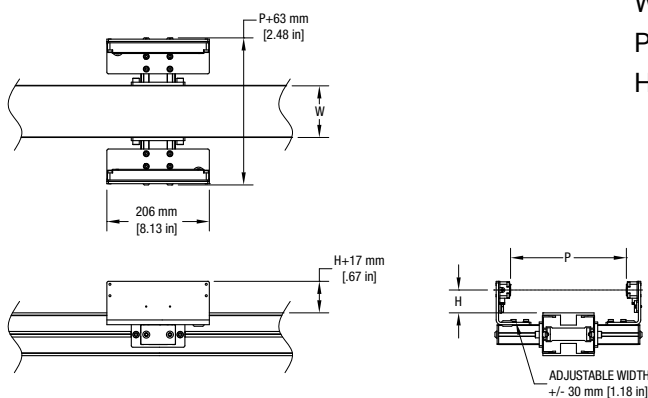

Specify at time of order:

W = conveyor width

P = product width

H = centerline of clamping actuator above conveyor chain

PUS-xx*

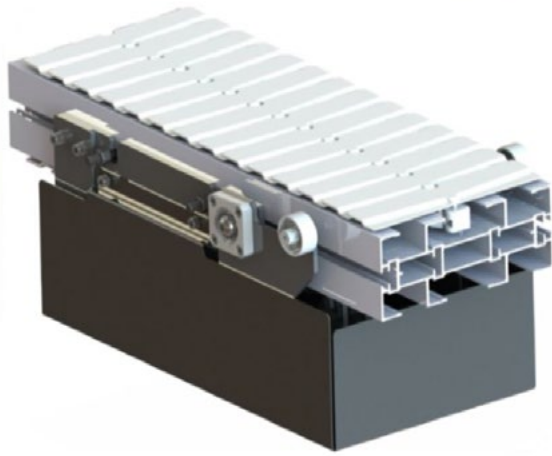

Pop-up Stop Module

- The wide pop-up stopper unit are developed to stop product movement which is wider than conveyor width.

Features

- Supported accumulation load: Up to 60kg.
- Maximum conveyor speed: up to 40m/min.
- Available for conveyor width: 45mm, 65mm, 85mm, 105mm, 150mm, 180mm & 260mm.
- Best work with FlexMove plain chain.
- Using pneumatic system.
- Can be used as product spacer.
- Can be operate without sensor.
- Low maintenance.

Specification

- Ø6mm tubing speed controller
- Operating air pressure range: 0.5~0.6MPa
- Air consumption: 0.01m³ per minute

(Calculation based on tubing length of 1.5m & Number of cycles of 180 times per hour)

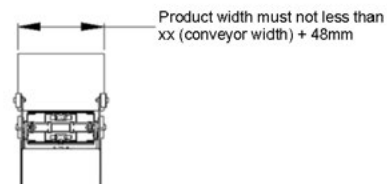
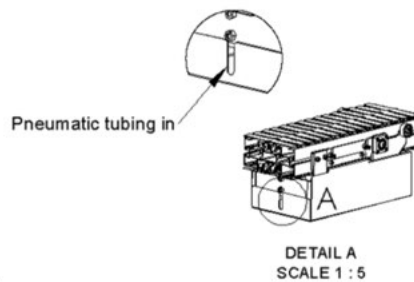
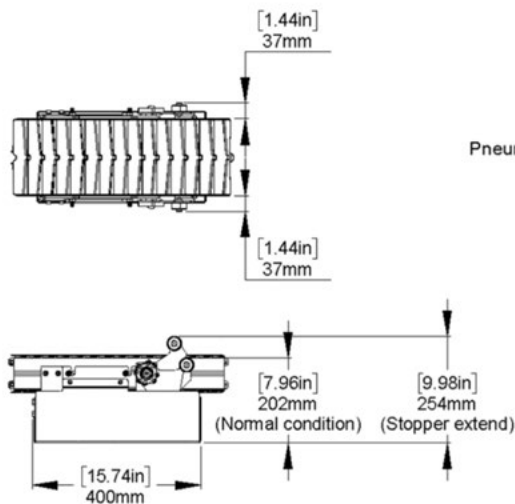
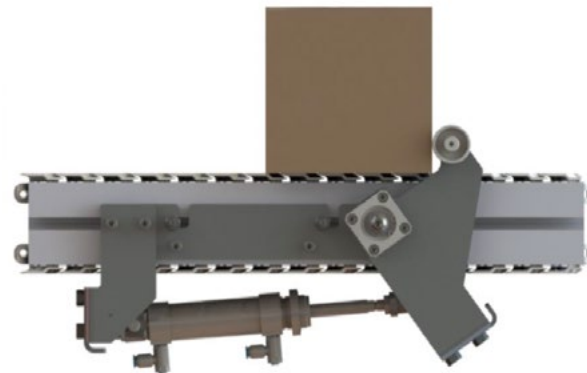

*Where xx = conveyor series (limit to FK, FS, FM, FC, FL, FU & FV)

Note: Solenoid valve optional.

Helical Plain Bend Conveyors



Helical Plain Bend Conveyors

- Reduces conveyor footprint saving valuable floor space
- Allows incline or decline through corners and straights
- Patented side roller chain reduces corner friction
- Provides capability for product buffering in corners
- Ideal for incline or decline in tight spaces



Patented Chain Design

Features

- Available on FlexMove Aluminum Conveyors: FS (65 mm), FM (85 mm), FC (105 mm), FL (150 mm), FU (180 mm) and FV (260 mm)
- Minimum 500 mm radius helical bend corner
- Corner Angles: 45, 90, 135, 180, 225, 270 and 360 degrees
- Incline and decline angles up to 12 degrees
 - Plain chain is capable of incline / decline angles up to 7 degrees
 - Friction top chain is recommended for angles of 7 to 12 degrees

Chain Types

- (2) Conveyor Chain types for maximum capability; Bearing Chain and Non-Bearing Chain

	Bearing Chain	Non-Bearing Chain
Conveyor Widths	85,180, 260 mm	65, 85, 105, 150, 180 and 260 mm
Maximum curves	Up to 4 curves	Up to 2 curves
Maximum angle	A total of 720 degrees	A total of 360 degrees
Maximum length	21.3 m (70 ft)	12.2 m (40 ft)
Maximum speed	Up to 55/min (180 ft/min)	Up to 55 m/min (180 ft/min)
Load Capacity	136 kg (300 lbs)	136 kg (300 lbs)

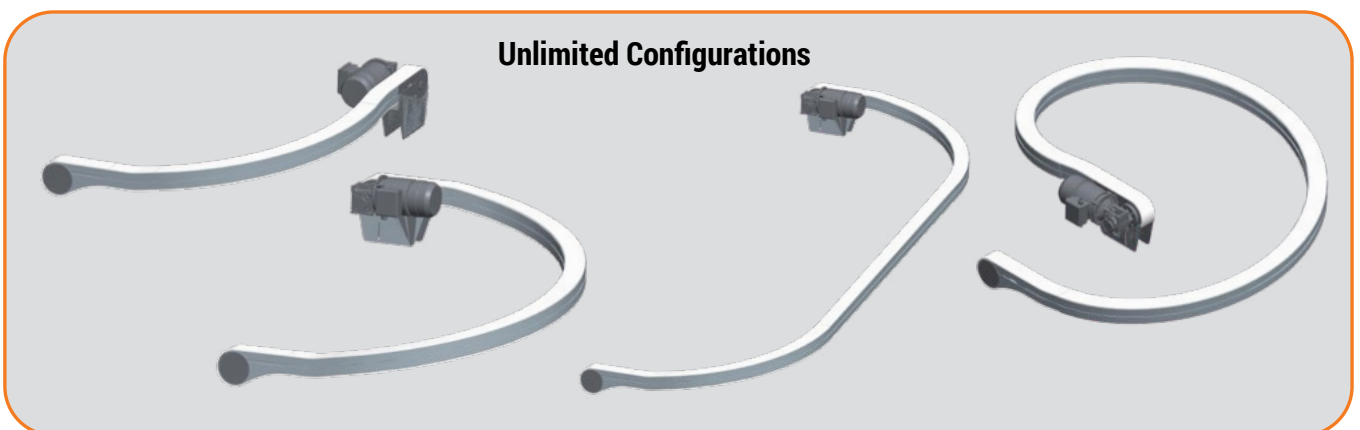

Helical Plain Bend Conveyors

Curve Layout Options:

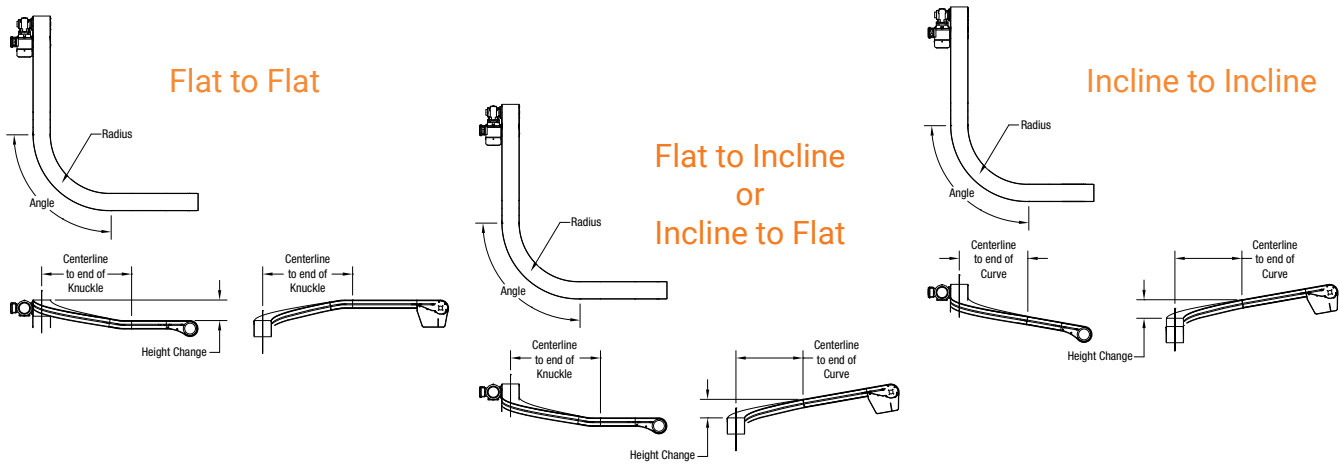

Dimensions

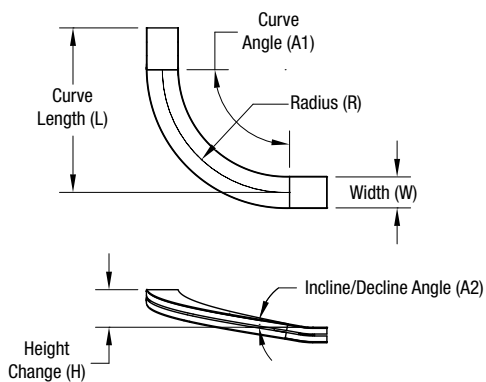

W* = 65, 85, 105, 150, 180, 260

R = 500, 700, 1000 mm

A1 = 45 to 360 degrees

A2 = 3 to 12 degrees

H = Configuration dependent, contact factory

L = Configuration dependent, contact factory

* Bearing chain in 85, 180, and 260 mm widths only

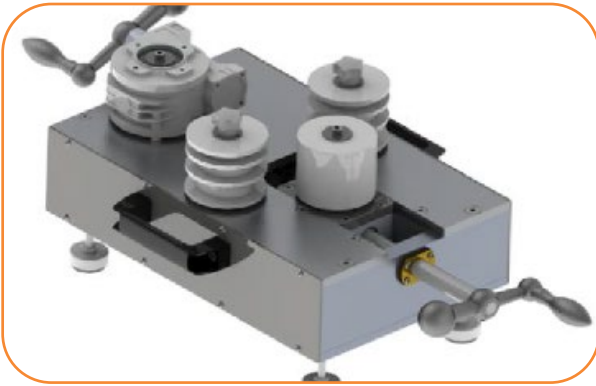

Manual Side Guide Bending Unit

Introducing the go-to companion for on-site installation and modification tasks – our Manual Side Guide Bending Unit. Engineered for the convenience of professionals on the move, this compact tool is designed to make your bending tasks easier and more efficient during on-site projects.

Features

- **Portability:** A compact and lightweight design ensures effortless transport to any worksite, saving time and effort.
- **On-Site Flexibility:** Tailored for on-site side guide installation and modification tasks, eliminating the need for costly off-site bending.
- **Approximate Angle Bending:** Designed for quick and convenient angle without the need for precision tools.
- **User-Friendly Operation:** Intuitive controls and ergonomic design make bending rail angles a breeze for all skill levels.
- **Time-Efficient:** Reduces downtime during installation and maintenance, increasing overall project efficiency.

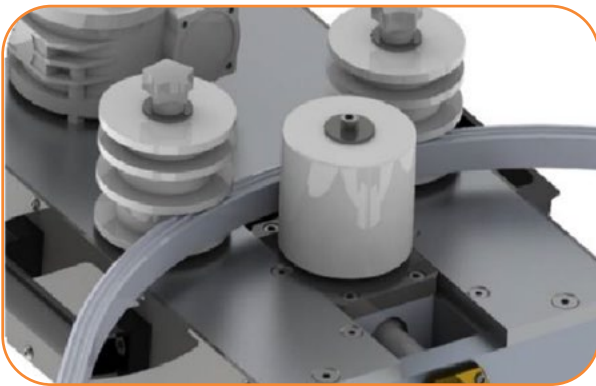

Specifications & Dimension

- **Operating Mechanism:** Manual hand crank
- **Sizes:** 256 mm x 690 mm x 254 mm (W)x(L)x(H)
- **Weight:** 28kg **Material Compatibility:** FGRR-10x20 and FGRR-15x20

FAHBS-40

Horizontal beam support bracket - Aluminum

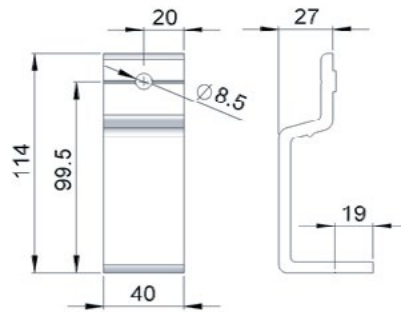
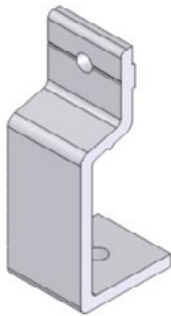
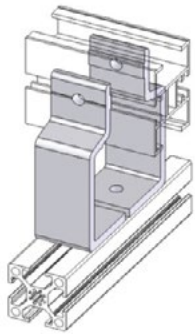

UOM: pc

For 40 mm horizontal crossing support beam

Mounting: FATB-20(1),
FALN-M8(1), FAHB-M8 x16(1),
FASN-M8(1), FAFW-M8 (2)

FAHBS-60

Horizontal beam support bracket - Aluminum

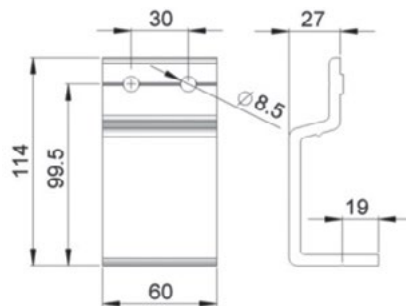
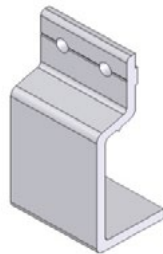
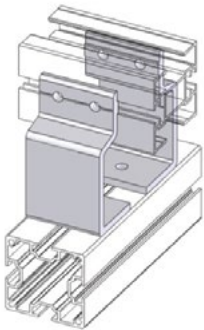

UOM: pc

For 64 mm horizontal crossing support beam

Mounting: FATB-20(2),
FALN-M8(2), FAHB-M8 x16(1),
FASN-M8(1), FAFW-M8 (3)

FAHBS-80

Horizontal beam support bracket - Aluminum

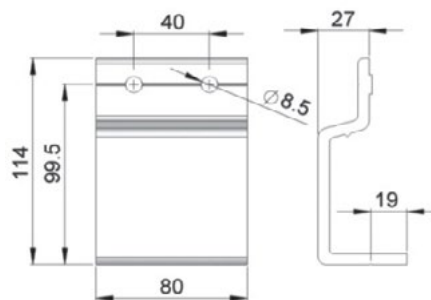
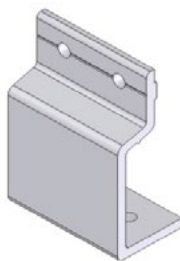
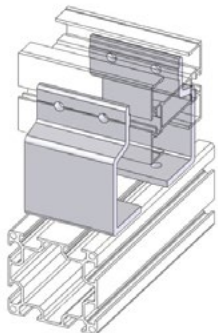

UOM: pc

For 80 mm horizontal crossing support beam

Mounting: FATB-20(2), FALN-M8(2),
FAHB-M8 x16(2), FASN-M8(2),
FAFW-M8 (4)

FAVBS-60K

Vertical beam support bracket - Aluminum

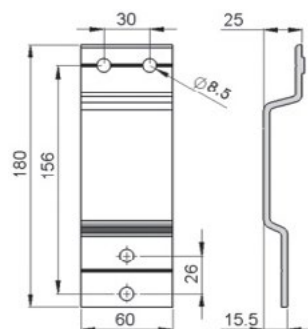
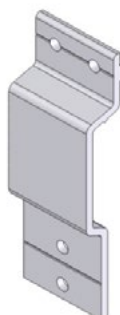
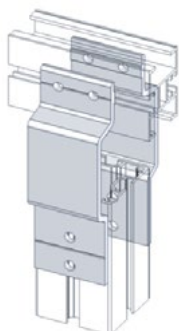

UOM: pc

For FK conveyor with 64 mm vertical support beam

Mounting: FATB-20(2),
FALN-M8(2), FAHB-M8 x16(2),
FASN-M8(2), FAFW-M8 (4)

FAVBS-60S

Vertical beam support bracket - Aluminum

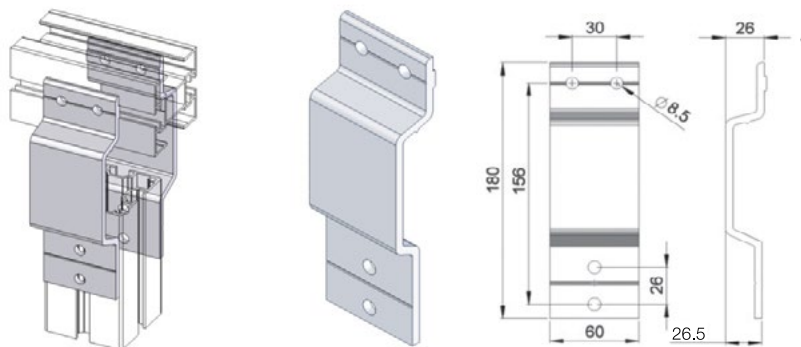

UOM: pc
For FS conveyor with 64 mm vertical beam support

Mounting: FATB-20(2),
FALN-M8(2), FAHB-M8 x16(2),
FASN-M8(2), FAFW-M8 (4)

FAVBS-80S

Vertical beam support bracket - Aluminum

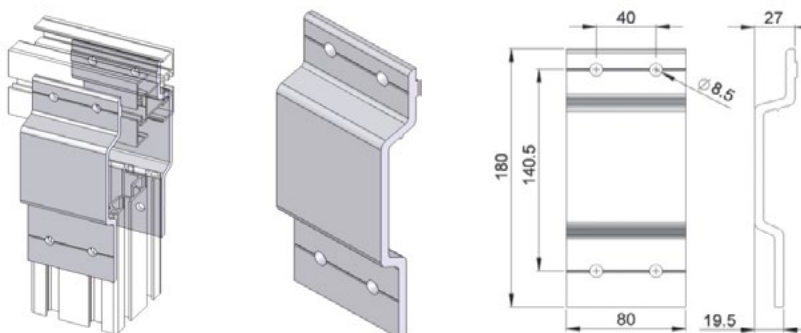

UOM: pc
For FS conveyor with 80 mm vertical beam support

Mounting: FATB-20(2),
FALN-M8(2), FAHB-M8 x16(2),
FASN-M8(2), FAFW-M8 (4)

FAVBS-60M

Vertical beam support bracket - Aluminum

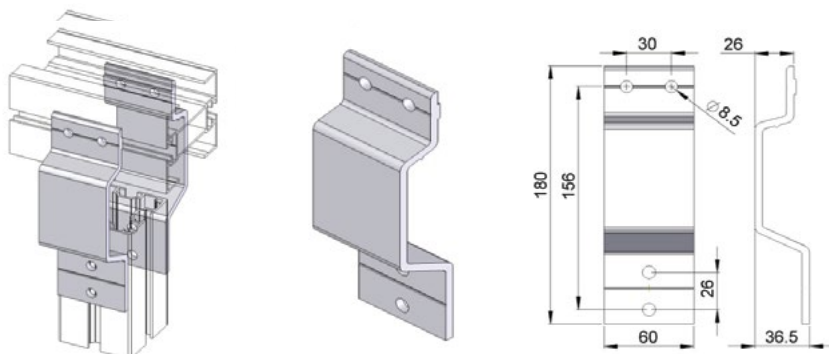

UOM: pc
For FM conveyor with 64 mm vertical support beam

Mounting: FATB-20(2), FALN-M8(2),
FAHB-M8 x16(2), FASN-M8(2),
FAFW-M8 (4)

FAVBS-80M

Vertical beam support bracket - Aluminum

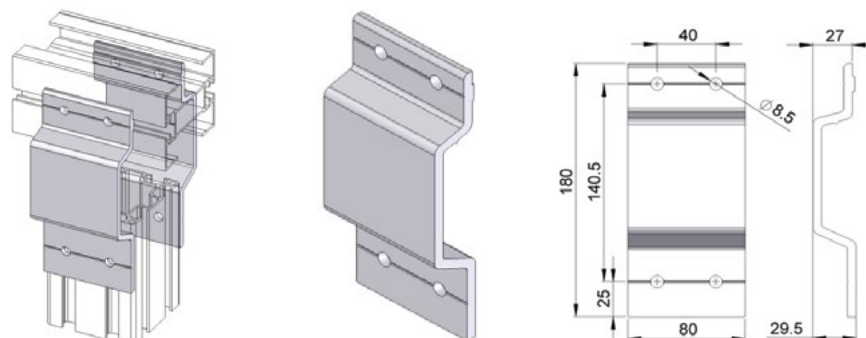

UOM: pc
For FM conveyor with 80 mm vertical beam support

Mounting: FATB-20(2),
FALN-M8(2), FAHB-M8 x16(2),
FASN-M8(2), FAFW-M8 (4)

FAVBS-60C

Vertical beam support bracket - Aluminum

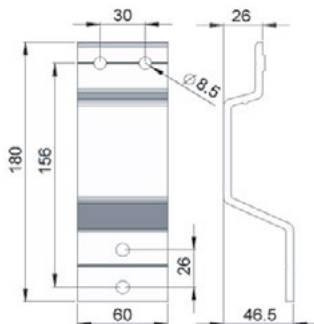
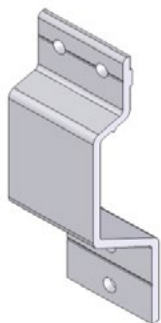
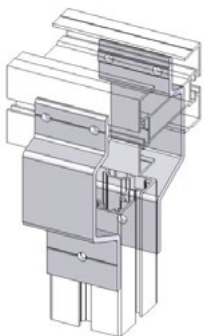

UOM: pc

For FC conveyor with 64 mm vertical beam support

Mounting: FATB-20(2),
FALN-M8(2), FAHB-M8 x16(2),
FASN-M8(2), FAFW-M8 (4)

FAVBS-80C

Vertical beam support bracket - Aluminum

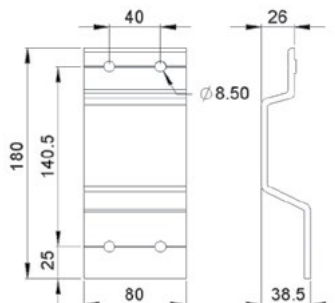
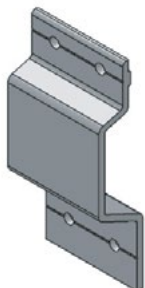
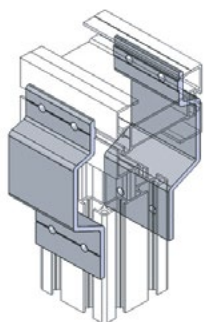

UOM: pc

For FC conveyor with 80 mm vertical beam support

Mounting: FATB-20(2),
FALN-M8(2), FAHB-M8 x16(2),
FASN-M8(2), FAFW-M8 (4)

FAVBS-80L

Vertical beam support bracket - Aluminum

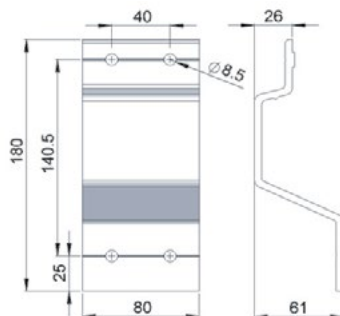
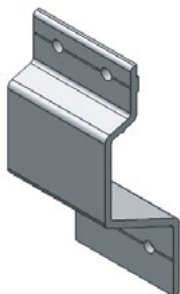
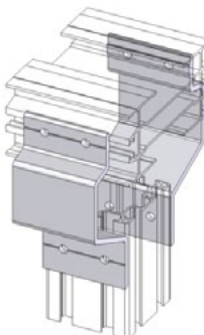

UOM: pc

For FL conveyor with 80 mm vertical beam support

Mounting: FATB-20(2), FALN-M8(2),
FAHB-M8 x16(2), FASN-M8(2),
FAFW-M8 (4)

FAVBS-80U

Vertical beam support bracket

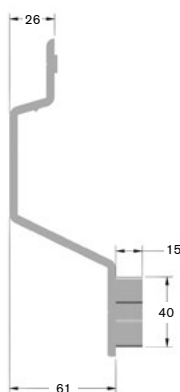
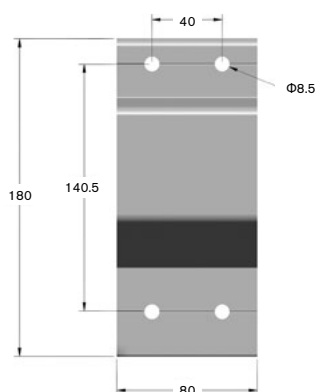

UOM: pc

For FU conveyor with 80 mm vertical beam support

Mounting: FATB-20(2), FALN-M8(2),
FAFW-M8 (2)

FAVBS-80V

Vertical beam support bracket

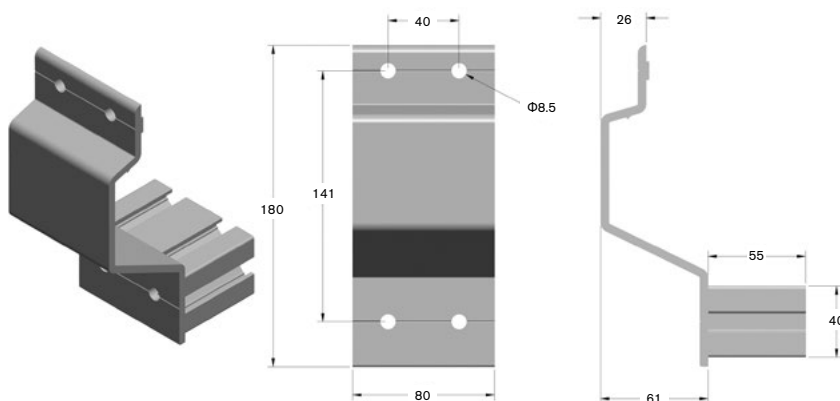

UOM: pc
For FV conveyor with 80 mm vertical beam support

Mounting: FATB-20(2), FALN-M8(2), FAFW-M8 (2)

FAVBS-60KV

Vertical beam support bracket with slot - Aluminum

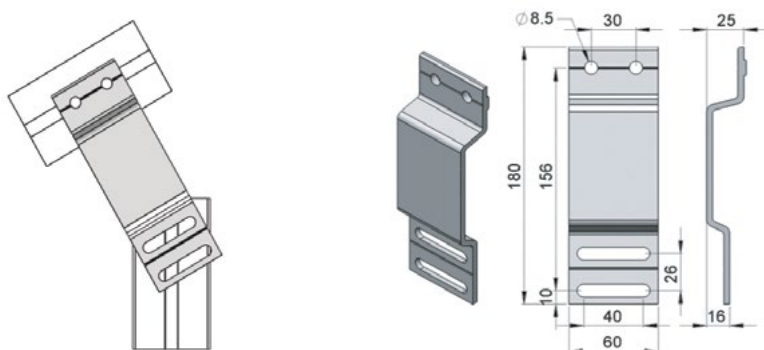

UOM: pc
For FK conveyor with 64 mm vertical support beam

Mounting: FATB-20(2), FALN-M8(2), FAHB-M8 x16(2), FASN-M8(2), FAFW-M8 (4)

FAVBS-60SV

Vertical beam support bracket with slot - Aluminum

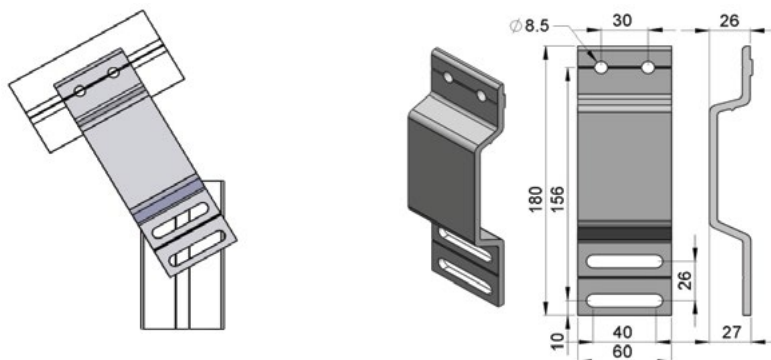

UOM: pc
For FS conveyor with 64 mm vertical beam support

Mounting: FATB-20(2), FALN-M8(2), FAHB-M8 x16(2), FASN-M8(2), FAFW-M8 (4)

FAVBS-80SV

Vertical beam support bracket with slot - Aluminum

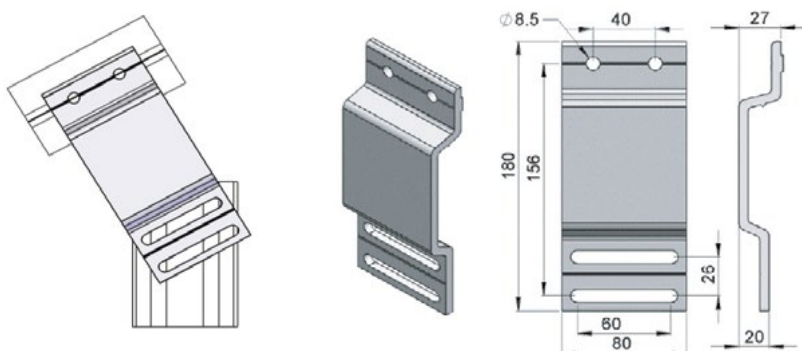

UOM: pc
For FS conveyor with 80 mm vertical beam support

Mounting: FATB-20(2), FALN-M8(2), FAHB-M8 x16(2), FASN-M8(2), FAFW-M8 (4)

FAVBS-60MV

Vertical beam support bracket with slot - Aluminum

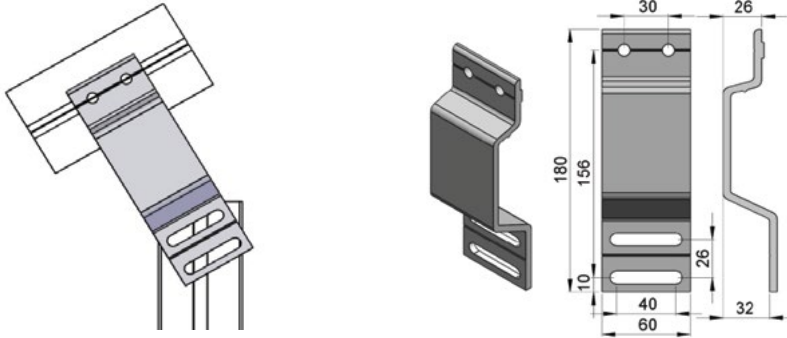

UOM: pc

For FM conveyor with 64 mm vertical support beam

Mounting: FATB-20(2), FALN-M8(2), FAHB-M8 x16(2), FASN-M8(2), FAFW-M8 (4)

FAVBS-80MV

Vertical beam support bracket with slot - Aluminum

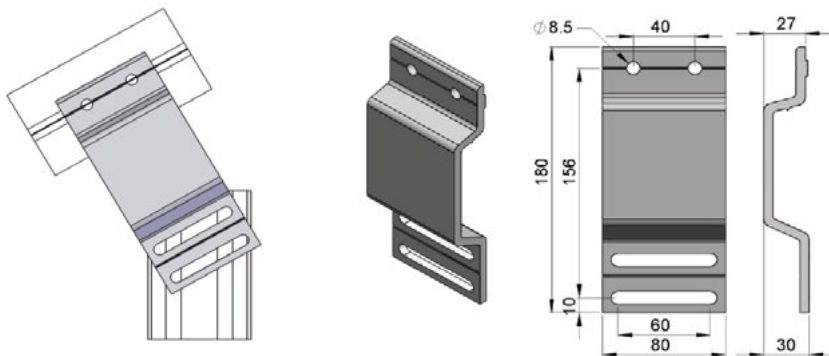

UOM: pc

For FM conveyor with 80 mm vertical beam support

Mounting: FATB-20(2), FALN-M8(2), FAHB-M8 x16(2), FASN-M8(2), FAFW-M8 (4)

FAVBS-60CV

Vertical beam support bracket with slot - Aluminum

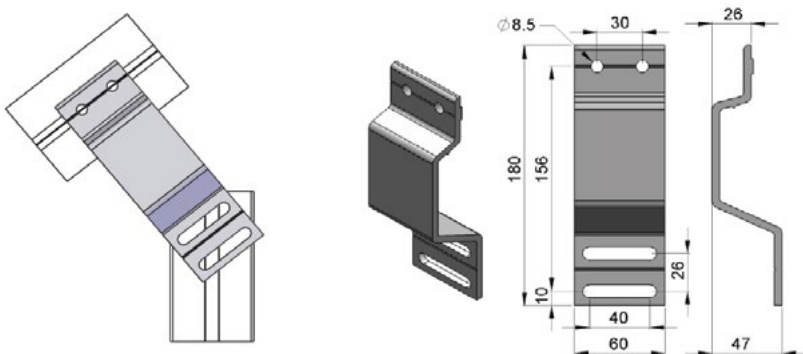

UOM: pc

For FC conveyor with 64 mm vertical beam support

Mounting: FATB-20(2), FALN-M8(2), FAHB-M8 x16(2), FASN-M8(2), FAFW-M8 (4)

FAVBS-80LV

Vertical beam support bracket - Aluminum

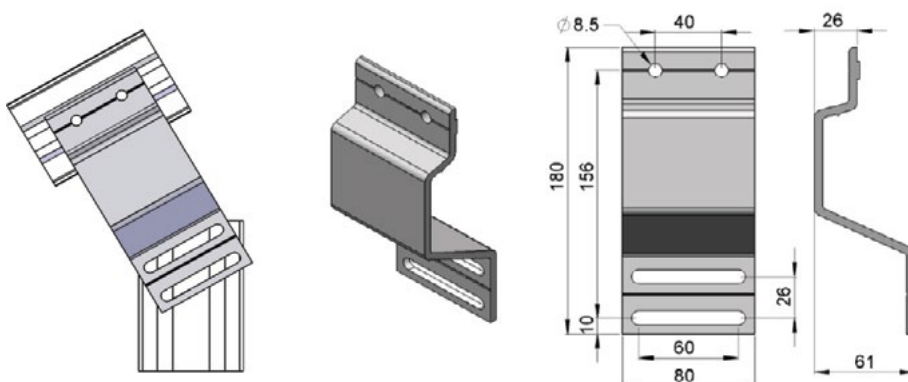

UOM: pc

For FL conveyor with 80 mm vertical beam support

Mounting: FATB-20(2), FALN-M8(2), FAHB-M8 x16(2), FASN-M8(2), FAFW-M8 (4)

FAVBS-80UV

Vertical beam support bracket

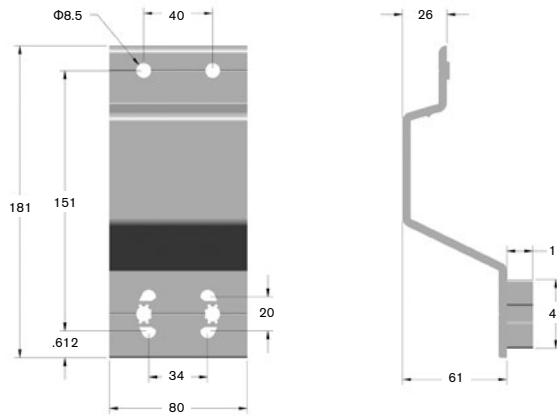
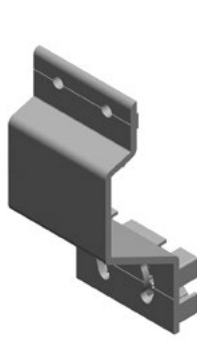

UOM: pc
For FU conveyor with 80 mm vertical support beam

Mounting: FATB-20(2), FALN-M8(2), FAFW-M8 (2)

FAVBS-80VV

Vertical beam support bracket

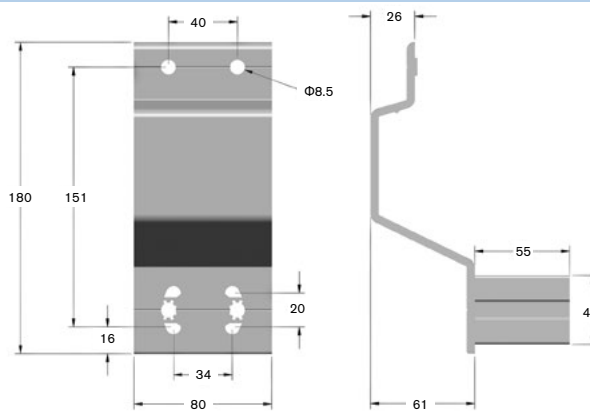
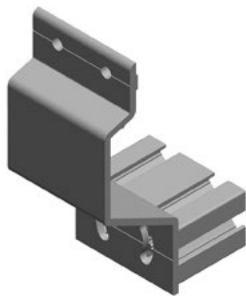

UOM: pc
For FU conveyor with 80 mm vertical beam support

Mounting: FATB-20(2), FALN-M8(2), FAFW-M8 (2)

FAHBS-40x135

Horizontal beam support bracket - Aluminum

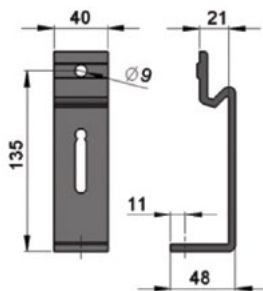

UOM: pc
For 40 mm horizontal crossing support beam

FAHBS-62x135

Horizontal beam support bracket - Aluminum

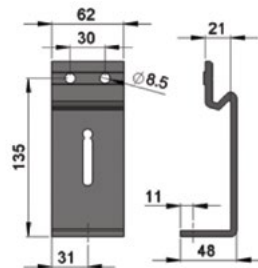

UOM: pc
For 64mm horizontal crossing support beam

FAHBS-80x135

Horizontal beam support bracket - Aluminum

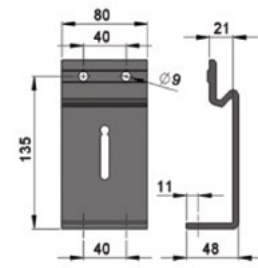

UOM: pc
For 80 mm horizontal crossing support beam

FADBS-WWXV

Drive End Support Bracket

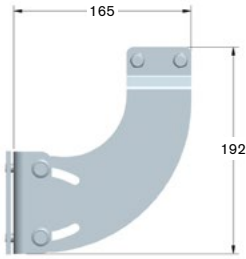

UOM: pc

For support of direct drive end to vertical beam support

Mounting: All provided

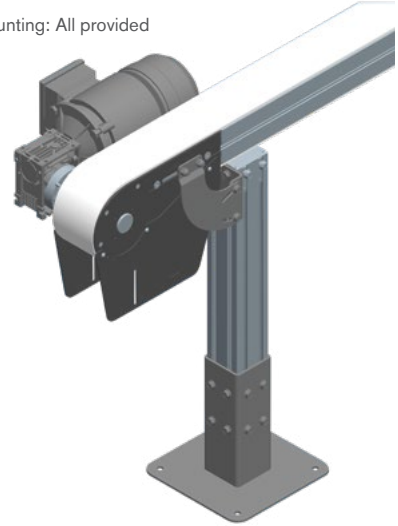

Part Number	Beam	Conveyor	Adjustable	
FADBS	60 = 64 x 64	WW	X	
		K = 45 mm		
		S = 65 mm		
	80 = 80 x 80	M = 85 mm		V
		C = 105 mm		
		L = 150 mm		
		U = 180 mm		
	V = 260 mm			

FAAL-64

Alpine beam support bracket - Aluminum

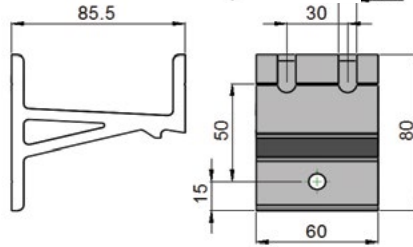
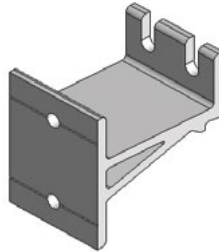
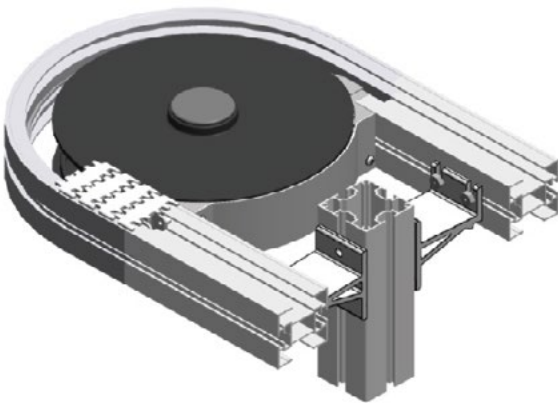

UOM: pc

For support of 180° wheel bend with 64 mm vertical beam support

Mounting: FAHB-M8 x16(4) , FASN-M8(4) , FAFW-M8 (4)

FAAL-80

Alpine beam support bracket - Aluminum

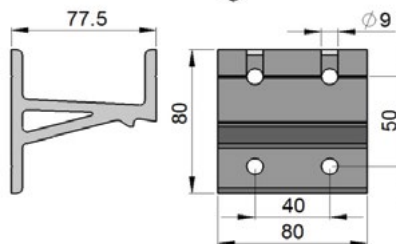
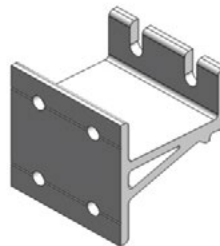
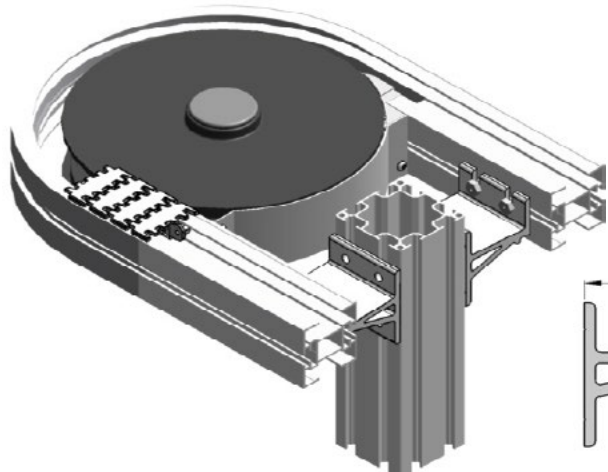

UOM: pc

For support of 180° wheel bend with 80 mm vertical beam support

Mounting: FAHB-M8 x16(6) , FASN-M8(6) , FAFW-M8 (6)

FASR-25
FASR-25U
FASR-25X
FASR-25T
FASR-25CD

HDPE slide rail - White
 UHMW-PE slide rail - White
 Special PE slide rail - Blue
 PAPE slide rail - Grey
 Conductive slide rail - Black

"Normal Application"
 "Low Friction, suitable for accumulation"
 "Lowest Friction, suitable for accumulation"
 "High abrasive and High load"
 "Static conductive"

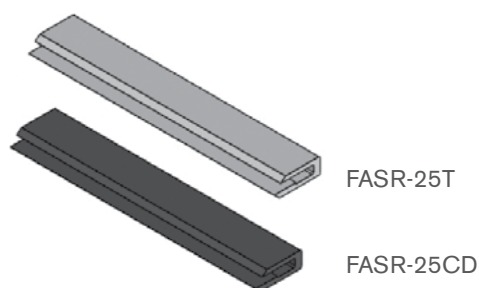
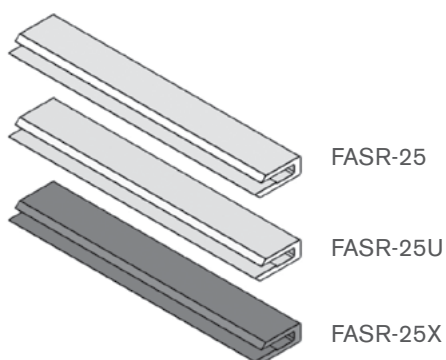
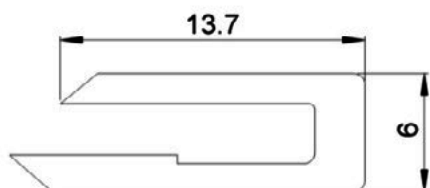

UOM: 25meter / roll

FASLR-4x6 Aluminum rivet for slide rail

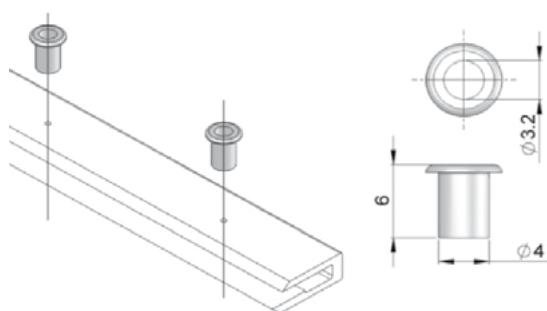

UOM: 50pcs / pk

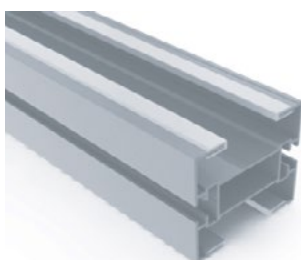

807-2694 Nylon Socket screw for slide rail

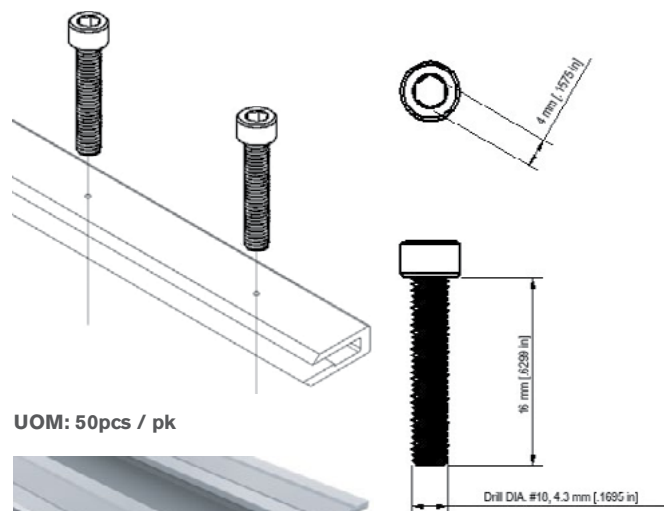

UOM: 50pcs / pk

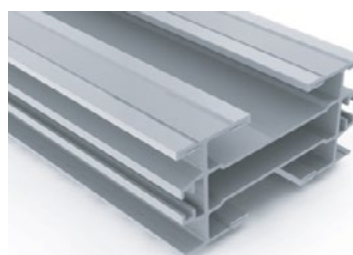

Note: 807-2694 available in North America only.

FASR-25KU

UHMW-PE slide rail

FASR-25K

HDPE slide rail

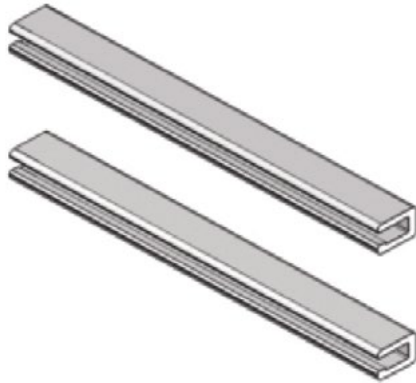

FASR-25KU

FASR-25K

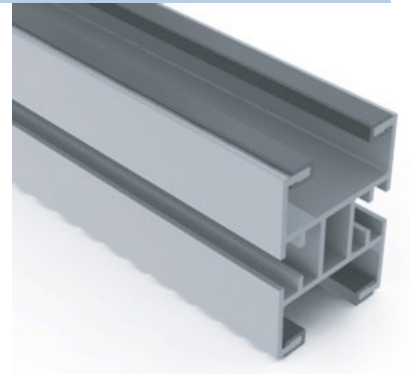
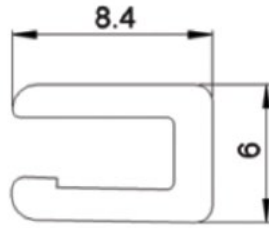

For FK Series Conveyors

UOM: 25meter / roll

807-4128

Nylon Socket screw for slide rail

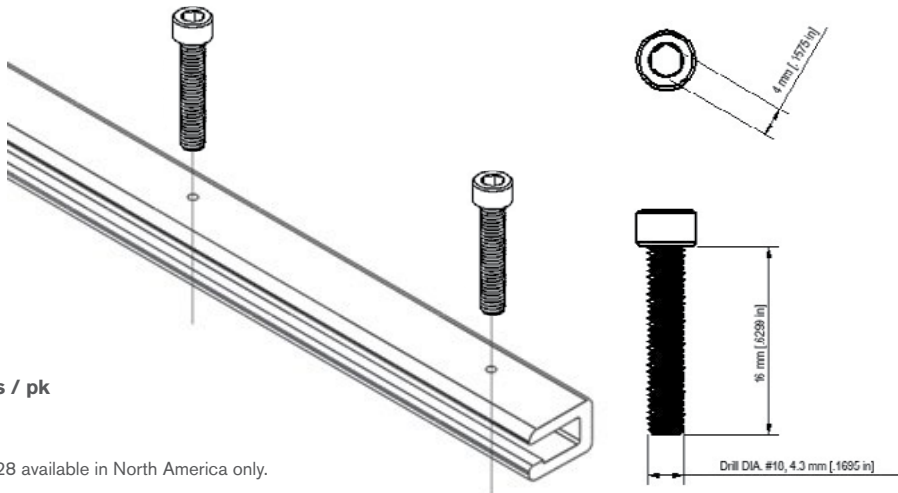

UOM: 50pcs / pk

Note: 807-4128 available in North America only.

For FK Series Conveyors

207262

Bracket Assembly, Suspended Drive

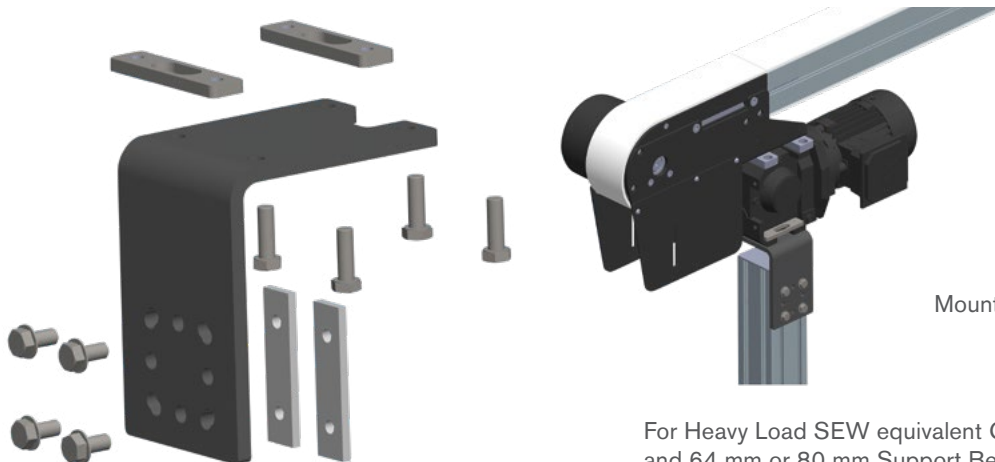

UOM: kit

Mounting: Included

For Heavy Load SEW equivalent Gearmotor and 64 mm or 80 mm Support Beams

FACS-20x140

Connecting strip – Steel, electro zinc plated

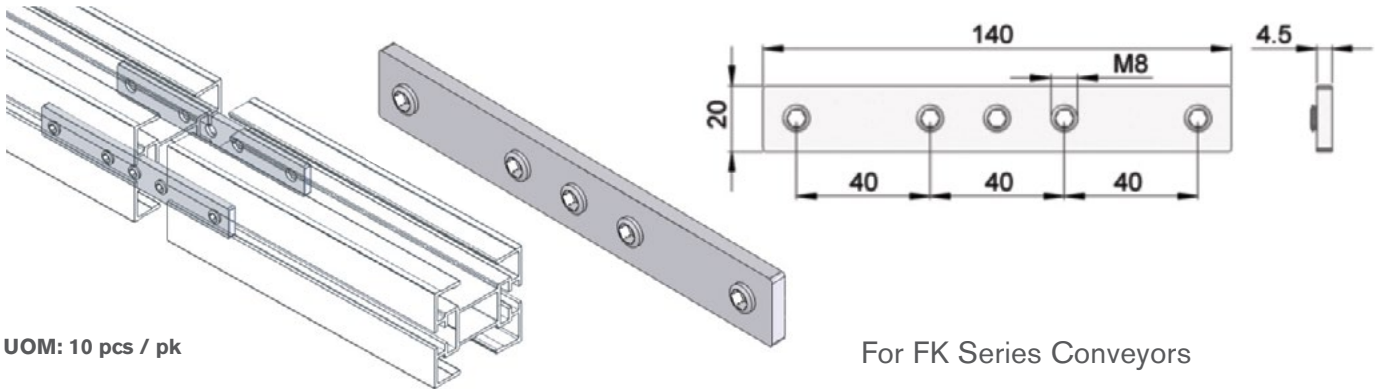

UOM: 10 pcs / pk

FACS-25x140A

Connecting strip – Steel, electro zinc plated

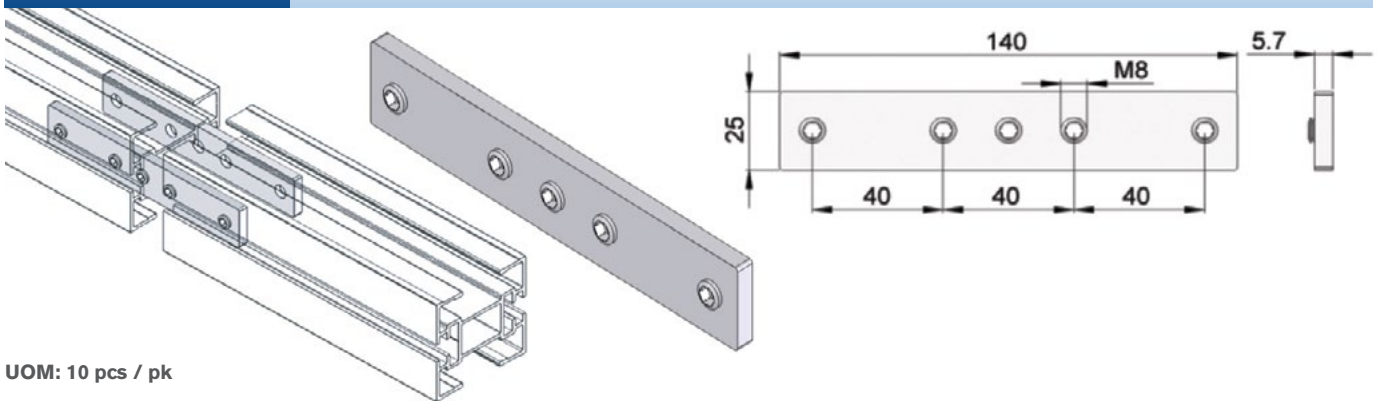

UOM: 10 pcs / pk

FASC-25

T-Slot Cover – Soft PVC (25 meter / Roll)

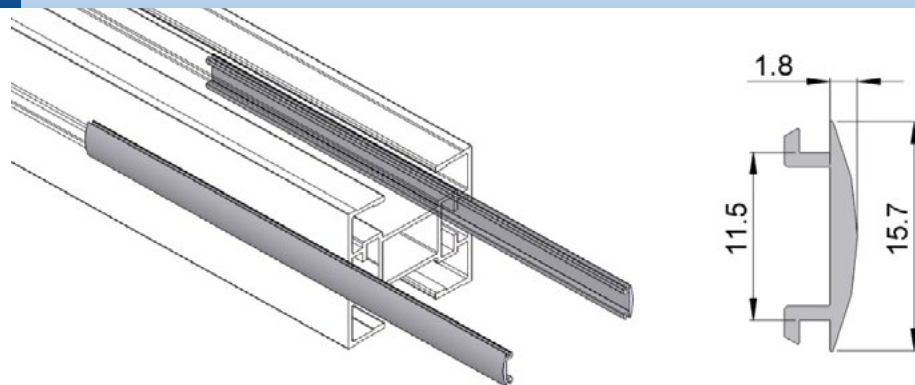

UOM: 25 meter / roll

FASN-M6

M6 Square Nut for Outer Slot – Steel, electro zinc plated

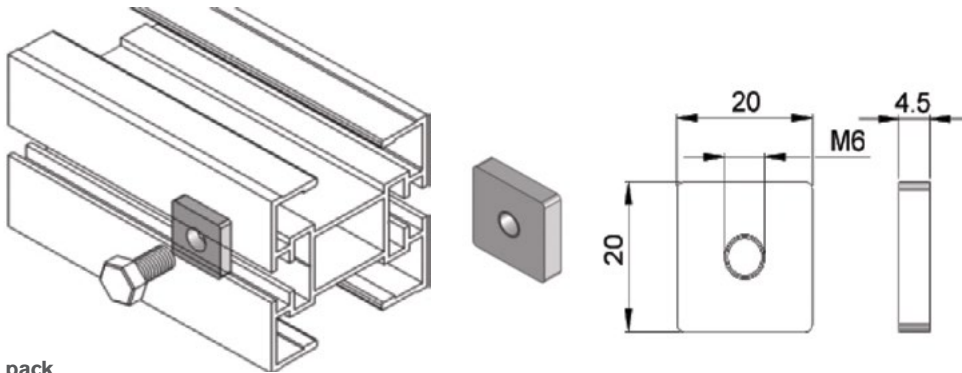

UOM: 50 pcs / pack

FASN-M8

M8 Square Nut for Inner Slot – Steel, electro zinc plated

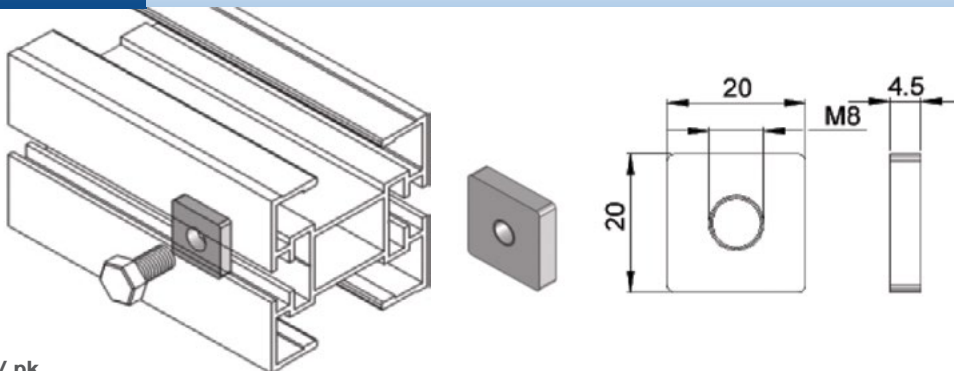

UOM: 50 pcs / pk

FATB-20

T-bolt, L = 20 – Steel, zinc plated

FATB-35

T-bolt, L = 35 – Steel, zinc plated

FATB-53

T-bolt, L = 53 – Steel, zinc plated

FATB-71

T-bolt, L = 71 – Steel, zinc plated

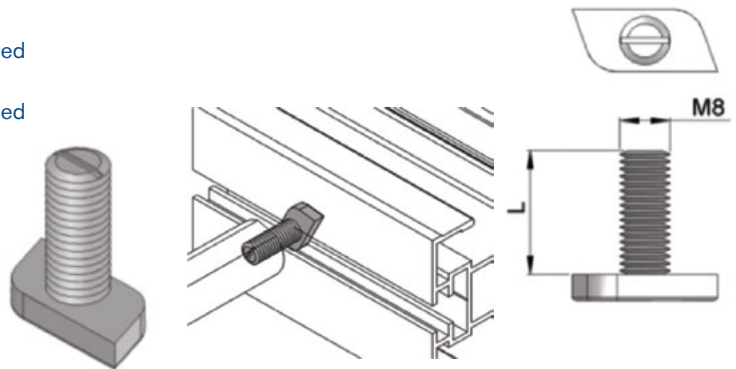

UOM: 50 pcs / pk

FASL-M8

Spring Leaf Nut M8 for 40x40, 64x64, 40x80, 80x80 Support Beam - Steel, zinc plated

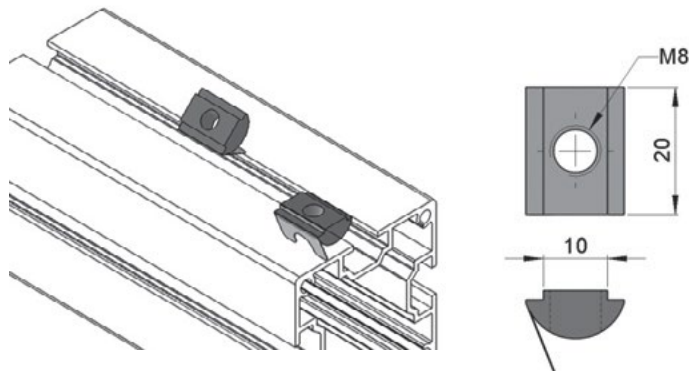

UOM: 50 pcs / pk

FAFW-M8

M8 Flat washer – Steel, zinc plated

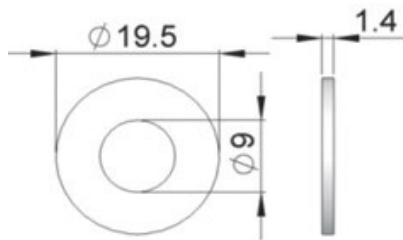

UOM: 50 pcs / pk

FALN-M8

M8 Lock Nut – Steel, zinc plated

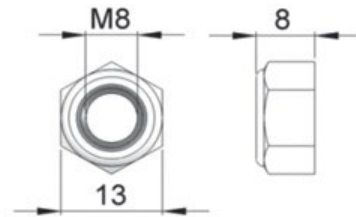

UOM: 50 pcs / pk

FAHB- M8 x 16

Hex Bolt, M8 – Steel, zinc plated

FAHB-M8 x 20

Hex bolt, L = 16 – Steel, zinc plated

Hex bolt, L = 20 – Steel, zinc plated

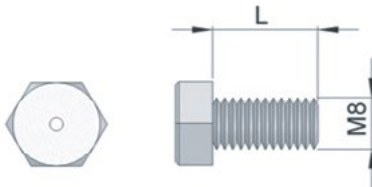

UOM: 50 pcs / pk

FAFR-35

Free roller – POM

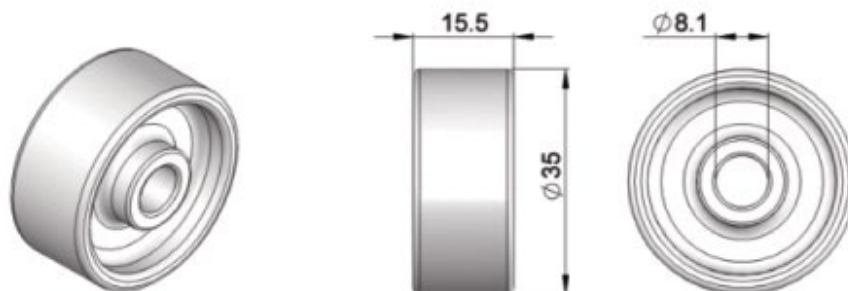

UOM: 10 pcs / pk

FAFR-18

Free roller – POM

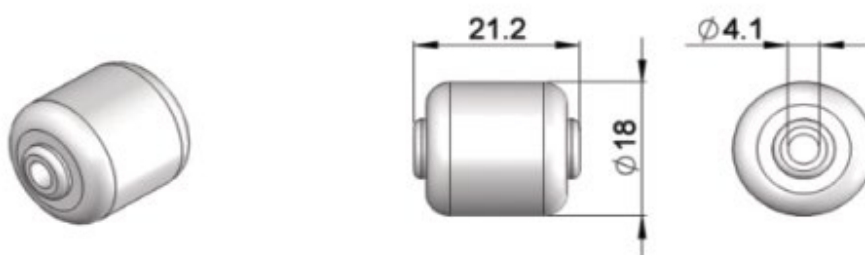

UOM: 10 pcs / pk

FAFR-11

Free roller - POM

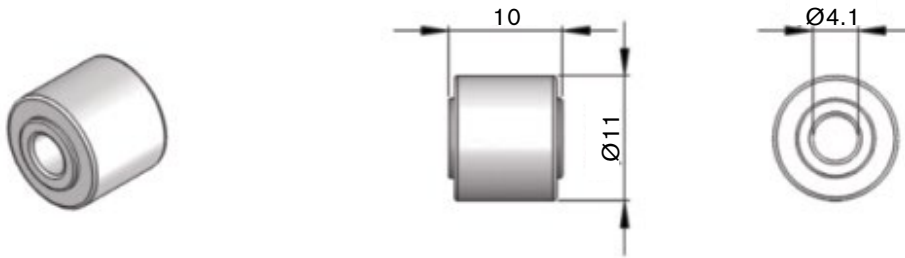

UOM: 10 pcs / pk

FASR-75x15

Sponge roller, Sponge rubber

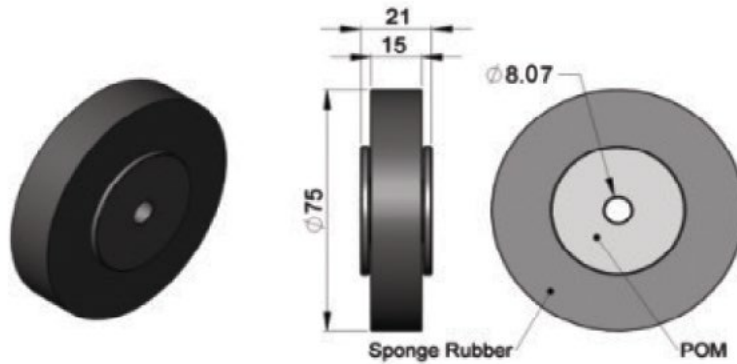

UOM: 10 pcs / pk

FASR-75x19P

PVC Roller c/w POM core & Screw

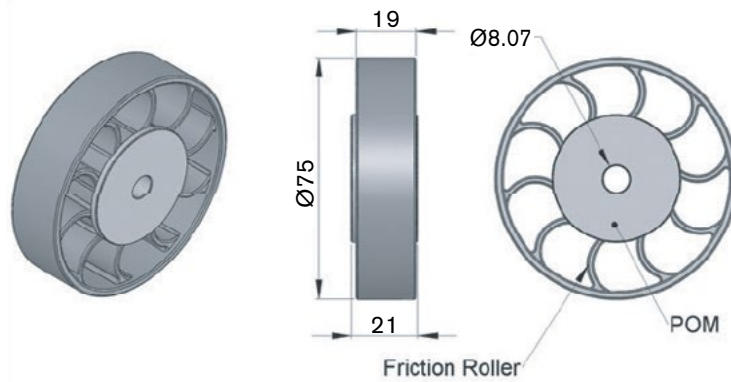

UOM: 10 pcs / pk

FAEC-DS

End cap for drive shaft - Polyamide

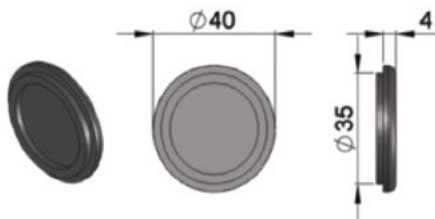

UOM: 10 pcs / pk

FAEC-WH

End cap for wheel - Polyamide

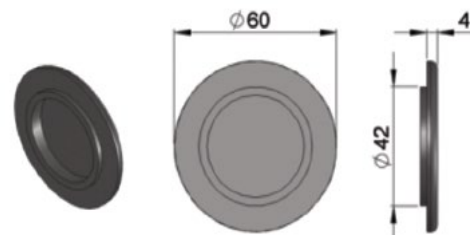

UOM: 10 pcs / pk

203395-WWW WWW = Conveyor Width: 065, 085, 105, 150

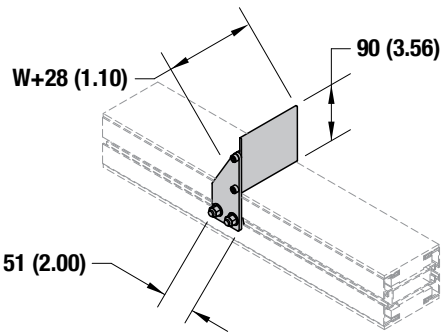

Adjustable Stop

- Product End stop at any location on conveyor rail
- For accumulating product
- Not compatible with Friction Insert Chain

Available in North America only.

203399

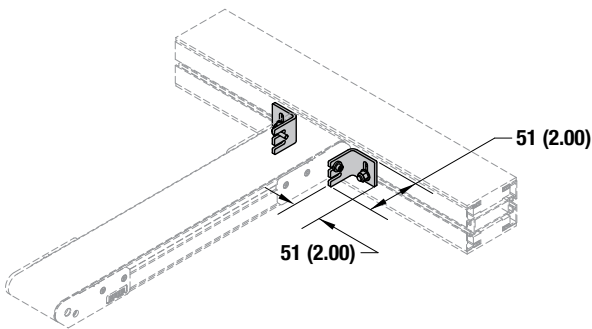

Conveyor 90° Transfer Bracket

- Provides mounting bracket and transfer plate for 90° product transfers
- Provides solid conveyor alignment for trouble free transfers
- Compatible with all widths of FlexMove conveyors

Available in North America only.

FACS-25x160 Connecting strip – Steel, electro zinc plated

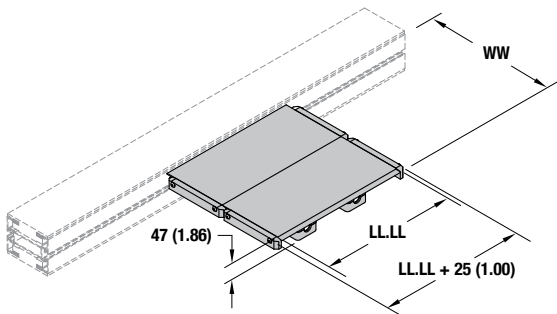

Side Tables

- Provides a 152 mm (6 in) or 305 mm (12 in) wide working surface
- Adjusts in/out and up/down for product transfer on/off conveyor belts
- Can be positioned anywhere along the conveyor
- Anodized aluminum work surface
- Max load: 6 kg/m (5 lbs/ft), use Adjustable Tie Brackets for added capacity
- Available in 305 mm (1 ft) increments from 305 mm (1 ft) to 30,175 mm (99 ft)

Available in North America only.

Side Tables			
27MSF	N	W	LLLL
			Table Length in LLLL Feet (ex. 0250 = 2.5 feet)
			Table Width: 06 = 6" 12 = 12"
			Number of Sides: 1 = one side 2 = both sides

204398

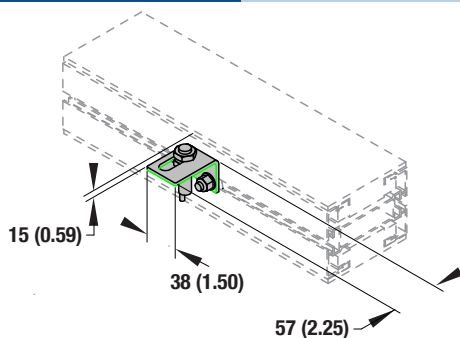

Pallet Sensor Bracket

- Provides mounting bracket for proximity sensor of pallet
- Compatible with 12 mm diameter proximity sensors
- Proximity sensor faces upward
- Adjustable, mounts along conveyor T-slot
- Top of bracket to pallet locating block: 28 mm (1.09 in)

Available in North America only.

Note: Due to the wide variety of conveyor set ups and applications, point of installation guarding is the responsibility of the end user. Note: Dimensions = mm (in)

Single Support Structure with enclosure beam
FK, FS, FM, FC

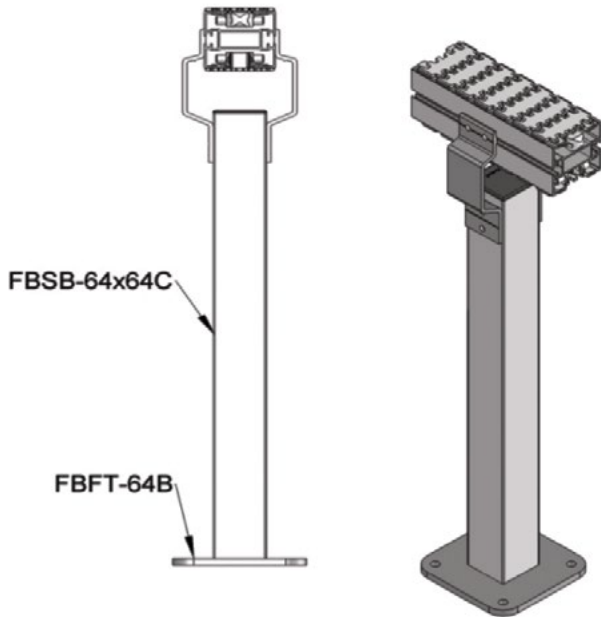

Double Lane Support Structure
FK, FS, FM, FC, FL

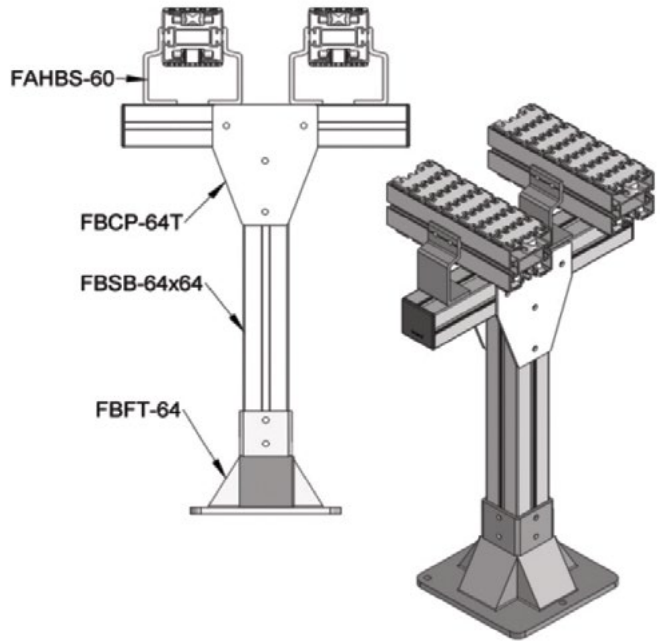

Single Support Structure
FL

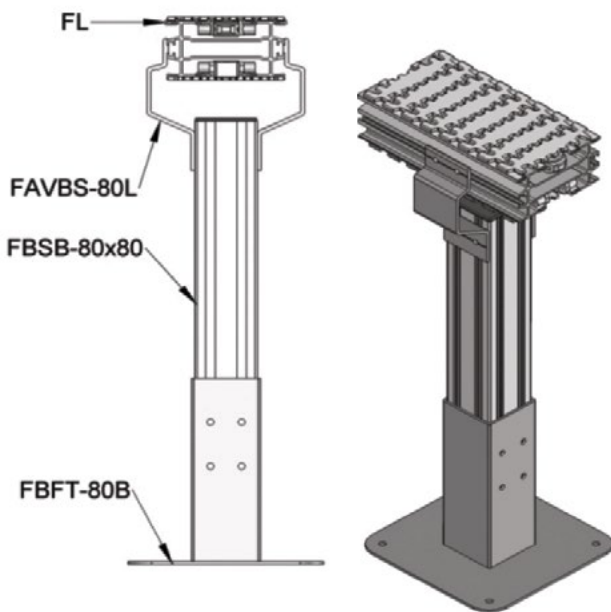

Alpine Support Structure
FK, FS, FM, FC, FL

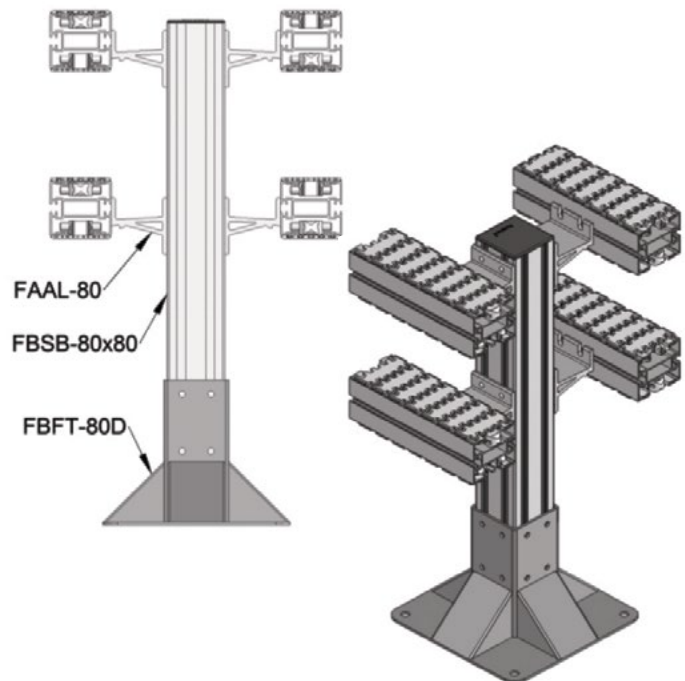

Double Support Structure **FK, FS, FM, FC**

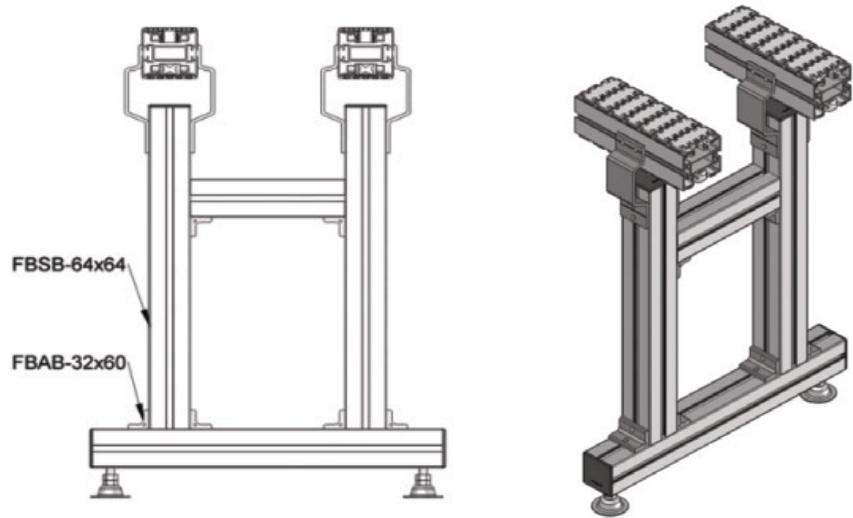

Multi Lane Support Structure **FK, FS, FM, FC, FL**

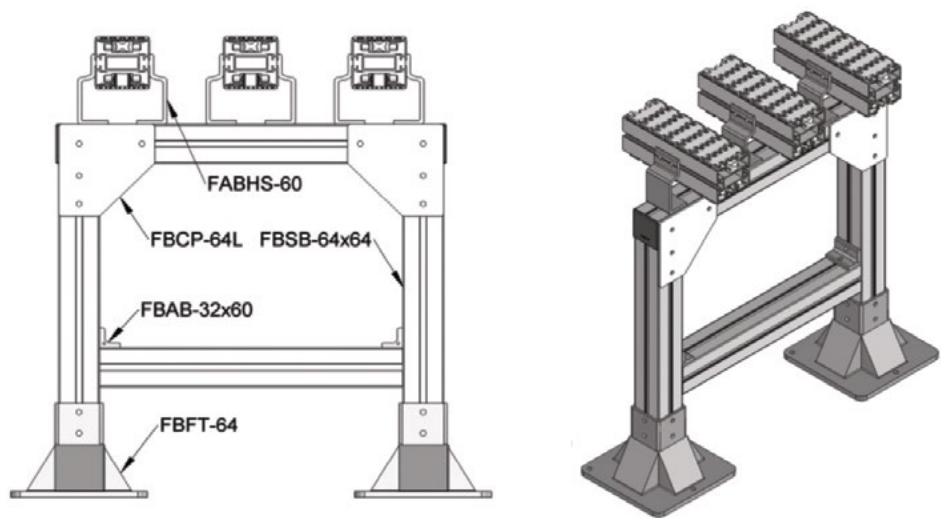

Double Support Structure **FK, FS, FM, FC**

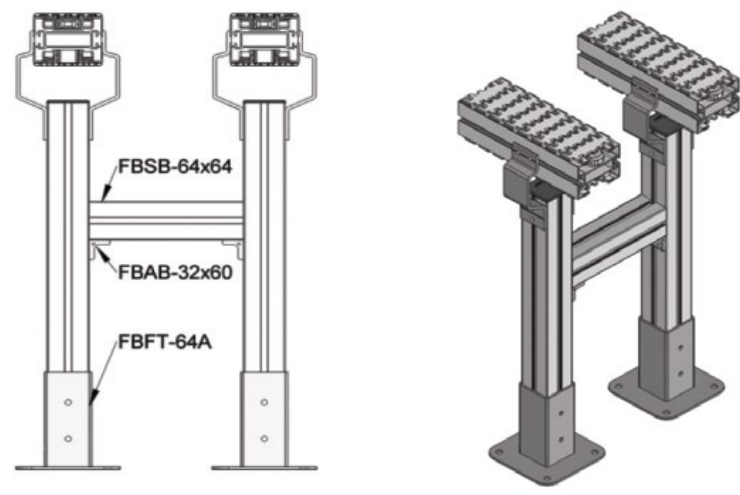

Multi Lane Double Layer Support Structure **FK, FS, FM, FC, FL**

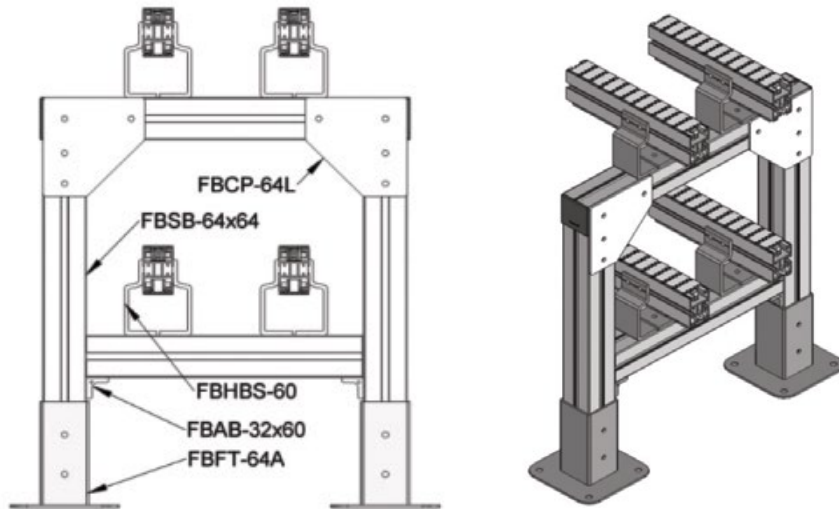

Ceiling Hanger Support Structure **FK, FS, FM, FC, FL**

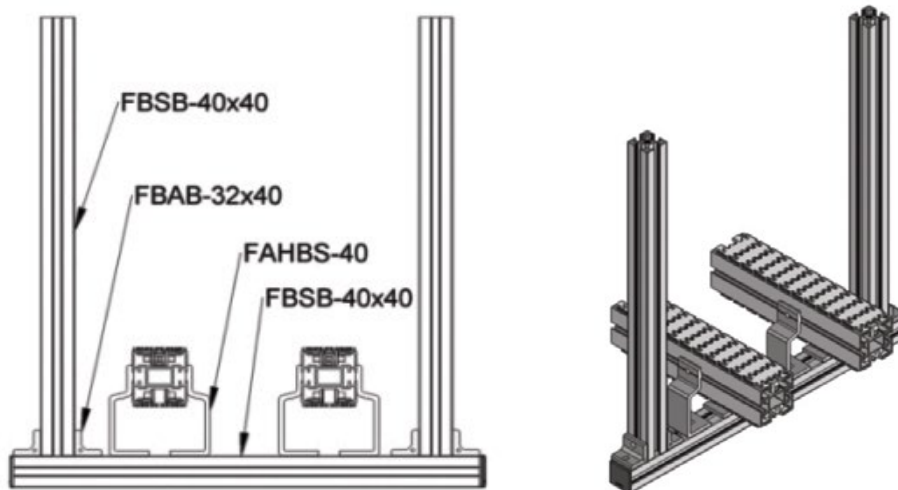

Wall Mount Support Structure **FK, FS, FM, FC**

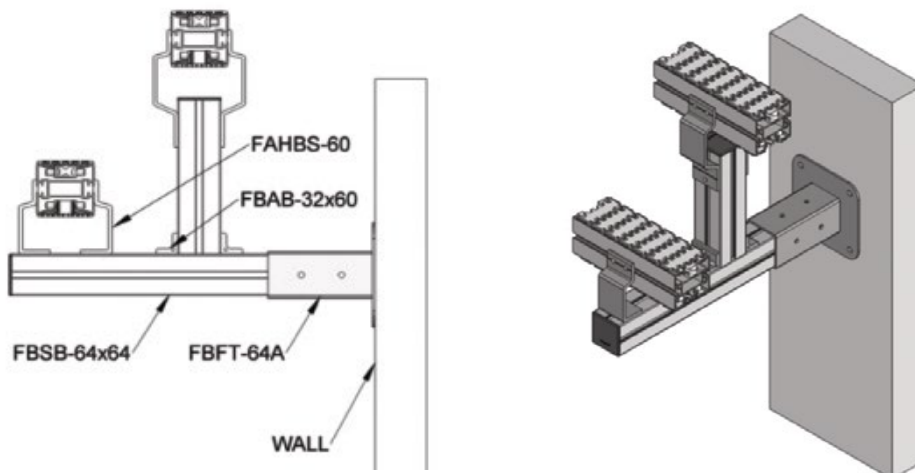

FBSB-40x40 Support Beam 40x40 – Aluminum Anodized

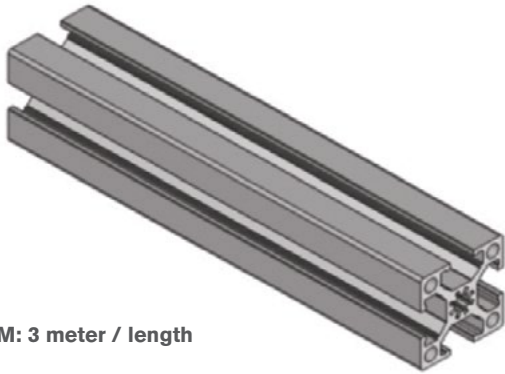

UOM: 3 meter / length

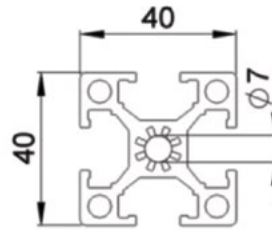

FBSB-64x64 Support Beam 64x64 – Aluminum Anodized

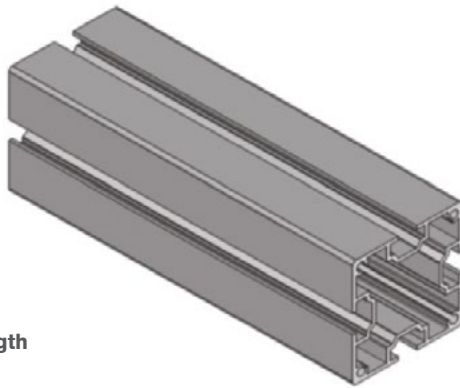

UOM: 3 meter / length

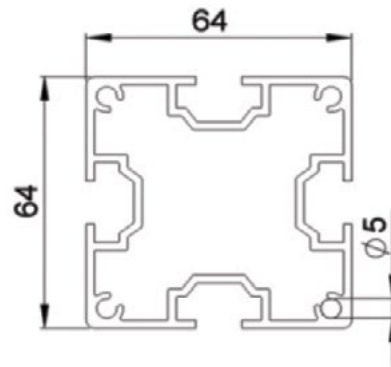

FBSB-64x64C Close slot Support Beam – Aluminum Anodized

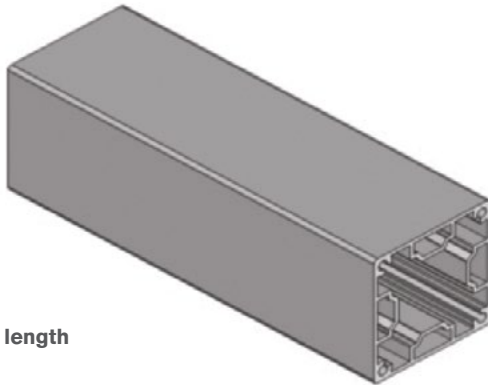

UOM: 3 meter / length

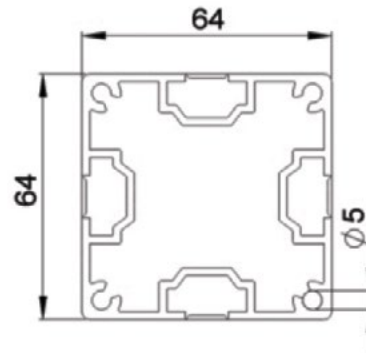

FBSB-80x80 Support Beam 80x80 – Aluminum Anodized

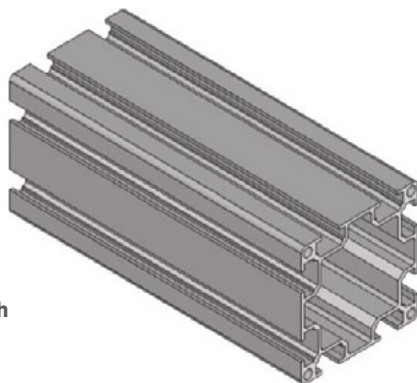

UOM: 3 meter / length

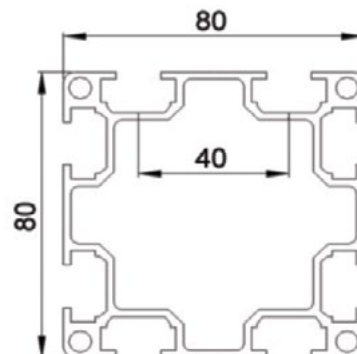

FBSB-40x80

Support Beam – Aluminum Anodized

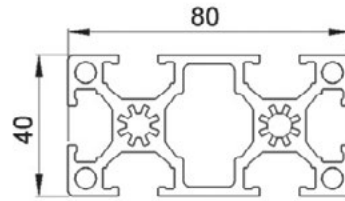
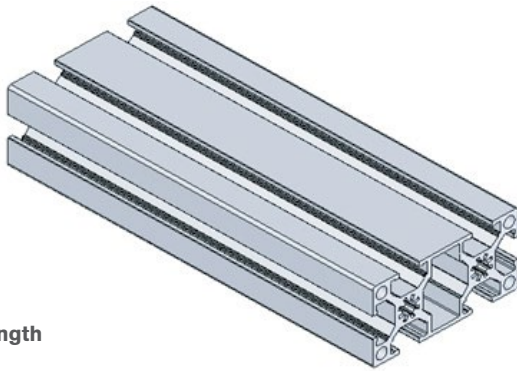

UOM: 3 meter / length

FBSB-40x80C

Close Slot Support Beam - Aluminum Anodized

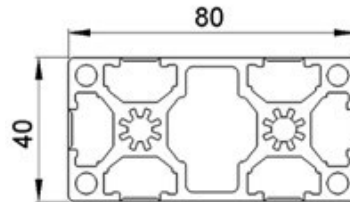
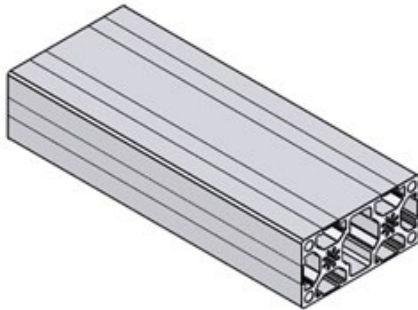

UOM: 3 meter / length

FBEC-40x80

End Cap. 40x80 mm Support Beam - Polyamide

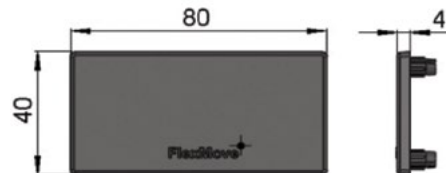
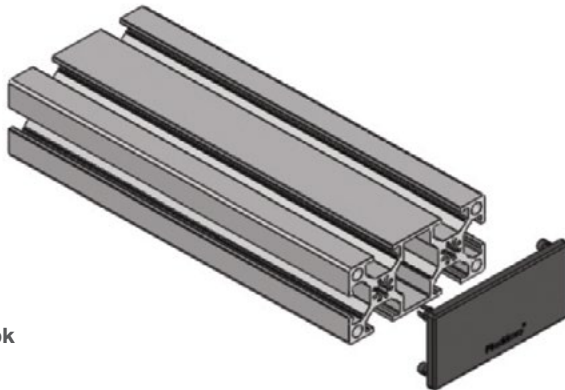

UOM: 10 pcs / pk

FBEC-40

End Cap , 40x40 mm Support Beam - Polyamide

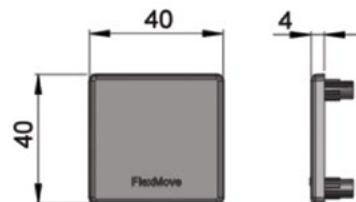
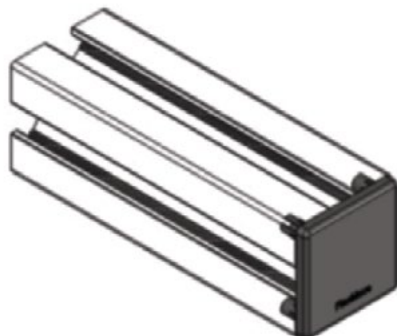

UOM: 10 pcs / pk

FBEC-64

End cap , 64x64mm Support Beam - Polyamide

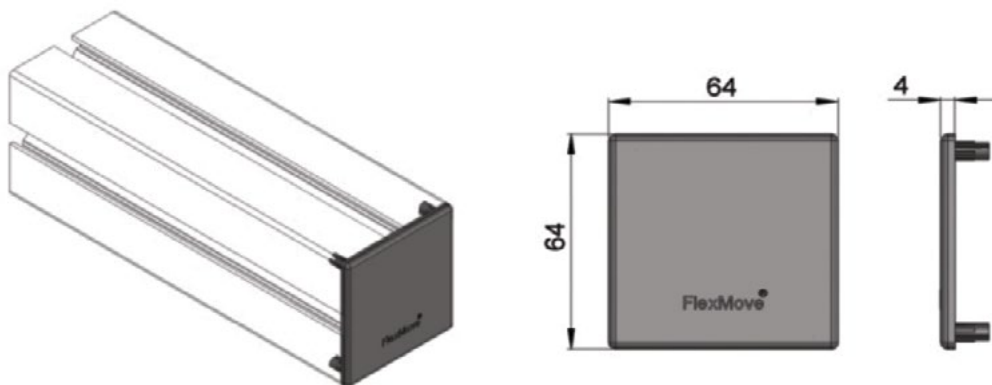

UOM: 10 pcs / pk

FBEC-80

End cap , 80x80 mm Support Beam - Polyamide

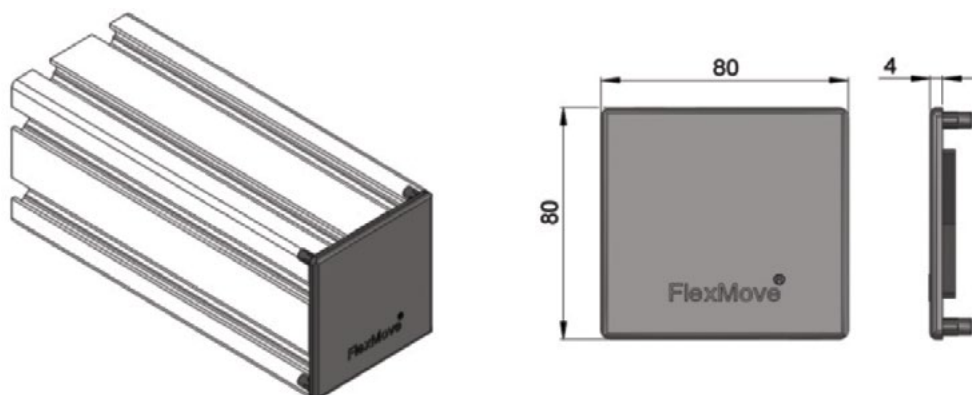

UOM: 10 pcs / pk

FBFT-64

Foot For Support Beam 64x64 – Aluminum Die Cast

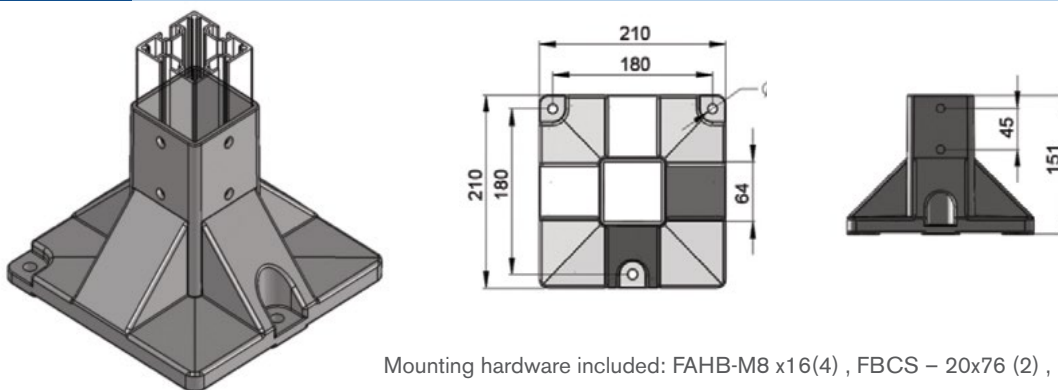

UOM: pc

Mounting hardware included: FAHB-M8 x16(4) , FBCE – 20x76 (2) , FAFW-M8 (4)

FBFT-64A

Foot For Support Beam 64x64 – Steel, Powder Coating

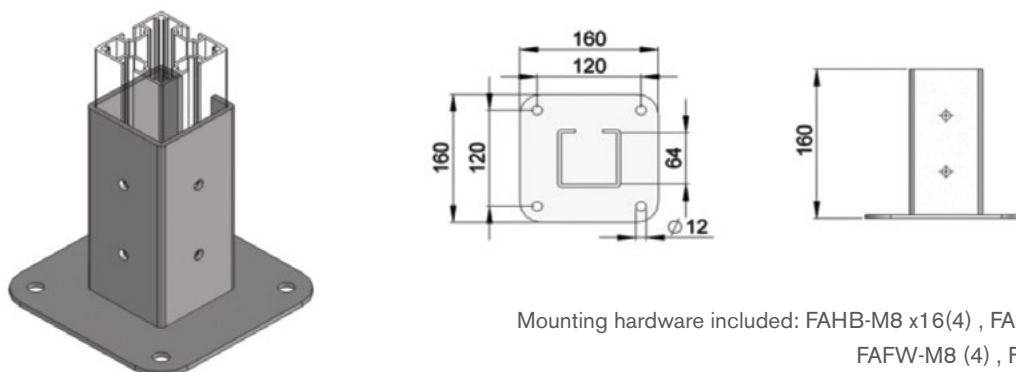

UOM: pc

Mounting hardware included: FAHB-M8 x16(4) , FASN – M8 (4) , FAFW-M8 (4) , FAWP-M10(4)

FBFT-64B

Foot For Support Beam 64x64 – Aluminum

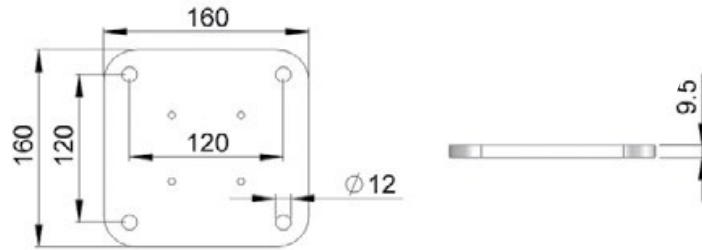
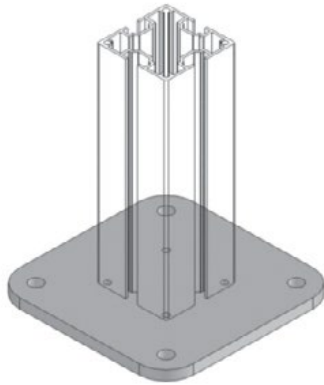

UOM: pc

Mounting: FACS-M6 x 20 (4) , FAWP-M10 (4)

FBCS-20x76

Connecting Strip For Foot – Steel, Electro Zinc Plated

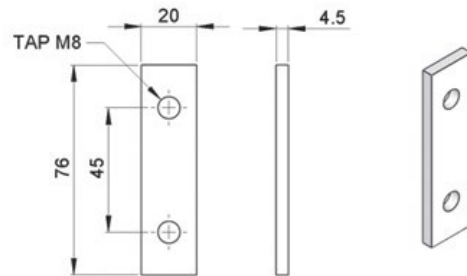
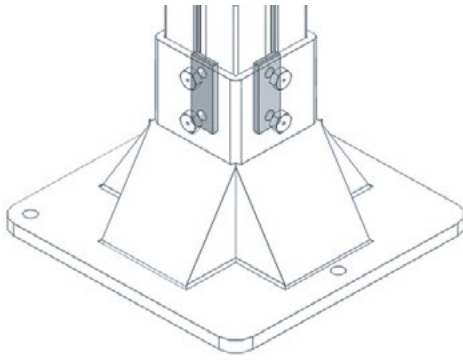

UOM: 10pcs / pk

FBCS-20x96

Connecting Strip For Foot 80x80 mm– Steel, Electro Zinc Plated

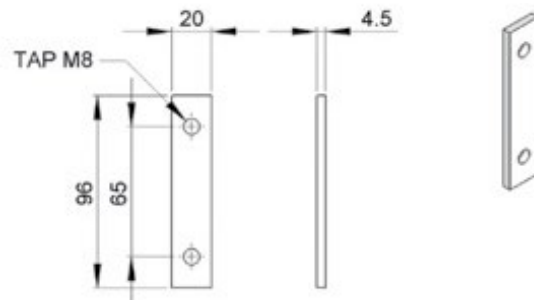
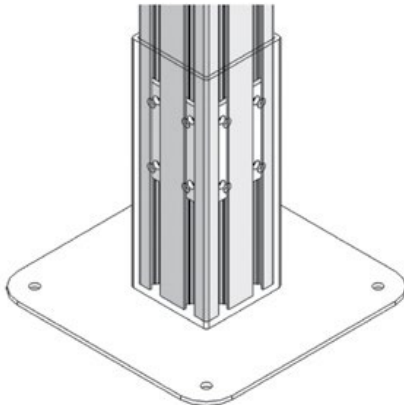

UOM: pc

FBFT-64TP

Tripod Foot For FBSB-64x64 - Polyamide , Glass Fiber reinforced

Plastic Pad, screws and clamps included

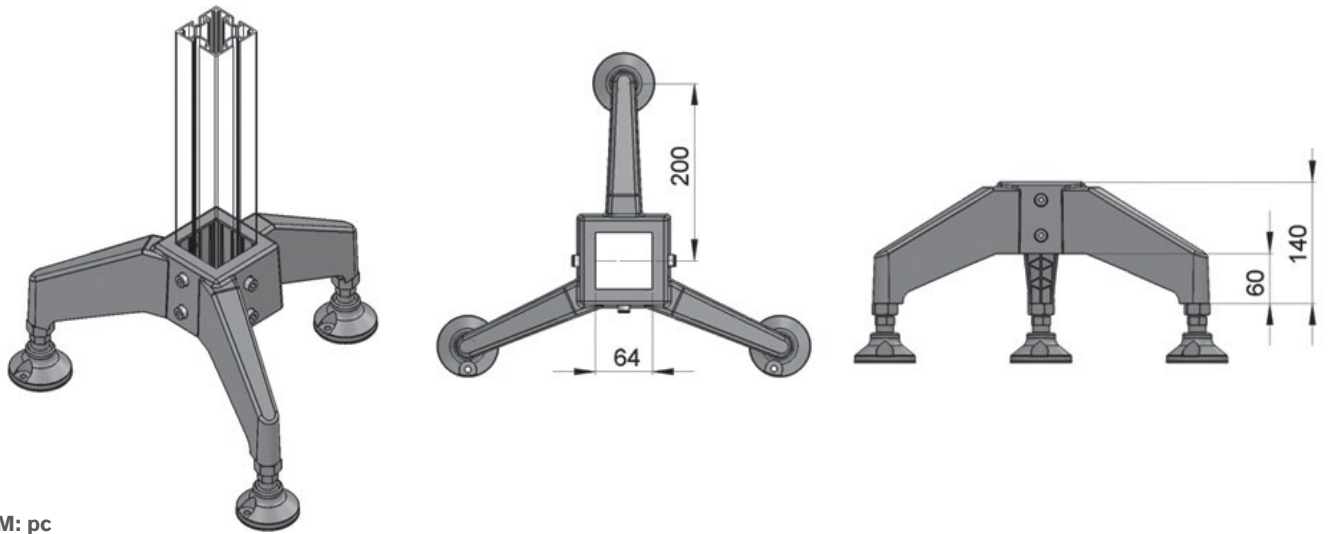

UOM: pc

FBFT-64BP

Bipod Foot For FBSB-64x64 - Polyamide , Glass Fiber reinforced

Plastic Pad, screws and clamps included

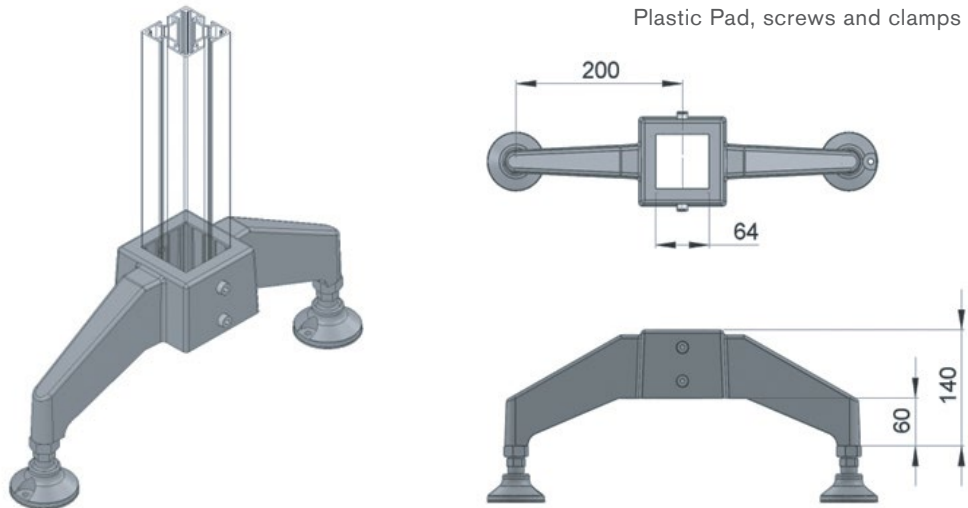

UOM: pc

FBFT-80TP

Tripod Foot For FBSB-80x80 - Polyamide, Glass Fiber reinforced

Plastic Pad, screws and clamps included

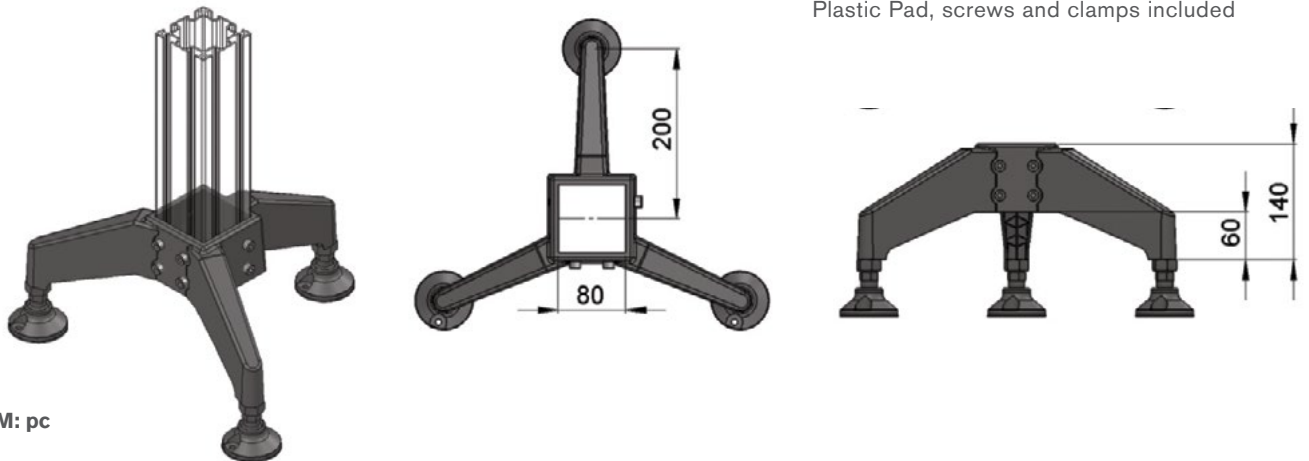

UOM: pc

FBFT-80BP

Bipod Foot For FBSB-80x80 - Polyamide , Glass Fiber reinforced

Plastic Pad, screws and clamps included

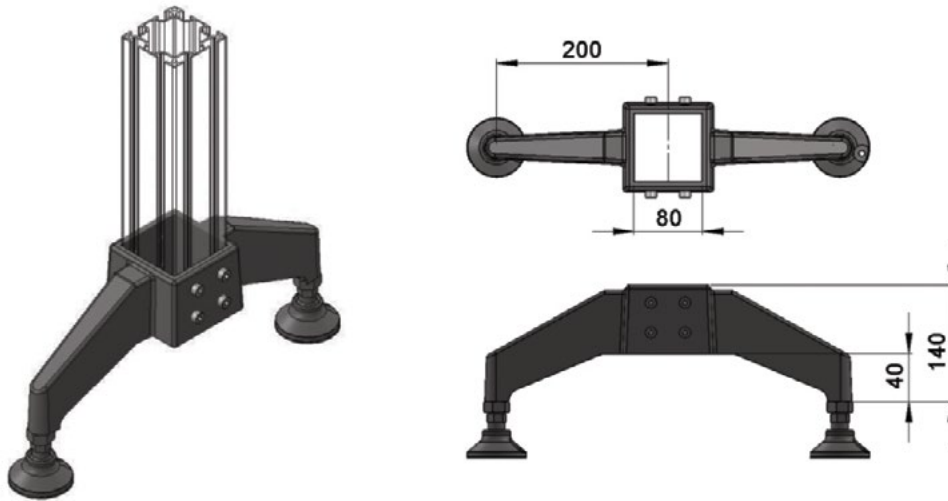

UOM: pc

FBFT-64xM8

End Plate for Support Beam 64x64- Aluminum & Adjustable stand - D=M8, L=50 - Zinc Plated

FBFT-64xM10

End Plate for Support Beam 64x64- Aluminum & Adjustable stand - D=M10, L=75 - Zinc Plated

FBFT-64xM12

End Plate for Support Beam 64x64- Aluminum & Adjustable stand - D=M12, L=75 - Zinc Plated

FBFT-64xM8S

End Plate for Support Beam 64x64- Aluminum & Adjustable stand - D=M8, L=50 - Stainless Steel

FBFT-64xM10S

End Plate for Support Beam 64x64- Aluminum & Adjustable stand - D=M10, L=75 - Stainless Steel

FBFT-64xM12S

End Plate for Support Beam 64x64- Aluminum & Adjustable stand - D=M12, L=75 - Stainless Steel

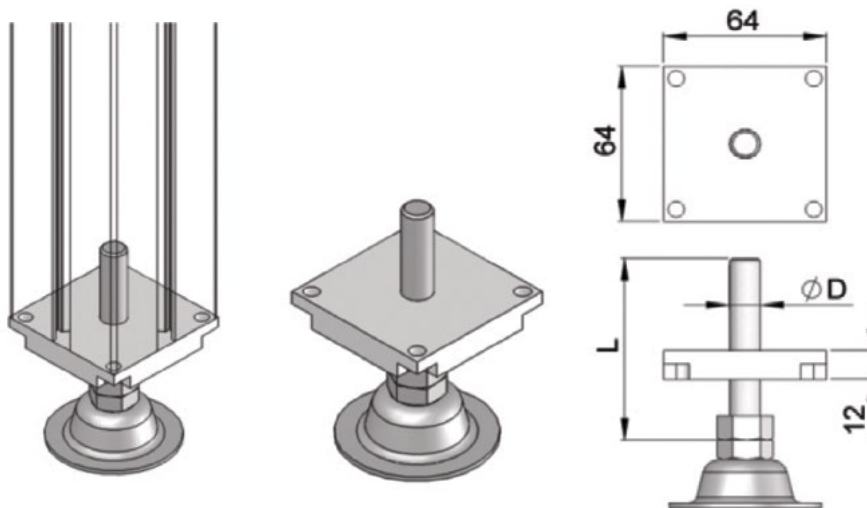

UOM: pc

FBFT-170 Floor Attachment Bracket – Steel, Zinc Plated

FBFT-170S Floor Attachment Bracket – Stainless Steel

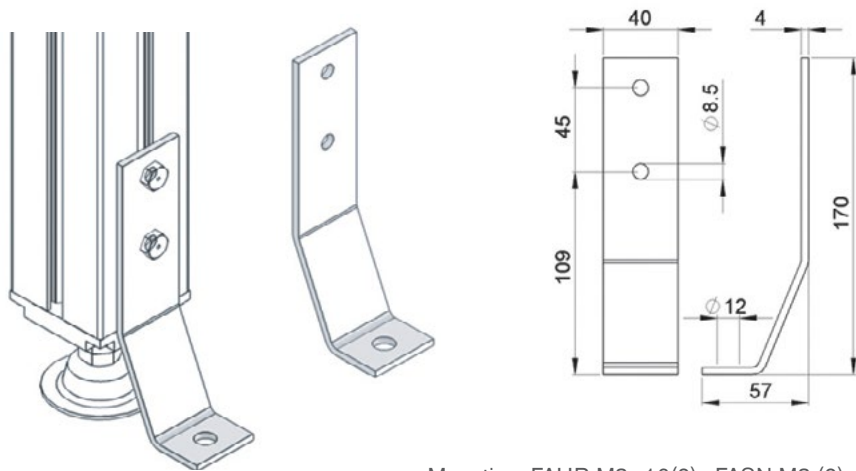

UOM: pc

Mounting: FAHB-M8 x16(2) , FASN-M8 (2) , FAFW-M8 (3) , FAWP-M10 (1)

Foot For Support Beam 80x80 – Steel, Powder Coating

FBFT-80A Foot For Support Beam 80x80 – Steel, Powder Coating

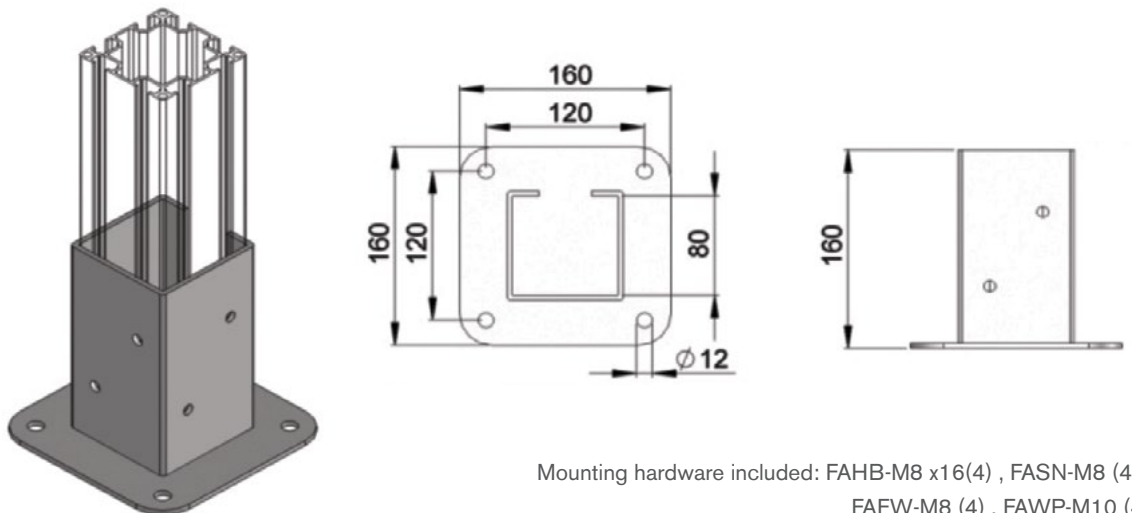

UOM: pc

Mounting hardware included: FAHB-M8 x16(4) , FASN-M8 (4) , FAFW-M8 (4) , FAWP-M10 (4)

FBFT-80B Foot For Support Beam 80x80 – Steel, Powder Coating

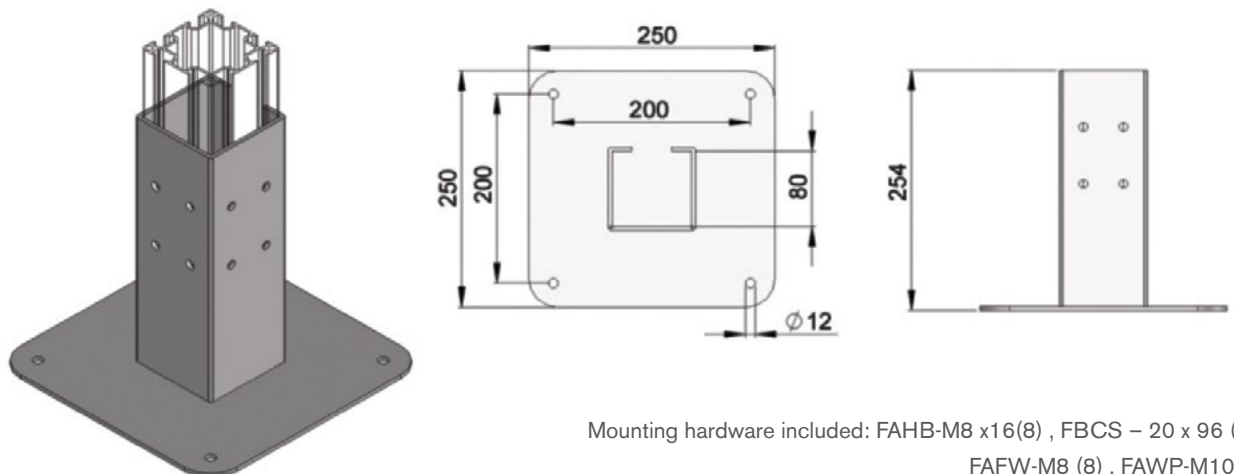

UOM: pc

Mounting hardware included: FAHB-M8 x16(8) , FBCS – 20 x 96 (4) , FAFW-M8 (8) , FAWP-M10(4)

FBFT-80D

Foot For Support Beam 80x80 – Steel, Powder Coating

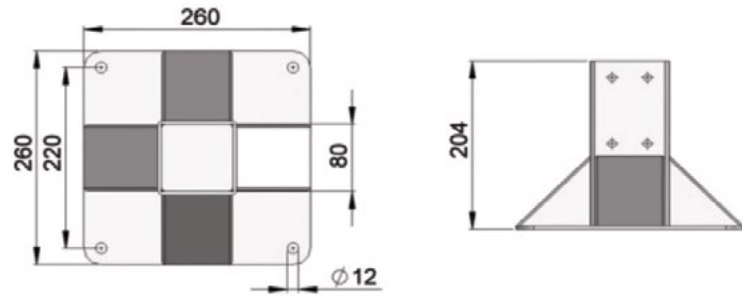
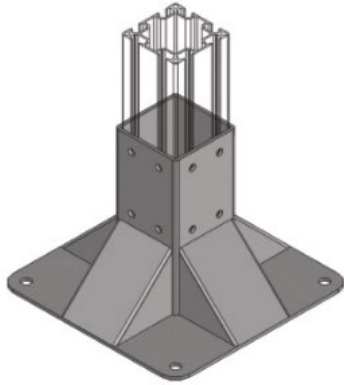

UOM: pc

Mounting: FAHB-M8 x16(8) , FBCS – 20 x 96 (4) , FAFW-M8 (8) , FAWP-M10 (4)

FBCP-40T

T Connecting Plate for Support Beam 40x40- Steel, Zinc Plated

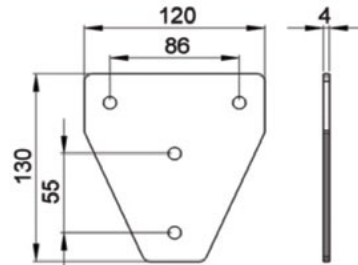
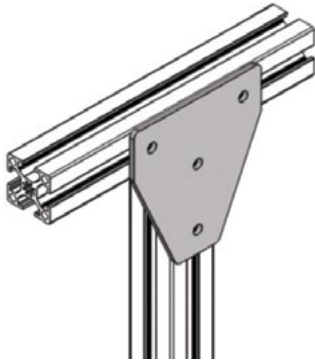

UOM: pc

Mounting: FAHB-M8 x16(4) , FASN-M8 (4) , FAFW-M8 (4)

FBCP-40L

L Connecting Plate for Support Beam 40x40- Steel, Zinc Plated

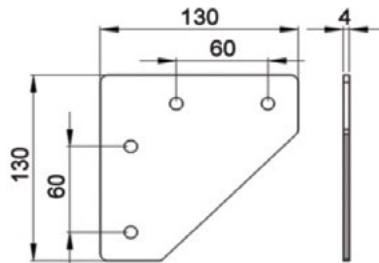
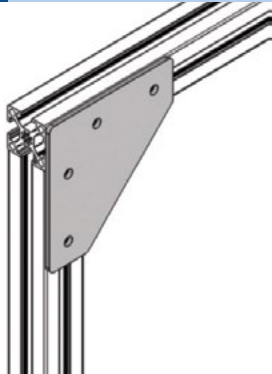

UOM: pc

Mounting: FAHB-M8 x16(4) , FASN-M8 (4) , FAFW-M8 (4)

FBCP-64T

T connecting Plate for Support Beam 64x64 – Steel, Zinc Plated

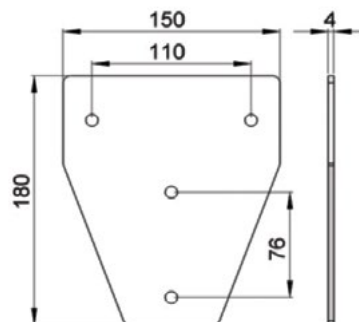
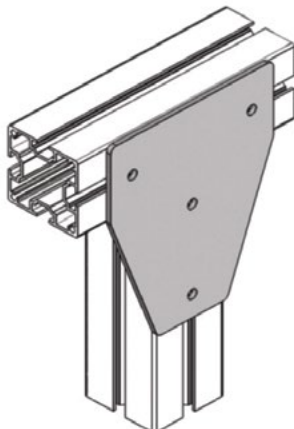

UOM: pc

Mounting: FAHB-M8 x16(4) , FASN-M8 (4) , FAFW-M8 (4)

FBCP-64L L Connecting Plate for Support Beam 64x64- Steel, Zinc Plated

UOM: pc

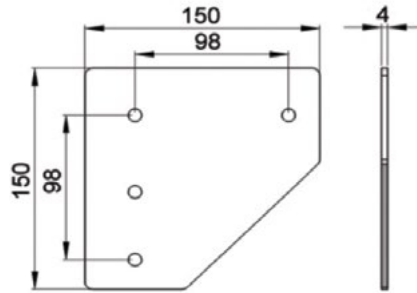
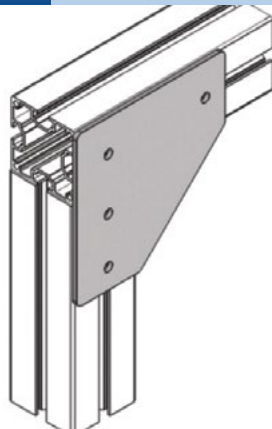

Mounting: FAHB-M8 x16(4) , FASN-M8 (4) , FAFW-M8 (4)

FBCP-80T T connecting Plate for Support Beam 80x80 – Steel, Zinc Plated

UOM: pc

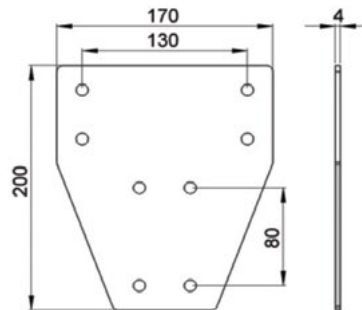
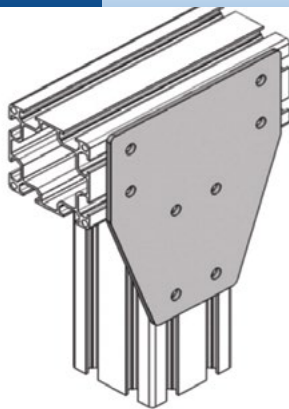

Mounting: FAHB-M8 x16(8) , FASN-M8 (8) , FAFW-M8 (8)

FBCP-80L L Connecting Plate for Support Beam 80x80- Steel, Zinc Plated

UOM: pc

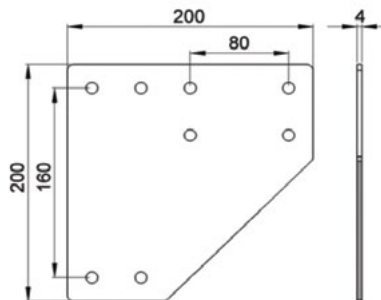
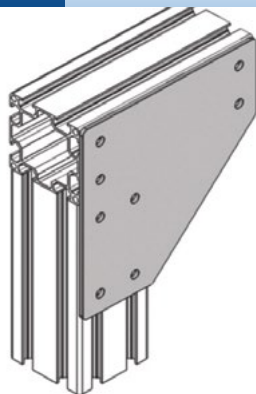

Mounting: FAHB-M8 x16(8) , FASN-M8 (8) , FAFW-M8 (8)

FBCP-40V

45° connecting Plate for Support Beam 40x40 – Steel, Zinc Plated

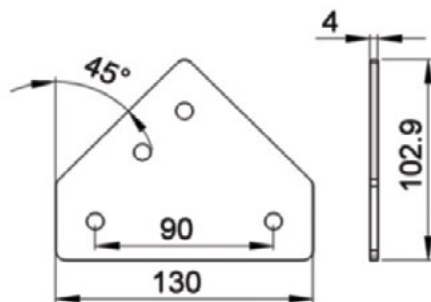
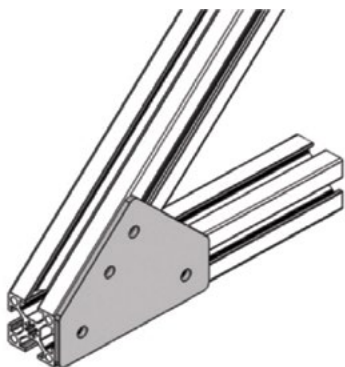

UOM: pc

Mounting: FAHB-M8 x16(4), FASN-M8 (4), FAFW-M8 (4)

FBCP-64V

45° connecting Plate for Support Beam 64x64 – Steel, Zinc Plated

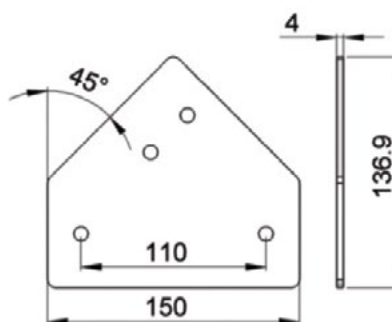
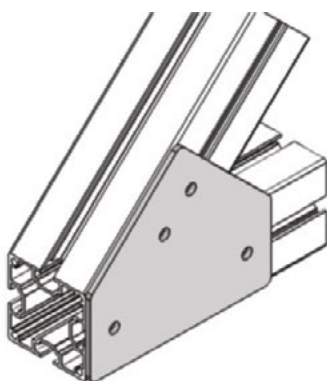

UOM: pc

Mounting: FAHB-M8 x16(4), FASN-M8 (4), FAFW-M8 (4)

FBCP-80V

45° connecting Plate for Support Beam 80x80 – Steel, Zinc Plated

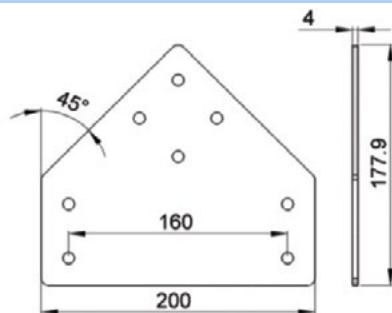
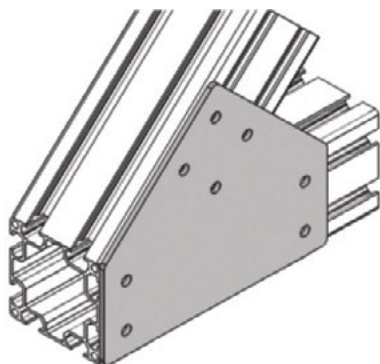

UOM: pc

Mounting: FAHB-M8 x16(8), FASN-M8 (8), FAFW-M8 (8)

FBRX-20A

90° Inner Joint Strip – Steel, Zinc Plated

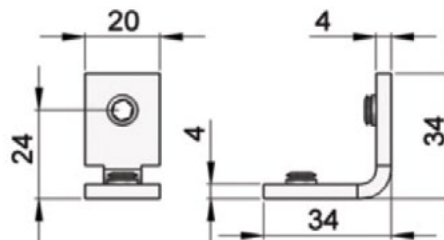
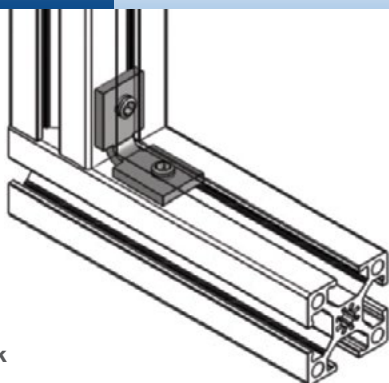

UOM: 10 pcs / pk

FBRX-20B

90° Outer Joint Strip – Steel, Zinc Plated

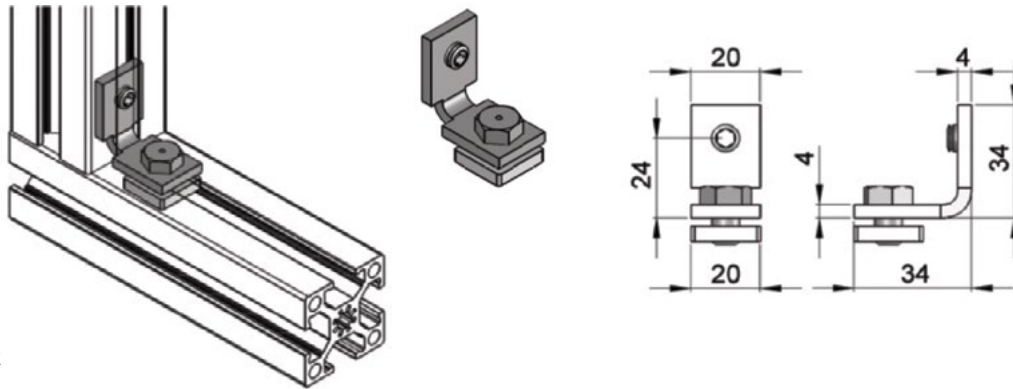

UOM: 10 pcs / pk

FBRX-20C

90° Inner Joint Strip – Steel, Zinc Plated

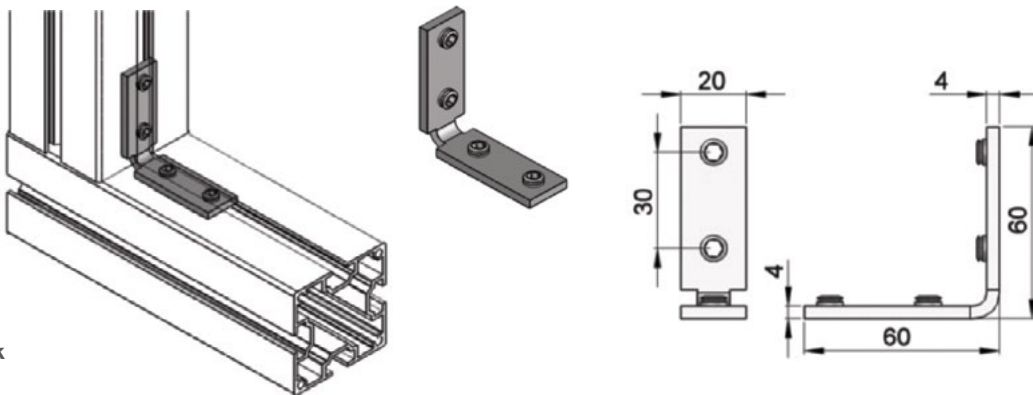

UOM: 10 pcs / pk

FBAB-40x40

Angle Bracket for Support Beam 40x40 - Aluminum

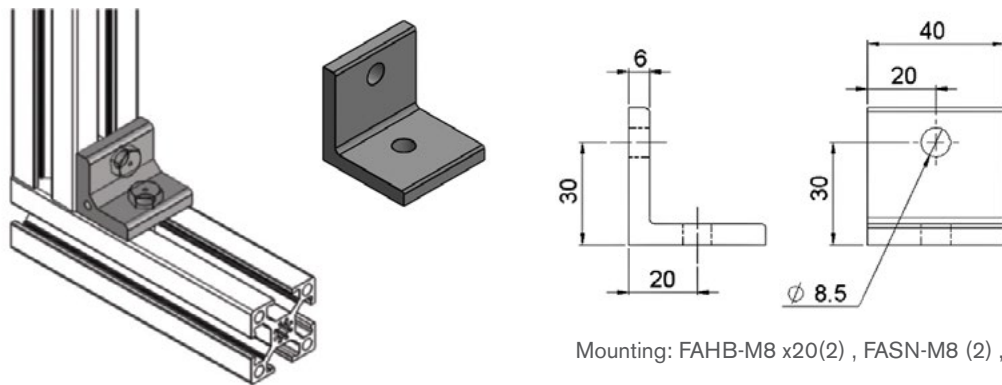

UOM: pc

Mounting: FAHB-M8 x20(2) , FASN-M8 (2) , FAFW-M8 (2)

FBAB-32x60

Angle Bracket for Support Beam 64x64 - Aluminum

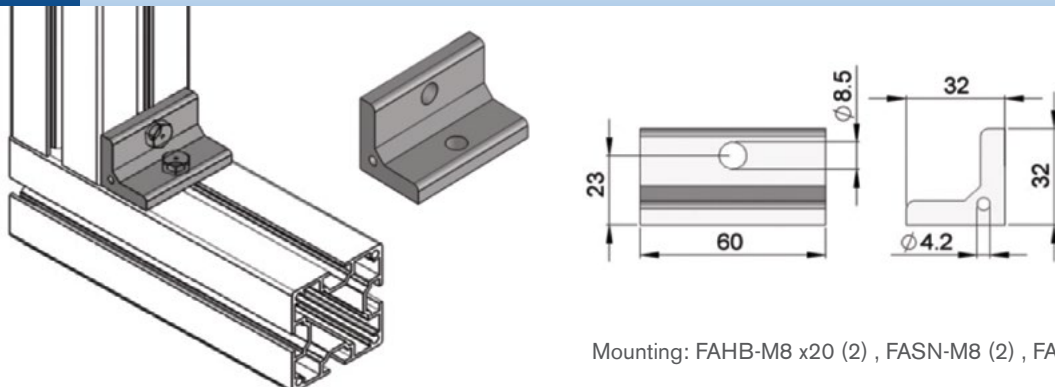

UOM: pc

Mounting: FAHB-M8 x20 (2) , FASN-M8 (2) , FAFW-M8 (2)

FBAB-32x80

Angle Bracket for Support Beam 80x80 - Aluminum

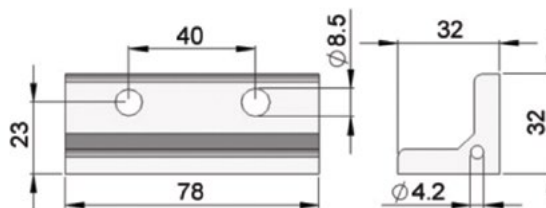
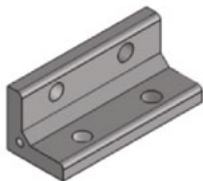
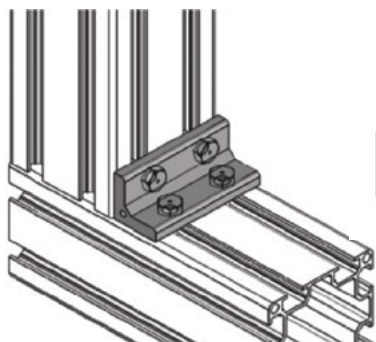

UOM: pc

Mounting: FAHB-M8 x20 (4), FASN-M8 (4), FAFW-M8 (4)

FBAB-40L

Angle Bracket for Support Beam 40x40 - Aluminum

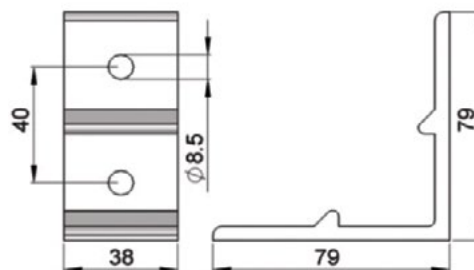
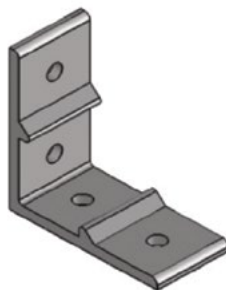
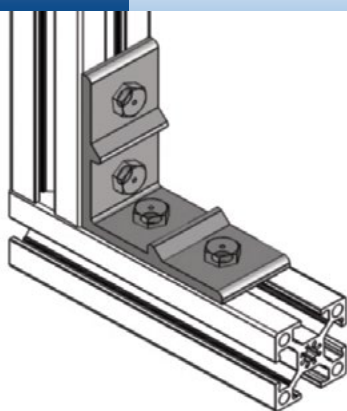

UOM: pc

Mounting: FAHB-M8 x 16 (4), FASN-M8 (4), FAFW-M8 (4)

FBAB-60L

Angle Bracket for Support Beam 64x64 - Aluminum

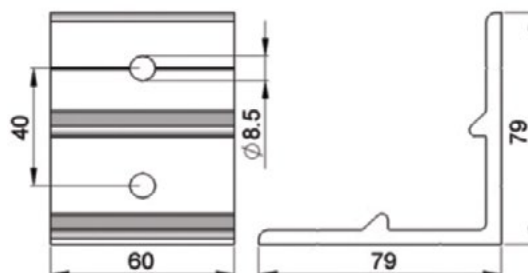
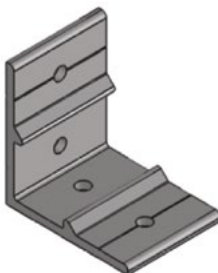
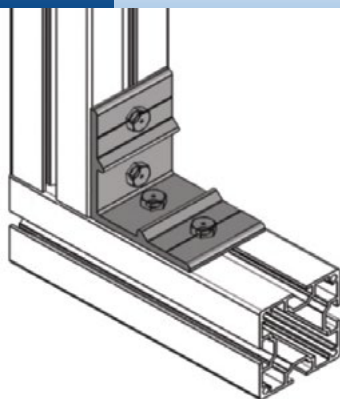

UOM: pc

Mounting: FAHB-M8 x 16 (4), FASN-M8 (4), FAFW-M8 (4)

FBAB-80L

Angle Bracket for Support Beam 80x80 - Aluminum

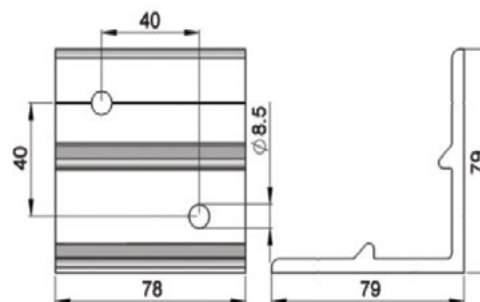
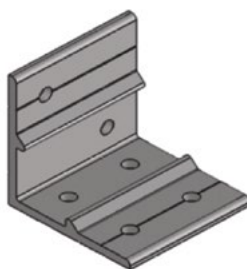
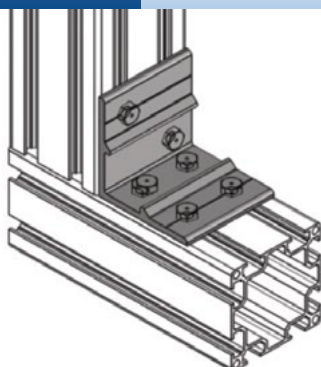

UOM: pc

Mounting: FAHB-M8 x 16 (6), FASN-M8 (6), FAFW-M8 (6)

FBAB-40x80A

Angle Bracket for Support Beam 40x40, 64x64, 40x80 - Aluminum Die Cast

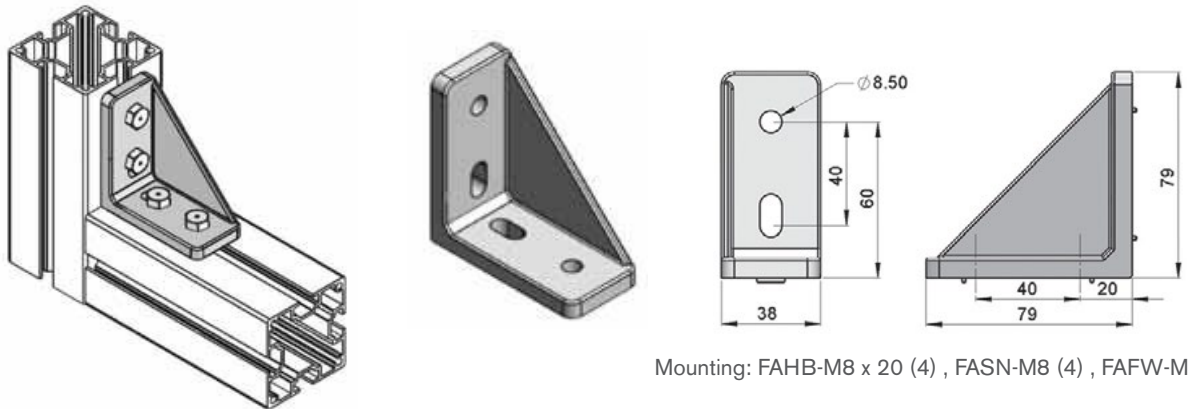

UOM: pc

Mounting: FAHB-M8 x 20 (4) , FASN-M8 (4) , FAFW-M8 (4)

FBAB-40x40A

Angle Bracket for Support Beam 40x40 - Aluminum Die Cast

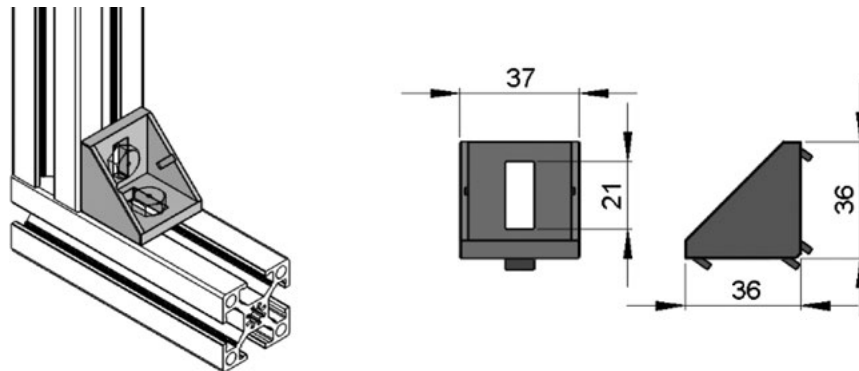

UOM: pc

FBAB-64x64A

Angle Bracket for Support Beam 64x64 - Aluminum Die Cast

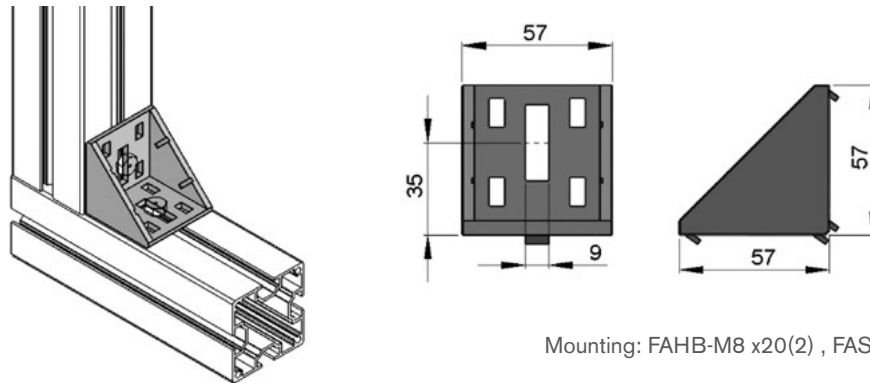

UOM: pc

Mounting: FAHB-M8 x20(2) , FASN-M8 (2) , FAFW-M8 (2)

FBAB-80x80A

Angle Bracket for Support Beam 80x80 - Aluminum Die Cast

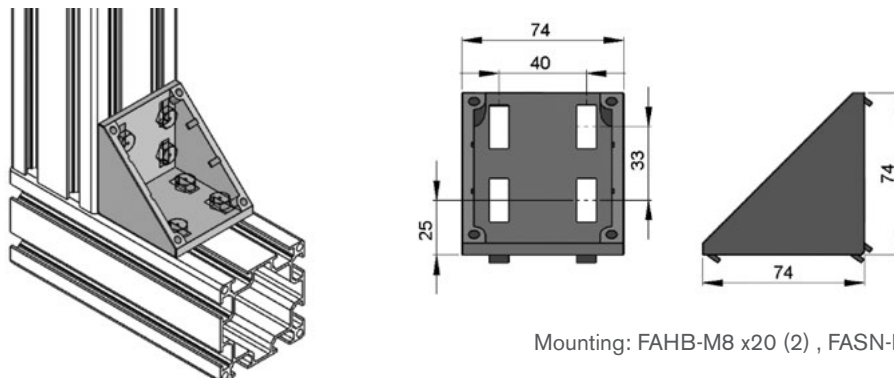

UOM: pc

Mounting: FAHB-M8 x20 (2) , FASN-M8 (2) , FAFW-M8 (2)

FBEC-40x40A

End Cap for FBAB-40x40A angle bracket - Polyamide

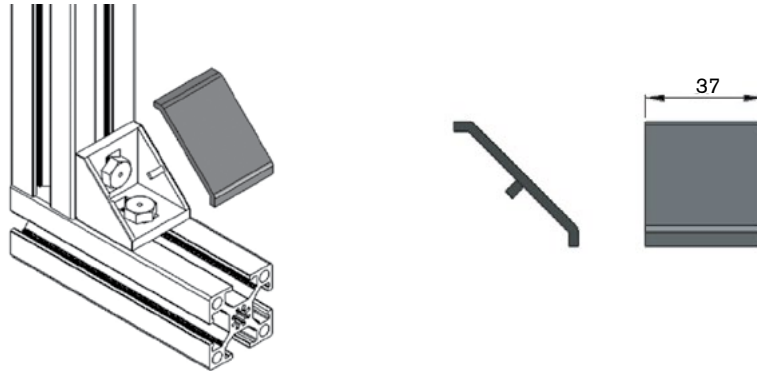

UOM: pc

FBEC-64x64A

End Cap for FBAB-64x64A angle bracket - Polyamide

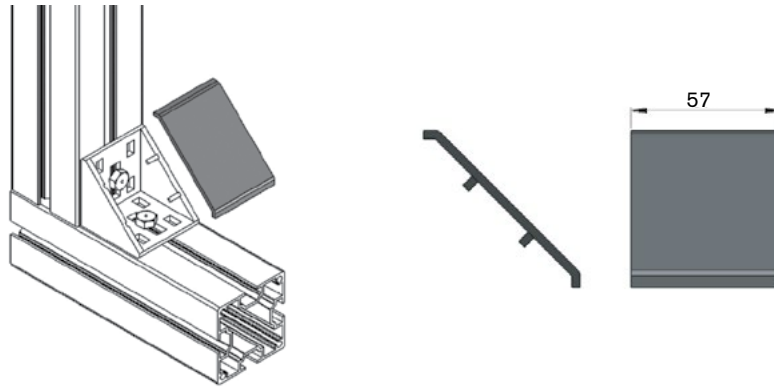

UOM: pc

FBEC-80x80A

End Cap for FBAB-80x80A angle bracket - Polyamide

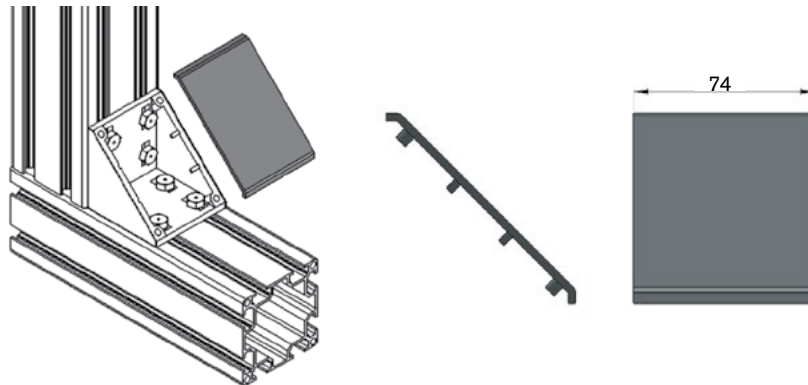

UOM: pc

FGRB-16x54

Fixed Guide Rail Assembly

FGRB-16x54 Assembly

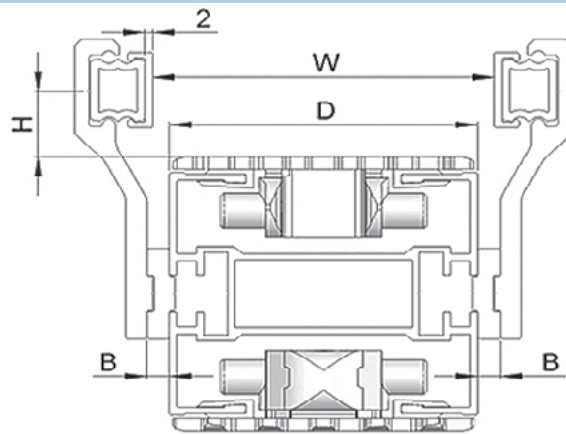
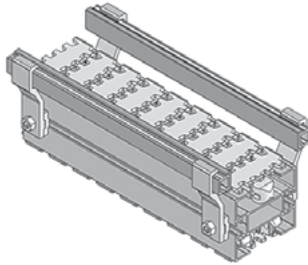

B Spacer = FGRD-6

See page 203
for components

Guide Rail Bracket	Series	D (mm)	H (mm)	W (mm) B = 0	W (mm) B = 6.3	W (mm) B = 12.6	W (mm) B = 18.9
FGRB-16X54	FK	45	26	41.7	54.3	66.9	79.5
FGRB-16X54	FS	65	26	61.7	74.3	86.9	99.5
FGRB-16X54	FM	85	20	81.7	94.3	106.9	119.5
FGRB-16X54	FC	105	20	101.7	114.3	126.9	139.5
FGRB-16X54	FL	150	20	146.7	159.3	171.9	184.5
FGRB-16X54	FU	179	20	175.7	188.3	200.9	213.5
FGRB-16X54	FV	260	20	256.7	269.3	281.9	294.5

FGRB-16x42

Fixed Guide Rail Assembly

FGRB-16x42 Assembly

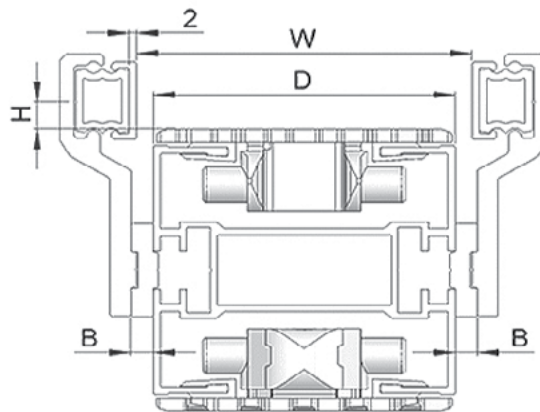
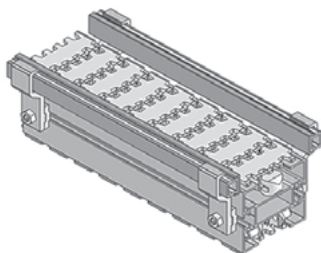

B Spacer = FGRD-6

See page 203
for components

Guide Rail Bracket	Series	D (mm)	H (mm)	W (mm) B = 0	W (mm) B = 6.3	W (mm) B = 12.6	W (mm) B = 18.9
FGRB-16X42	FK	45	14	41.7	54.3	66.9	79.5
FGRB-16X42	FS	65	14	61.7	74.3	86.9	99.5
FGRB-16X42	FM	85	8	-	94.3	106.9	119.5
FGRB-16X42	FC	105	8	-	114.3	126.9	139.5
FGRB-16X42	FL	150	8	-	159.3	171.9	184.5
FGRB-16X42	FU	179	8	-	188.3	200.9	213.5
FGRB-16X42	FV	260	8	-	269.3	281.9	294.5

FGRB-28x42

Fixed Guide Rail Assembly

FGRB-28x42 Assembly

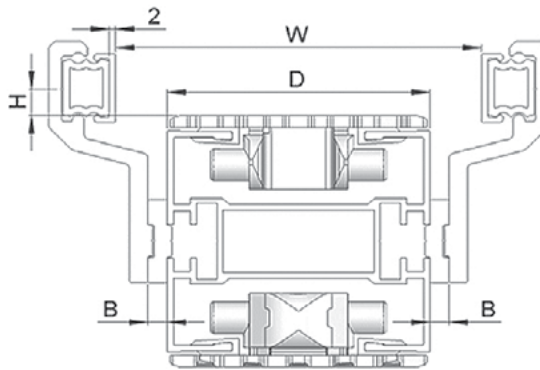
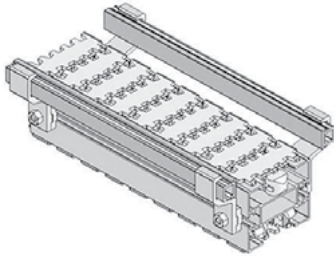

B Spacer = FGRD-6

See page 203
for components

Guide Rail Bracket	Series	D (mm)	H (mm)	W (mm) B = 0	W (mm) B = 6.3	W (mm) B = 12.6	W (mm) B = 18.9
FGRB-28X42	FK	45	14	65.8	78.4	91	103.6
FGRB-28X42	FS	65	14	85.8	98.4	111	123.6
FGRB-28X42	FM	85	8	105.8	118.4	131	143.6
FGRB-28X42	FC	105	8	125.8	138.4	151	163.6
FGRB-28X42	FL	150	8	170.8	183.4	196	208.6
FGRB-28X42	FU	179	8	199.8	212.4	225	237.6
FGRB-28X42	FV	260	8	280.8	293.4	306	318.6

FGRB-40x42

Fixed Guide Rail Assembly

FGRB-40x42 Assembly

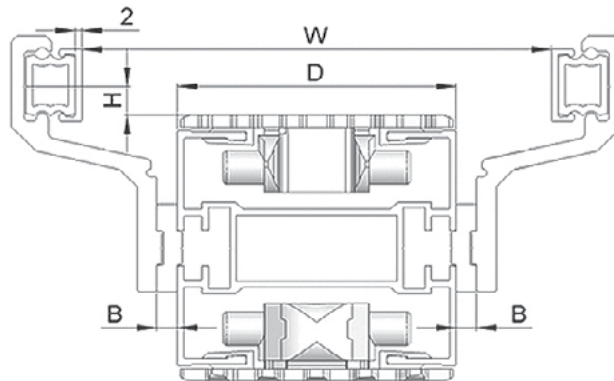
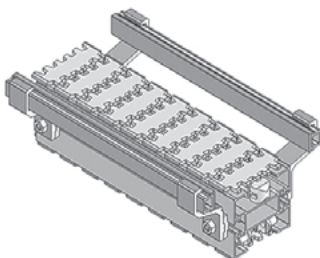

B Spacer = FGRD-6

See page 203
for components

Guide Rail Bracket	Series	D (mm)	H (mm)	W (mm) B = 0	W (mm) B = 6.3	W (mm) B = 12.6	W (mm) B = 18.9
FGRB-40X42	FK	45	14	90.6	103.2	115.8	128.4
FGRB-40X42	FS	65	14	110.6	123.2	135.8	148.4
FGRB-40X42	FM	85	8	130.6	143.2	155.8	168.4
FGRB-40X42	FC	105	8	150.6	163.2	175.8	188.4
FGRB-40X42	FL	150	8	195.6	163.2	220.8	233.4
FGRB-40X42	FU	179	8	224.6	237.2	249.8	262.4
FGRB-40X42	FV	260	8	305.6	318.2	330.8	343.4

FGRB-49x42 Fixed Guide Rail Assembly

FGRB-49x42 Assembly

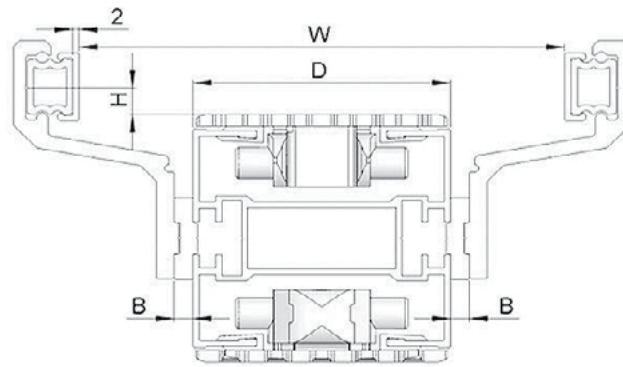
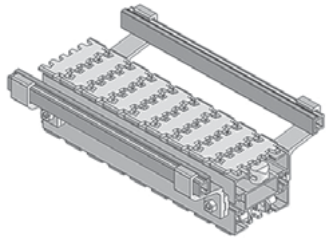

B Spacer = FGRD-6

See page 204 for components

Guide Rail Bracket	Series	D (mm)	H (mm)	W (mm) B = 0	W (mm) B = 6.3	W (mm) B = 12.6	W (mm) B = 18.9
FGRB-49X42	FK	45	14	107.8	120.4	133	145.6
FGRB-49X42	FS	65	14	127.8	140.4	153	165.6
FGRB-49X42	FM	85	8	147.8	160.4	173	185.6
FGRB-49X42	FC	105	8	167.8	180.4	193	205.6
FGRB-49X42	FL	150	8	212.8	225.4	238	250.6
FGRB-49X42	FU	179	8	241.8	254.4	267	279.6
FGRB-49X42	FV	260	8	322.8	335.4	348	360.6

FGRB-53x42 Fixed Guide Rail Assembly

FGRB-53x42 Assembly

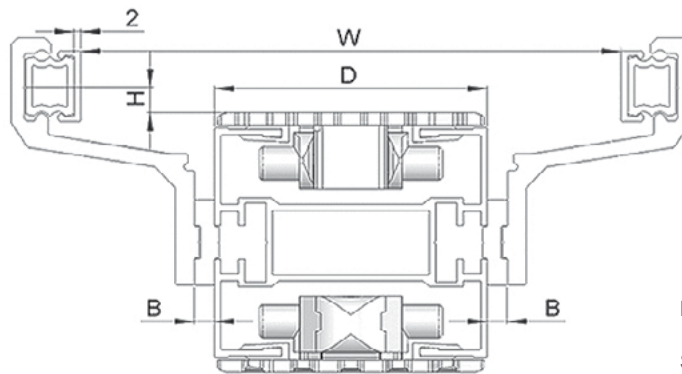
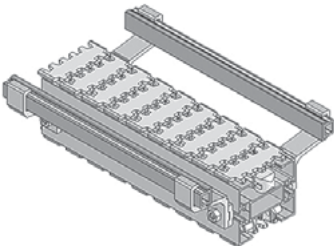

B Spacer = FGRD-6

See page 204 for components

Guide Rail Bracket	Series	D (mm)	H (mm)	W (mm) B = 0	W (mm) B = 6.3	W (mm) B = 12.6	W (mm) B = 18.9
GRB-53X42	FK	45	14	115.7	128.3	140.9	153.5
FGRB-53X42	FS	65	14	135.7	148.3	160.9	173.5
FGRB-53X42	FM	85	8	155.7	168.3	180.9	193.5
FGRB-53X42	FC	105	8	175.7	188.3	200.9	213.5
FGRB-53X42	FL	150	8	220.7	233.3	245.9	258.5
FGRB-53X42	FU	179	8	249.7	262.3	274.9	287.5
FGRB-53X42	FV	260	8	330.7	343.3	355.9	368.5

FGRB-90x42

Fixed Guide Rail Assembly

FGRB-90x42 Assembly

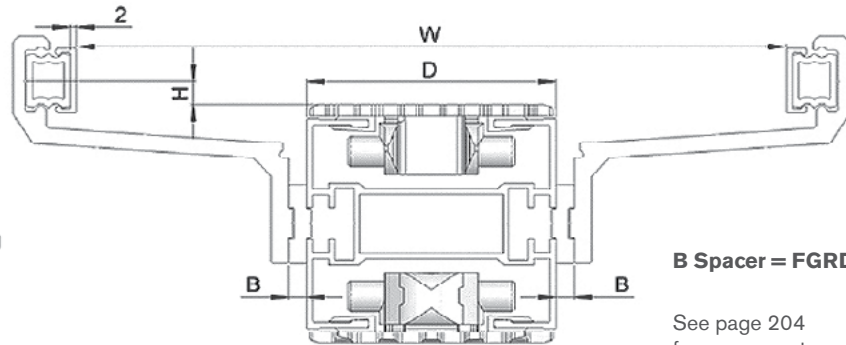
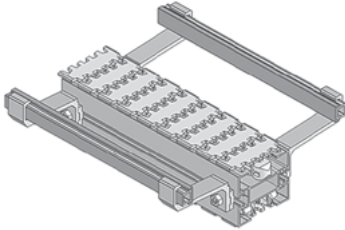

B Spacer = FGRD-6

See page 204 for components

Guide Rail Bracket	Series	D (mm)	H (mm)	W (mm) B = 0	W (mm) B = 6.3	W (mm) B = 12.6	W (mm) B = 18.9
FGRB-90X42	FK	45	14	190.3	202.9	215.5	228.1
FGRB-90X42	FS	65	14	210.3	222.9	235.5	248.1
FGRB-90X42	FM	85	8	230.3	242.9	255.5	268.1
FGRB-90X42	FC	105	8	250.3	262.9	275.5	288.1
FGRB-90X42	FL	150	8	295.3	307.9	320.5	333.1
FGRB-90X42	FU	179	8	324.3	336.9	349.5	362.1
FGRB-90X42	FV	260	8	405.3	417.9	430.5	443.1

FGHS-30/FGHS-70

Fixed High Side Guide Assembly

FGHS-30/70 Assembly

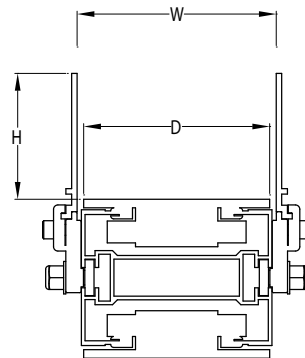
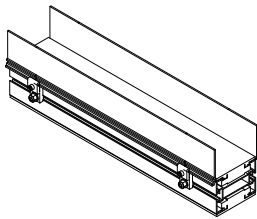

See page 218 for components

Guide Rail Bracket	Series	D (mm)	FGHS-30 Rail		FGHS-70 Rail	
			H (mm)	H (mm)	W (mm) B = 0	
FGRD-HS	FK	45	37	75	49	
FGRD-HS	FS	65	31	70	69	
FGRD-HS	FM	85	31	70	89	
FGRD-HS	FC	105	31	70	109	
FGRD-HS	FL	150	31	70	159	
FGRD-HS	FU	179	31	70	183	
FGRD-HS	FV	260	31	70	264	

FGRA-22HD

Heavy Duty Fully Adjustable Guide Assembly

FGRA-22HD Assembly

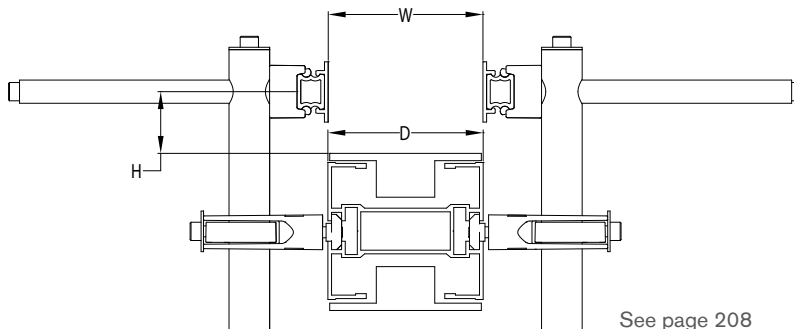
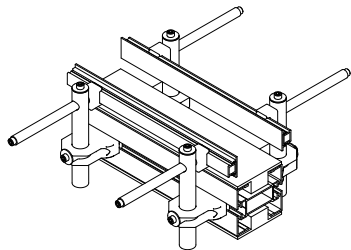

See page 208
for components

Bracket Assembly	Series	D (mm)	H (mm) Min	H (mm) Max	W (mm) Min	W (mm) Max
FGRA-22HD	FK	45	17	82	0	39
FGRA-22HD	FS	65	17	76	0	59
FGRA-22HD	FM	85	17	76	0	79
FGRA-22HD	FC	105	17	76	0	99
FGRA-22HD	FL	150	17	76	0	144
FGRA-22HD	FU	179	17	76	0	170
FGRA-22HD	FV	260	17	76	30	254

FGRA-22HDT

Heavy Duty Tool-less Fully Adjustable Guide Assembly

FGRA-22HDT Assembly

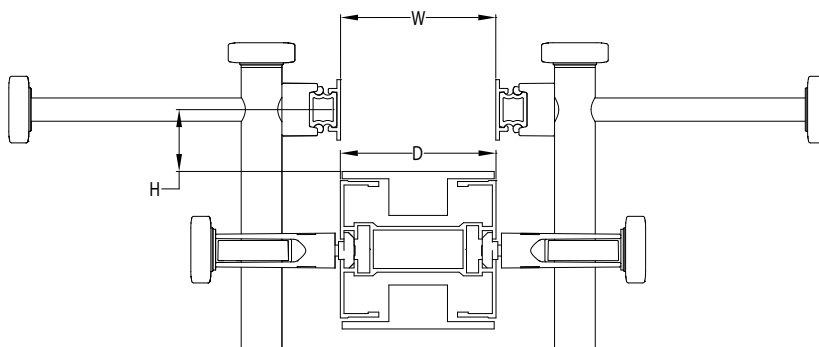
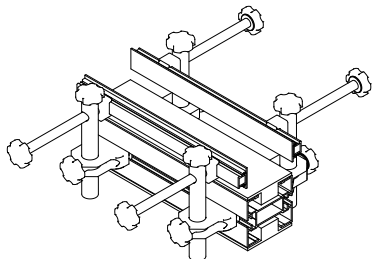

See page 208
for components

Bracket Assembly	Series	D (mm)	H (mm) Min	H (mm) Max	W (mm) Min	W (mm) Max
FGRA-22HDT	FK	45	17	82	0	39
FGRA-22HDT	FS	65	17	76	0	59
FGRA-22HDT	FM	85	17	76	0	79
FGRA-22HDT	FC	105	17	76	0	99
FGRA-22HDT	FL	150	17	76	0	144
FGRA-22HDT	FU	179	17	76	0	170
FGRA-22HDT	FV	260	17	76	30	254

FGPG-A/FGPG-U

Pallet/Puck Guide Assembly

FGPG-A/FHPG-U Assembly

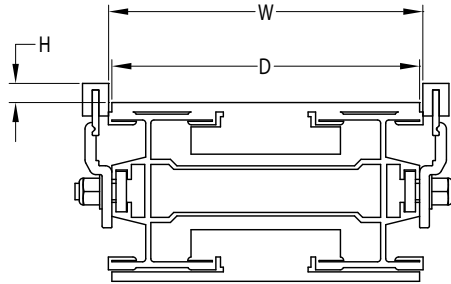
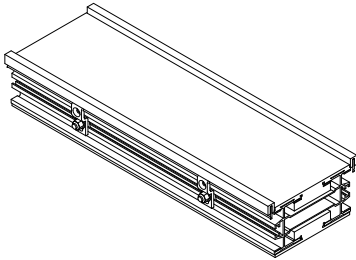

See page 219
for components

Bracket	Series	D (mm)	H (mm)	W (mm) B = 0
FGRB-PG	FK	45	24	48
FGRB-PG	FS	65	18	68
FGRB-PG	FM	85	18	88
FGRB-PG	FC	105	18	108
FGRB-PG	FL	150	18	153
FGRB-PG	FU	179	18	182
FGRB-PG	FV	260	18	263

Note:

- Available in North America Only
- Pallets available for FC Series Only
- H can be lowered by 9.5 mm for pallet transfer

FGRA-8x39x45 Adjustable Guide Rail Assembly

FGRA-8x39x45 Assembly

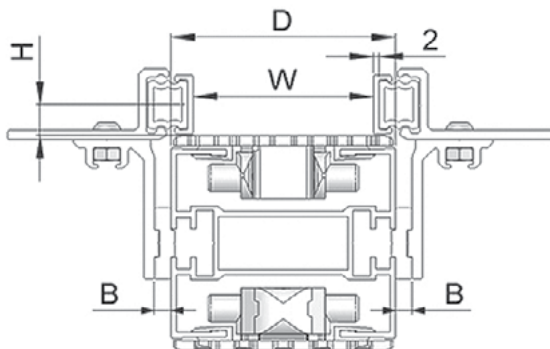
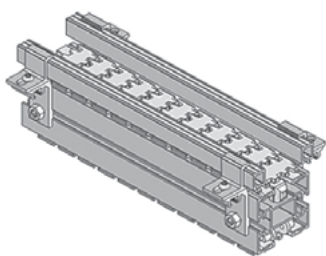

B Spacer = FGRD-6

See page 202 for components

Guide Rail Bracket	Series	D (mm)	H (mm)	W (mm) min B = 0	W (mm) max B = 0	W (mm) min B = 6.3	W (mm) max B = 6.3
FGRA-8x39x45	FK	45	17	0	24.8	0	37.4
FGRA-8x39x45	FS	65	17	0	44.8	0	57.4
Guide Rail Bracket	Series	D (mm)	H (mm)	W (mm) min B = 12.6	W (mm) max B = 12.6	W (mm) min B = 1839	W (mm) max B = 18.9
FGRA-8x39x45	FM	85	11	86	90	86	102.6
FGRA-8x39x45	FC	105	11	106	110	106	122.6
FGRA-8x39x45	FL	150	11	156	160	156	172.6
FGRA-8x39x45	FU	179	11	180	184	180	196.6
FGRA-8x39x45	FV	260	11	261	265	261	277.6

FGRA-26x39x45 Adjustable Guide Rail Assembly

FGRA-26x39x45 Assembly

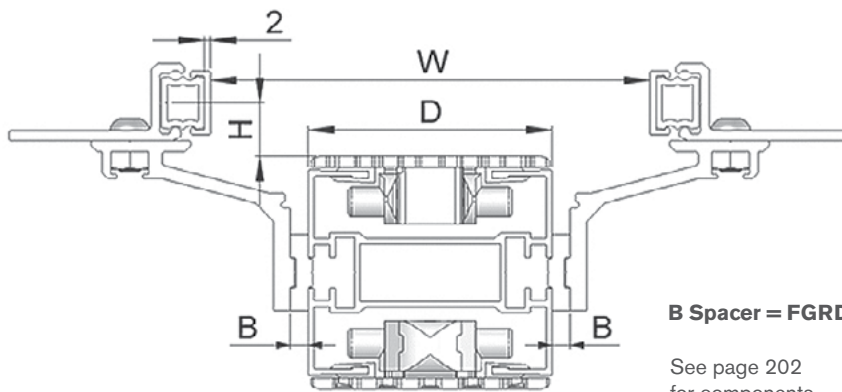
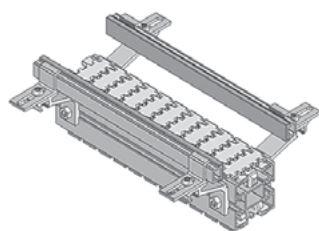

B Spacer = FGRD-6

See page 202 for components

Guide Rail Bracket	Series	D (mm)	H (mm)	W (mm) min B = 0	W (mm) max B = 0	W (mm) min B = 6.3	W (mm) max B = 6.3
FGRA-26x39x45	FK	45	24	28.8	100.8	41.4	113.4
FGRA-26x39x45	FS	65	24	48.8	120.8	61.4	133.4
FGRA-26x39x45	FM	85	18	68.8	140.8	81.4	153.4
FGRA-26x39x45	FC	105	18	88.8	160.8	101.4	173.4
FGRA-26x39x45	FL	150	18	133.8	205.8	146.4	218.4
FGRA-26x39x45	FU	179	18	162.8	234.8	175.4	251.4
FGRA-8x39x45	FV	260	18	243.8	315.8	256.4	328.4

FGRS-18 & FGDT- & FGRR-

Guide Rail Assembly

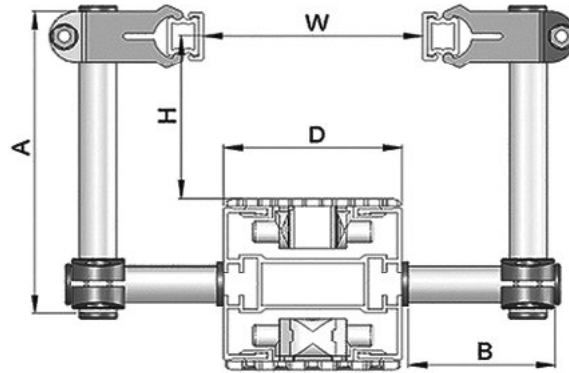

See pages 201, 206 and 210 for components

A (mm)	Series	D (mm)	H (mm) Min	H (mm) Max
FGGR-18XLLL	FK	45	17	35
FGGR-18XLLL	FS	65	17	35
FGGR-18XLLL	FM	85	17	35
FGGR-18XLLL	FC	105	17	30
FGGR-18XLLL	FL	150	17	30
FGGR-18XLLL	FU	179	17	35
FGGR-18XLLL	FV	260	17	35
FGRR-150	FK	45	17	85
FGRR-150	FS	65	17	85
FGRR-150	FM	85	17	80
FGRR-150	FC	105	17	80
FGRR-150	FL	150	17	80
FGRR-150	FU	179	17	80
FGRR-150	FV	260	17	80
FGRR-200	FK	45	17	135
FGRR-200	FS	65	17	135
FGRR-200	FM	85	17	130
FGRR-200	FC	105	17	130
FGRR-200	FL	150	17	130
FGRR-200	FU	179	17	130
FGRR-200	FV	260	17	130
FGRR-250	FK	45	17	185
FGRR-250	FS	65	17	185
FGRR-250	FM	85	17	180
FGRR-250	FC	105	17	180
FGRR-250	FL	150	17	180
FGRR-250	FU	179	17	180
FGRR-250	FV	260	17	180

B (mm)	Series	D (mm)	W (mm) Min	W (mm) Max
FGDT-70	FK	45	0	65
FGDT-70	FS	65	0	85
FGDT-70	FM	85	16	105
FGDT-70	FC	105	36	125
FGDT-70	FL	150	81	170
FGDT-70	FU	179	110	199
FGDT-70	FV	260	191	280
FGDT-100	FK	45	0	125
FGDT-100	FS	65	0	145
FGDT-100	FM	85	16	165
FGDT-100	FC	105	36	185
FGDT-100	FL	150	81	230
FGDT-100	FU	179	110	259
FGDT-100	FV	260	191	340
FGDT-150	FK	45	0	225
FGDT-150	FS	65	0	245
FGDT-150	FM	85	16	265
FGDT-150	FC	105	36	285
FGDT-150	FL	150	81	330
FGDT-150	FU	179	110	359
FGDT-150	FV	260	191	440
FGDT-200	FK	45	0	325
FGDT-200	FS	65	0	345
FGDT-200	FM	85	16	365
FGDT-200	FC	105	36	385
FGDT-200	FL	150	81	430
FGDT-200	FU	179	110	459
FGDT-200	FV	260	191	540

- FGRL-18x110C & FGDT-70
- FGRL-18x110C & FGDT-100
- FGRL-18x110C & FGDT-150
- FGRL-18x110C & FGDT-200
- FGRL-18x160C & FGDT-70
- FGRL-18x160C & FGDT-100
- FGRL-18x160C & FGDT-150
- FGRL-18x160C & FGDT-200

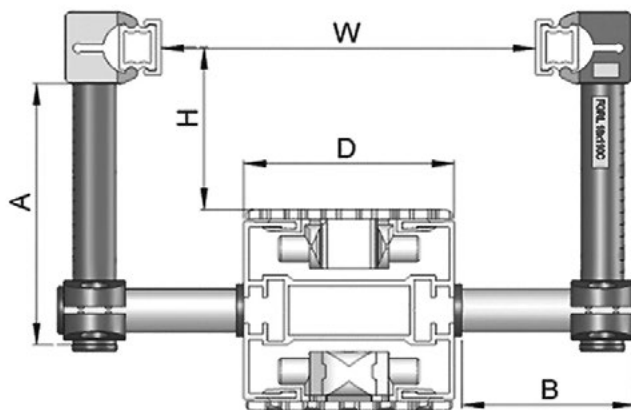

Note:
Plastic guide supports used for light products.

Guide Rail Assembly

See pages 201 and 211 for components

A (mm)	Series	D (mm)	H (mm) Min	H (mm) Max
FGRL-18x110C	FK	45	14	70
FGRL-18x110C	FS	65	14	70
FGRL-18x110C	FM	85	14	65
FGRL-18x110C	FC	105	14	65
FGRL-18x110C	FL	150	14	65
FGRL-18x110C	FU	179	14	65
FGRL-18x110C	FV	260	14	65
FGRL-18x160C	FK	45	14	120
FGRL-18x160C	FS	65	14	120
FGRL-18x160C	FM	85	14	115
FGRL-18x160C	FC	105	14	115
FGRL-18x160C	FL	150	14	115
FGRL-18x160C	FU	179	14	115
FGRL-18x160C	FV	260	14	115

B (mm)	Series	D (mm)	W (mm) Min	W (mm) Max
FGDT-70	FK	45	23	110
FGDT-70	FS	65	43	130
FGDT-70	FM	85	63	150
FGDT-70	FC	105	83	170
FGDT-70	FL	150	128	215
FGDT-70	FU	179	157	244
FGDT-70	FV	260	238	325
FGDT-100	FK	45	23	170
FGDT-100	FS	65	43	190
FGDT-100	FM	85	63	210
FGDT-100	FC	105	83	230
FGDT-100	FL	150	128	275
FGDT-100	FU	179	157	304
FGDT-100	FV	260	238	385
FGDT-150	FK	45	23	270
FGDT-150	FS	65	43	290
FGDT-150	FM	85	63	310
FGDT-150	FC	105	83	330
FGDT-150	FL	150	128	375
FGDT-150	FU	179	157	404
FGDT-150	FV	260	238	485
FGDT-200	FK	45	23	370
FGDT-200	FS	65	43	390
FGDT-200	FM	85	63	410
FGDT-200	FC	105	83	430
FGDT-200	FL	150	128	475
FGDT-200	FU	179	157	504
FGDT-200	FV	260	238	585

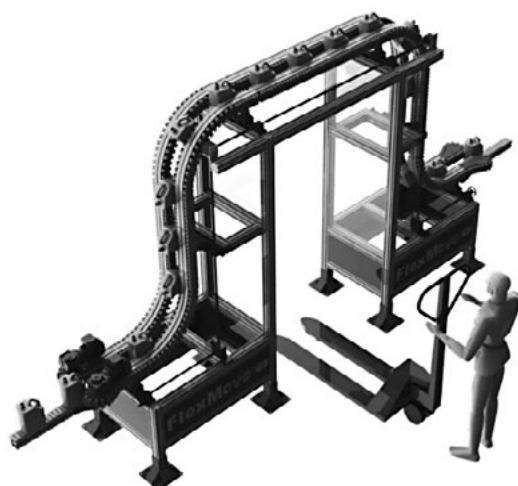

- FGRL-18x110CA & FGDT-70
- FGRL-18x110CA & FGDT-100
- FGRL-18x110CA & FGDT-150
- FGRL-18x110CA & FGDT-200
- FGRL-18x160CA & FGDT-70
- FGRL-18x160CA & FGDT-100
- FGRL-18x160CA & FGDT-150
- FGRL-18x160CA & FGDT-200

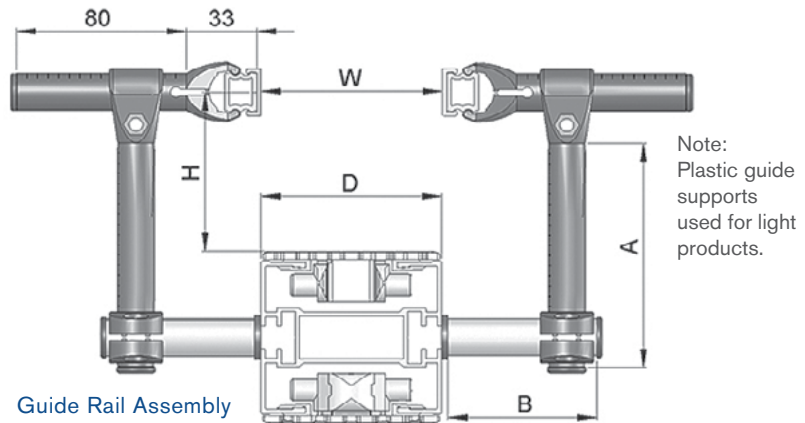

See pages 201 and 211 for components

A (mm)	Series	D (mm)	H (mm) Min	H (mm) Max
FGRL-18x110CA	FK	45	14	70
FGRL-18x110CA	FS	65	14	70
FGRL-18x110CA	FM	85	14	65
FGRL-18x110CA	FC	105	14	65
FGRL-18x110CA	FL	150	14	65
FGRL-18x110CA	FU	179	14	65
FGRL-18x110CA	FV	260	14	65
FGRL-18x160CA	FK	45	14	120
FGRL-18x160CA	FS	65	14	120
FGRL-18x160CA	FM	85	14	115
FGRL-18x160CA	FC	105	14	115
FGRL-18x160CA	FL	150	14	115
FGRL-18x160CA	FU	179	14	115
FGRL-18x160CA	FV	260	14	115

B (mm)	Series	D (mm)	W (mm) Min	W (mm) Max
FGDT-70	FK	45	0	68
FGDT-70	FS	65	0	88
FGDT-70	FM	85	0	108
FGDT-70	FC	105	0	128
FGDT-70	FL	150	0	173
FGDT-70	FU	179	0	202
FGDT-70	FV	260	65	283
FGDT-100	FK	45	0	128
FGDT-100	FS	65	0	148
FGDT-100	FM	85	0	168
FGDT-100	FC	105	0	188
FGDT-100	FL	150	0	233
FGDT-100	FU	179	0	262
FGDT-100	FV	260	65	343
FGDT-150	FK	45	0	228
FGDT-150	FS	65	0	248
FGDT-150	FM	85	0	268
FGDT-150	FC	105	0	288
FGDT-150	FL	150	0	333
FGDT-150	FU	179	0	362
FGDT-150	FV	260	65	443
FGDT-200	FK	45	0	328
FGDT-200	FS	65	0	348
FGDT-200	FM	85	0	368
FGDT-200	FC	105	0	388
FGDT-200	FL	150	0	433
FGDT-200	FU	179	0	462
FGDT-200	FV	260	65	543



FGRL-18x110C & FGRF-42x18V

Guide Rail Assembly

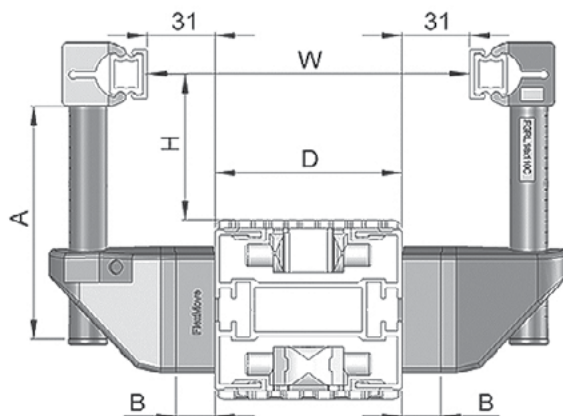

Note:
Plastic guide supports used for light products.

B Spacer = FGRD-18A

See pages 211 and 213 for components

Guide Rail	Guide Rail	Series	D (mm)	A (mm)	H (mm) Min	H (mm) Max	W (mm) B = 0	W (mm) B = 18	W (mm) B = 36
FGRL-18x110C	FGRF-42x18V	FK	45	110	3	75	71	107	143
FGRL-18x110C	FGRF-42x18V	FS	65	110	3	75	91	127	163
FGRL-18x110C	FGRF-42x18V	FM	85	110	3	70	111	147	183
FGRL-18x110C	FGRF-42x18V	FC	105	110	3	70	131	167	203
FGRL-18x110C	FGRF-42x18V	FL	150	110	3	70	176	212	248
FGRL-18x110C	FGRF-42x18V	FU	179	110	3	70	205	241	277
FGRL-18x110C	FGRF-42x18V	FV	260	110	3	70	286	322	358

FGRL-18x160C & FGRF-42x18V

Guide Rail Assembly

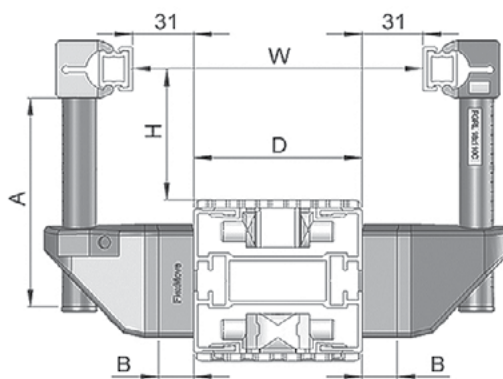

Note:
Plastic guide supports used for light products.

B Spacer = FGRD-18A

See pages 211 and 213 for components

Guide Rail	Guide Rail	Series	D (mm)	A (mm)	H (mm) Max	H (mm) Min	W (mm) B = 0	W (mm) B = 18	W (mm) B = 36
FGRL-18x160C	FGRF-42x18V	FK	45	160	3	135	71	107	143
FGRL-18x160C	FGRF-42x18V	FS	65	160	3	135	91	127	163
FGRL-18x160C	FGRF-42x18V	FM	85	160	3	130	111	147	183
FGRL-18x160C	FGRF-42x18V	FC	105	160	3	130	131	167	203
FGRL-18x160C	FGRF-42x18V	FL	150	160	3	130	176	212	248
FGRL-18x160C	FGRF-42x18V	FU	179	160	3	130	205	241	277
FGRL-18x160C	FGRF-42x18V	FV	260	160	3	130	286	322	358

FGRF-42x62-A110 & FGRK-18x80A Guide Rail Assembly

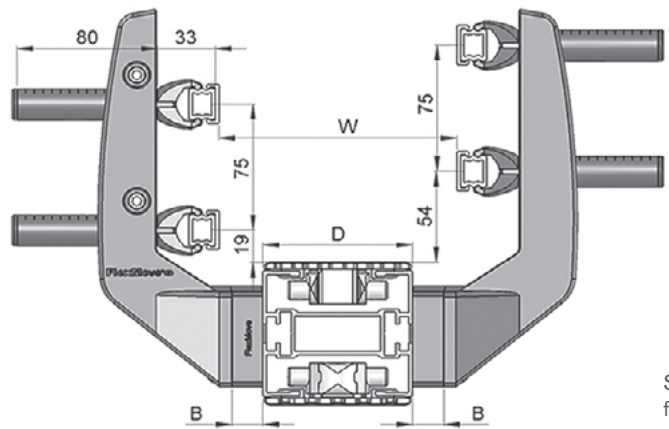

B Spacer = FGRD-18A

See pages 213 and 214 for components

Guide Rail	Guide Rail	Series	D (mm)	W min B = 0	W min B = 18	W min B = 36	W (mm) B = 0	W (mm) B = 18	W (mm) B = 36
FGRF-42x62-A110	FGRK-18x80A	FK	45	0	3	39	61	97	133
FGRF-42x62-A110	FGRK-18x80A	FS	65	0	23	59	81	117	153
FGRF-42x62-A110	FGRK-18x80A	FM	85	7	43	79	101	137	173
FGRF-42x62-A110	FGRK-18x80A	FC	105	27	63	99	121	157	193
FGRF-42x62-A110	FGRK-18x80A	FL	150	72	108	144	166	202	238
FGRF-42x62-A110	FGRK-18x80A	FU	179	101	137	173	195	231	267
FGRF-42x62-A110	FGRK-18x80A	FV	260	182	218	254	276	312	348

FGRF-42x62-A35 & FGRK-18x80A Guide Rail Assembly

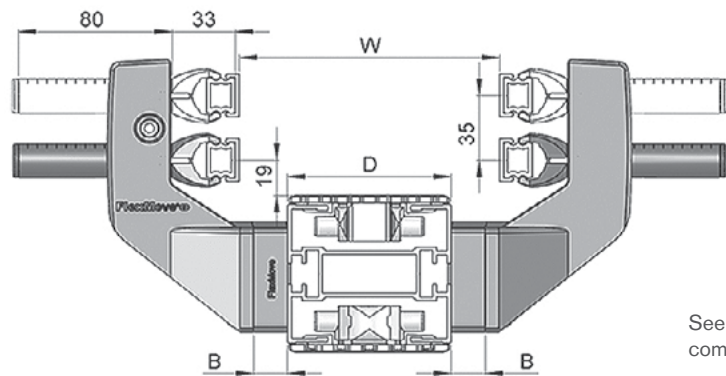

B Spacer = FGRD-18A

See pages 213 and 214 for components

Guide Rail	Guide Rail	Series	D (mm)	W min B = 0	W min B = 18	W min B = 36	W (mm) B = 0	W (mm) B = 18	W (mm) B = 36
FGRF-42x62-A35	FGRK-18x80A	FK	45	0	3	39	61	97	133
FGRF-42x62-A35	FGRK-18x80A	FS	65	0	23	59	81	117	153
FGRF-42x62-A35	FGRK-18x80A	FM	85	7	43	79	101	137	173
FGRF-42x62-A35	FGRK-18x80A	FC	105	27	63	99	121	157	193
FGRF-42x62-A35	FGRK-18x80A	FL	150	72	108	144	166	202	238
FGRF-42x62-A35	FGRK-18x80A	FU	179	101	137	173	195	231	267
FGRF-42x62-A35	FGRK-18x80A	FV	260	182	218	254	276	312	348

FGRF-42x18V & FGRK-18x80A
& FGRL18x110CA

FGRF-42x18V & FGRK-18x80A
& FGRL18x160CA

B Spacer = FGRD-18A

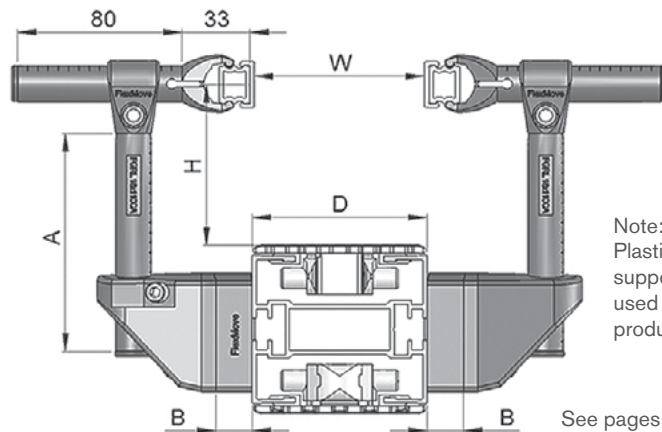

Note:
Plastic guide
supports
used for light
products.

See pages 212 and
213 for components

Guide Rail	Series	D (mm)	A = 110 H (mm) Min	A = 110 H (mm) Max	A = 160 H (mm) Min	A = 160 H (mm) Max	B (mm)	W (mm) Min	W (mm) Max
FGRL-18x110CA	FK	45	3	83	3	138	0	0	30
FGRL-18x110CA	FS	65	3	83	3	138	0	0	50
FGRL-18x110CA	FM	85	3	83	3	133	0	0	70
FGRL-18x110CA	FC	105	3	83	3	133	0	0	90
FGRL-18x110CA	FL	150	3	83	3	133	0	25	135
FGRL-18x110CA	FU	179	3	83	3	133	0	54	164
FGRL-18x110CA	FV	260	3	83	3	133	0	135	245
FGRL-18x110CA	FK	45	3	83	3	138	18	0	78
FGRL-18x110CA	FS	65	3	83	3	138	18	0	86
FGRL-18x110CA	FM	85	3	83	3	133	18	0	106
FGRL-18x110CA	FC	105	3	83	3	133	18	16	126
FGRL-18x110CA	FL	150	3	83	3	133	18	61	171
FGRL-18x110CA	FU	179	3	83	3	133	18	90	200
FGRL-18x110CA	FV	260	3	83	3	133	18	271	381
FGRL-18x110CA	FK	45	3	83	3	138	36	0	112
FGRL-18x110CA	FS	65	3	83	3	138	36	12	132
FGRL-18x110CA	FM	85	3	83	3	133	36	32	152
FGRL-18x110CA	FC	105	3	83	3	133	36	52	172
FGRL-18x110CA	FL	150	3	83	3	133	36	97	217
FGRL-18x110CA	FU	179	3	83	3	133	36	126	246
FGRL-18x110CA	FV	260	3	83	3	133	36	207	327
FGRL-18x110CA	FK	45	3	83	3	138	54	28	148
FGRL-18x110CA	FS	65	3	83	3	138	54	48	168
FGRL-18x110CA	FM	85	3	83	3	133	54	68	188
FGRL-18x110CA	FC	105	3	83	3	133	54	88	208
FGRL-18x110CA	FL	150	3	83	3	133	54	133	243
FGRL-18x110CA	FU	179	3	83	3	133	54	162	272
FGRL-18x110CA	FV	260	3	83	3	133	54	243	353

FGRF-42x18V FGRS-18 & FGDT-150 Guide Rail Assembly

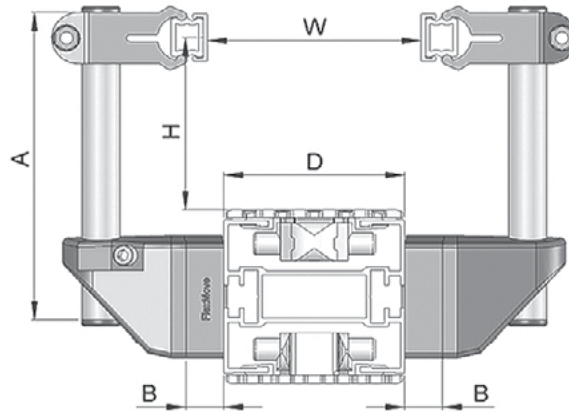

B Spacer = FGRD-18A

See pages 201, 210 and 213 for components

Guide Rail	Guide Rail	Series	D (mm)	A (mm)	H (mm) Min	H (mm) Max	W (mm) B = 0	W (mm) B = 18	W (mm) B = 36
FGRS-18	FGDT-150	FK	45	150	3	90	24	60	96
FGRS-18	FGDT-150	FS	65	150	3	90	44	80	116
FGRS-18	FGDT-150	FM	85	150	3	85	64	100	136
FGRS-18	FGDT-150	FC	105	150	3	85	84	120	156
FGRS-18	FGDT-150	FL	150	150	3	85	129	165	201
FGRS-18	FGDT-150	FU	179	150	3	85	158	194	230
FGRS-18	FGDT-150	FV	260	150	3	85	239	275	311

FGRF-42x18V FGRS-18 & FGDT-200 Guide Rail Assembly

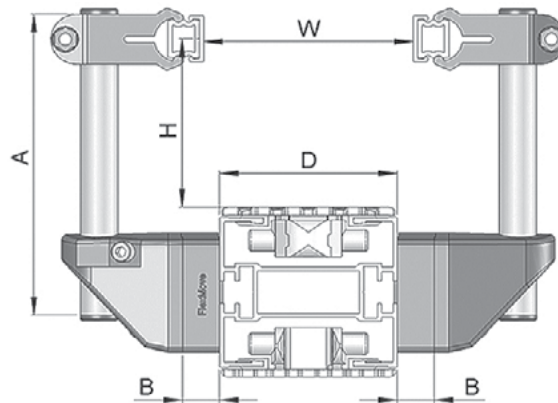

B Spacer = FGRD-18A

See pages 201, 210 and 213 for components

Guide Rail	Guide Rail	Series	D (mm)	A (mm)	H (mm) Min	H (mm) Max	W (mm) B = 0	W (mm) B = 18	W (mm) B = 36
FGRS-18	FGDT-200	FK	45	200	3	140	24	60	96
FGRS-18	FGDT-200	FS	65	200	3	140	44	80	116
FGRS-18	FGDT-200	FM	85	200	3	135	64	100	136
FGRS-18	FGDT-200	FC	105	200	3	135	84	120	156
FGRS-18	FGDT-200	FL	150	200	3	135	129	165	201
FGRS-18	FGDT-200	FU	179	200	3	135	158	194	230
FGRS-18	FGDT-200	FV	260	200	3	135	239	275	311

FGRB-40x18 & FGRK-18x80

Guide Rail Assembly

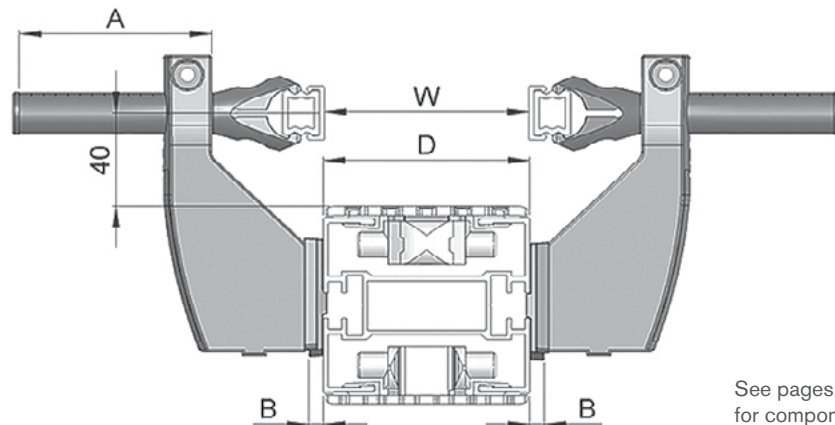

B Spacer = FGRD-6B

See pages 212 and 212
for components

Guide Rail	Guide Rail	Series	A (mm)	B (mm)	D (mm)	W (mm) Min	W (mm) Max
FGRB-40x18	FGRK-18x80	FK	80	0	45	0	55
FGRB-40x18	FGRK-18x80	FS	80	0	65	0	75
FGRB-40x18	FGRK-18x80	FM	80	0	85	0	95
FGRB-40x18	FGRK-18x80	FC	80	0	105	15	115
FGRB-40x18	FGRK-18x80	FL	80	0	150	60	160
FGRB-40x18	FGRK-18x80	FU	80	0	179	89	189
FGRB-40x18	FGRK-18x80	FV	80	0	260	170	270
FGRB-40x18	FGRK-18x80	FK	45	6	45	0	67
FGRB-40x18	FGRK-18x80	FS	65	6	65	0	87
FGRB-40x18	FGRK-18x80	FM	85	6	85	7	107
FGRB-40x18	FGRK-18x80	FC	105	6	105	27	127
FGRB-40x18	FGRK-18x80	FL	150	6	150	72	172
FGRB-40x18	FGRK-18x80	FU	179	6	179	101	201
FGRB-40x18	FGRK-18x80	FV	260	6	260	182	282
FGRB-40x18	FGRK-18x80	FK	45	12	45	0	79
FGRB-40x18	FGRK-18x80	FS	65	12	65	0	99
FGRB-40x18	FGRK-18x80	FM	85	12	85	19	119
FGRB-40x18	FGRK-18x80	FC	105	12	105	39	139
FGRB-40x18	FGRK-18x80	FL	150	12	150	84	184
FGRB-40x18	FGRK-18x80	FU	179	12	179	113	213
FGRB-40x18	FGRK-18x80	FV	260	12	260	194	294
FGRB-40x18	FGRK-18x80	FK	45	18	45	1	91
FGRB-40x18	FGRK-18x80	FS	65	18	65	21	111
FGRB-40x18	FGRK-18x80	FM	85	18	85	31	131
FGRB-40x18	FGRK-18x80	FC	105	18	105	51	151
FGRB-40x18	FGRK-18x80	FL	150	18	150	96	196
FGRB-40x18	FGRK-18x80	FU	179	18	179	125	225
FGRB-40x18	FGRK-18x80	FV	260	18	260	206	306

Bottling Guide Rail Assembly

Bottles Handling

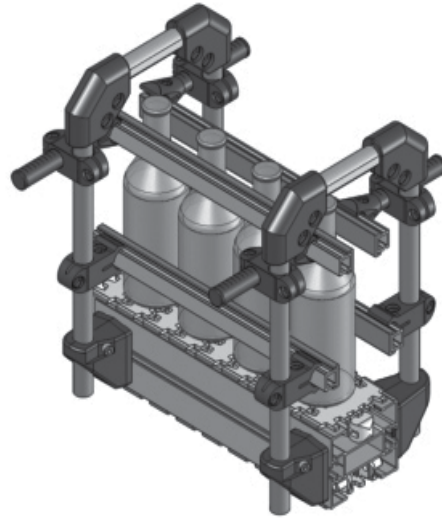
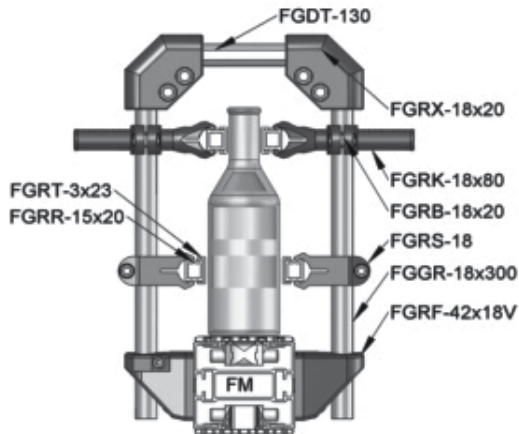

Double Track Guide Rail Assembly

Cans Handling

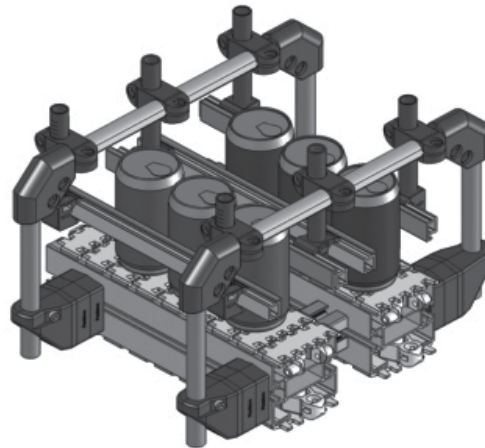
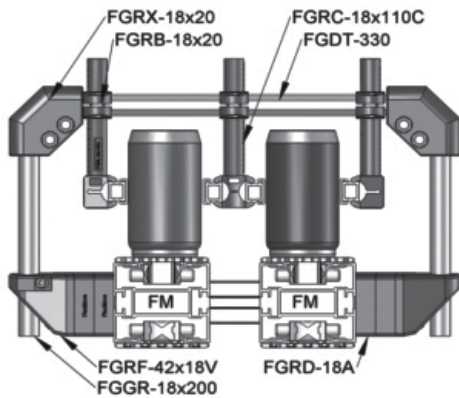

Duo-Layer Guide Rail Assembly

Box Handling

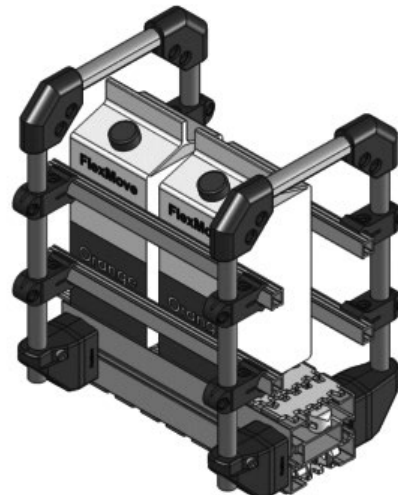
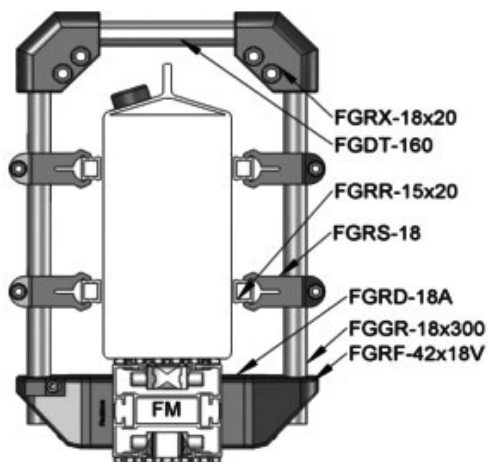

Extra Bottom Guide Rail Assembly Carton Box Handling

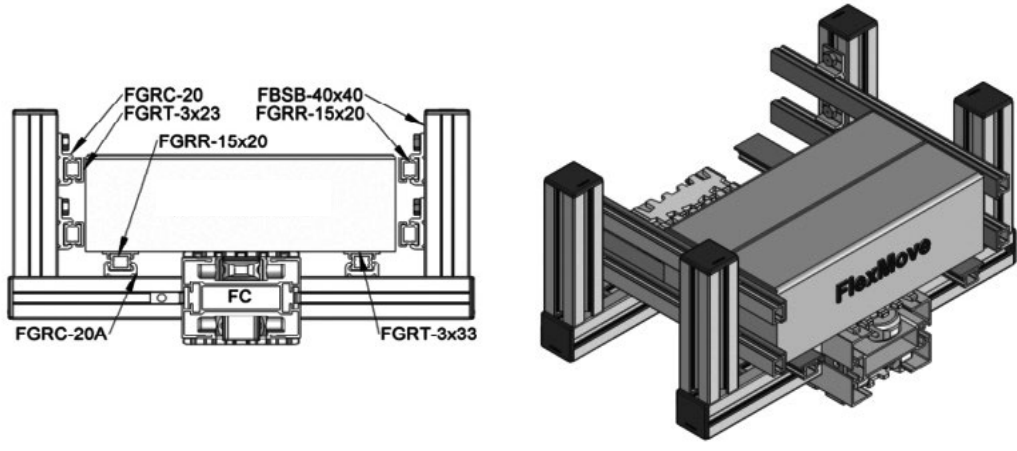

Width Adjustment Guide Rail Assembly Packaging Box Handling

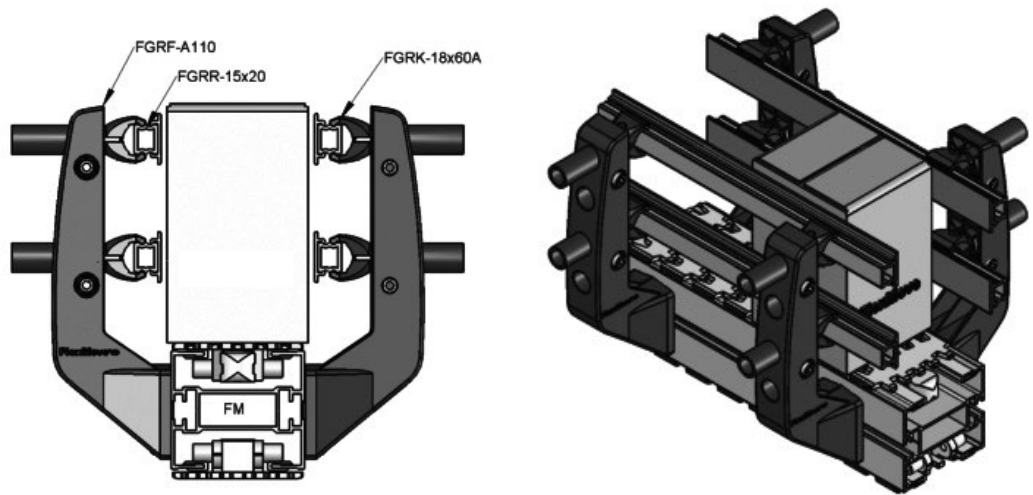

Width Adjustment Guide Rail Assembly Container Handling

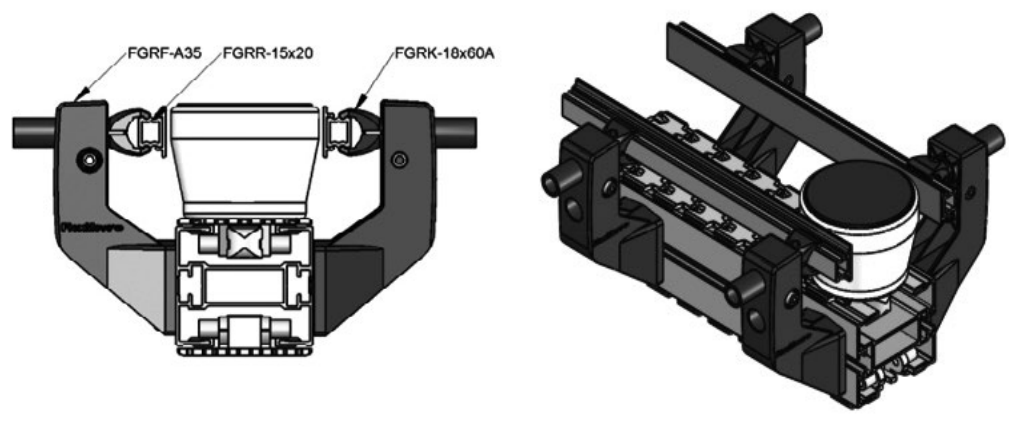

Width & Height Adjustable Guide Rail Assembly

Box Handling

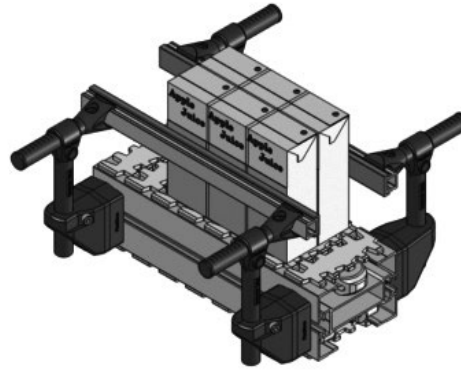
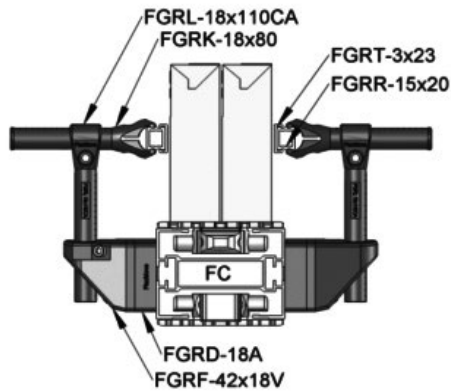

Width & Height Adjustable Guide Rail Assembly

Cans Handling

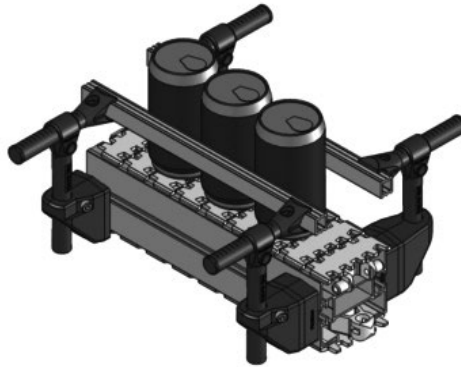
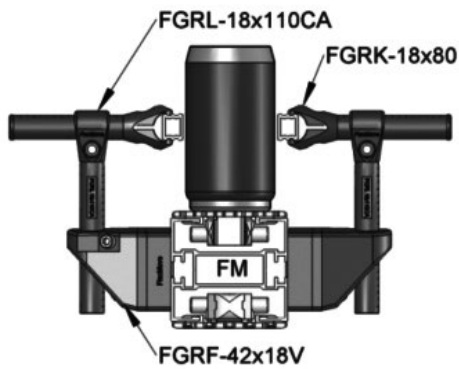

Width & Height Adjustable Guide Rail Assembly

Pucks Handling

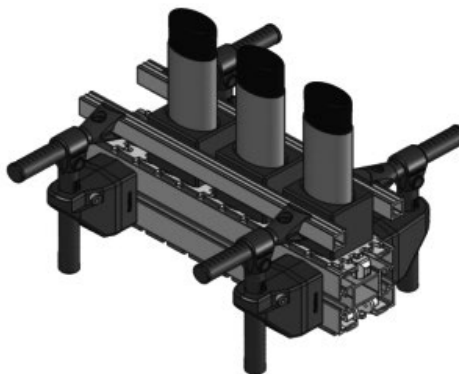
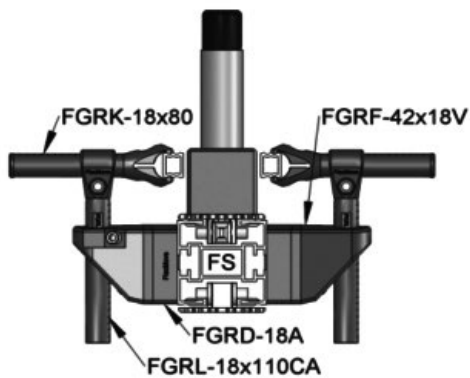

Pallet Assembly Line Guide Rail

Electronic Assembly Handling

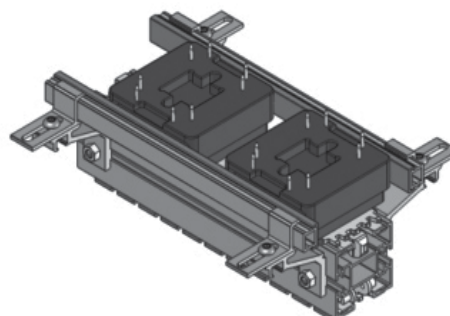
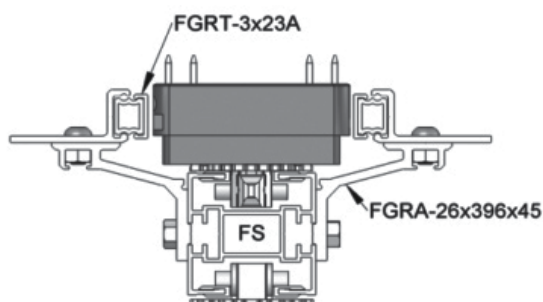

Cassette Guide Rail Assembly

Disc Drive Cassette Handling

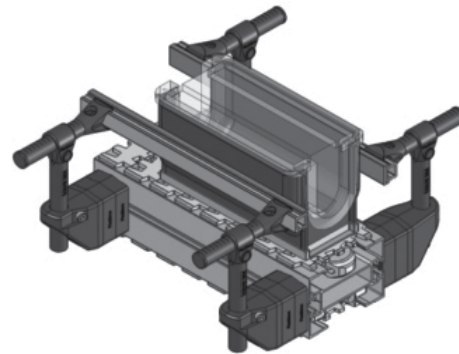
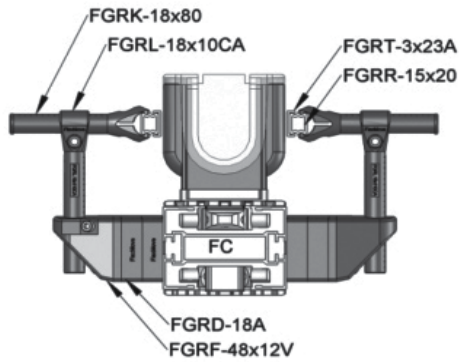

Width Adjustable Guide Rail Assembly

Box Handling

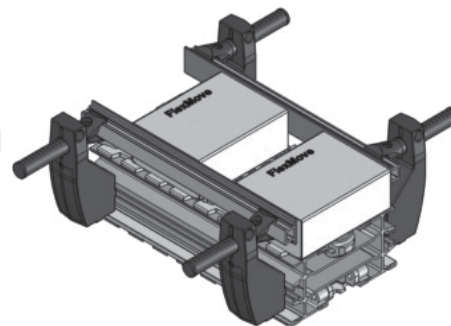
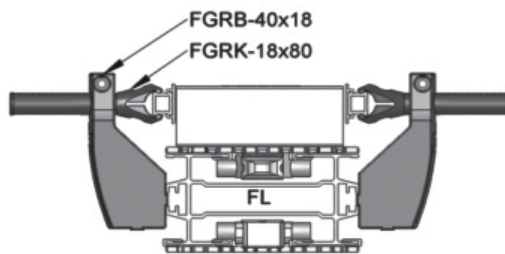

Width & Height Adjustable Guide Rail Assembly

Packaging Box Handling

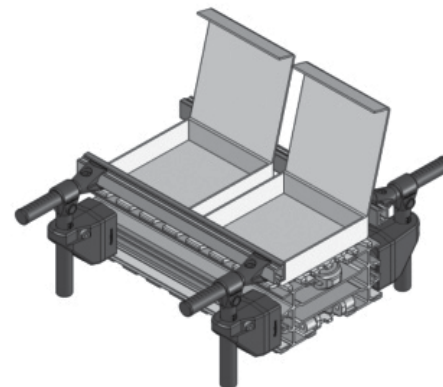
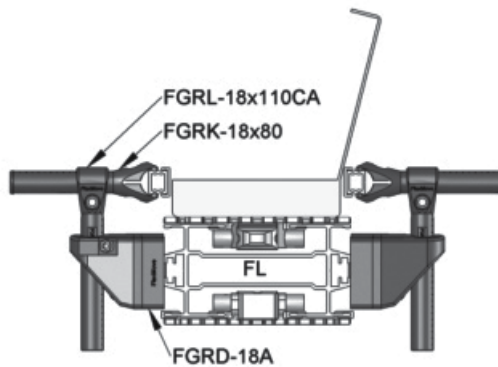

Width & Height Guide Rail Assembly

Paper Converting Handling

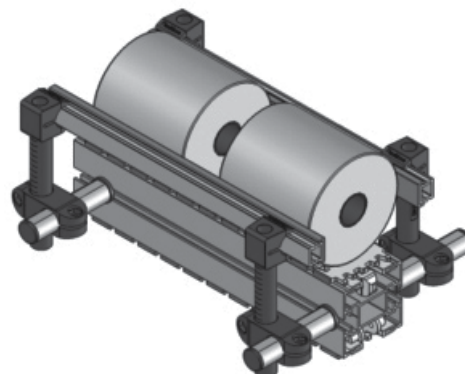
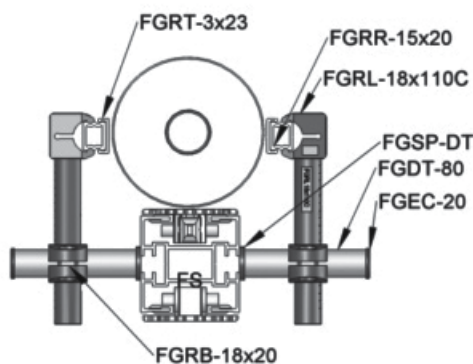

Small Box Guide Rail Assembly

Small Box Handling

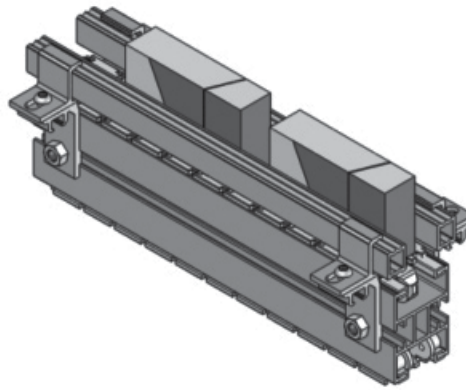
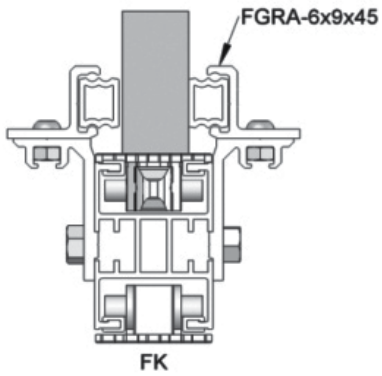

Twin Track Pallet Guide Rail Assembly

Pallet Handling

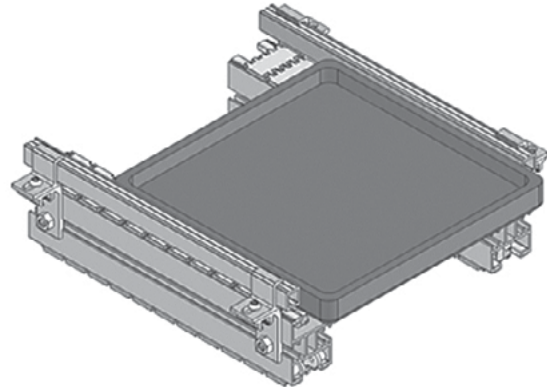
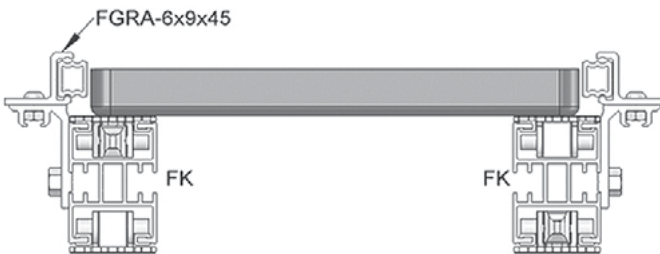

FGVG-3

Special V Guide - Aluminum

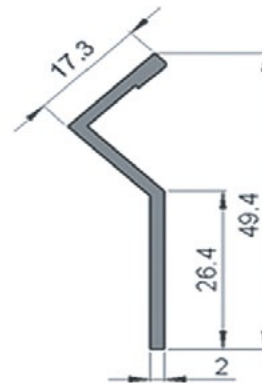
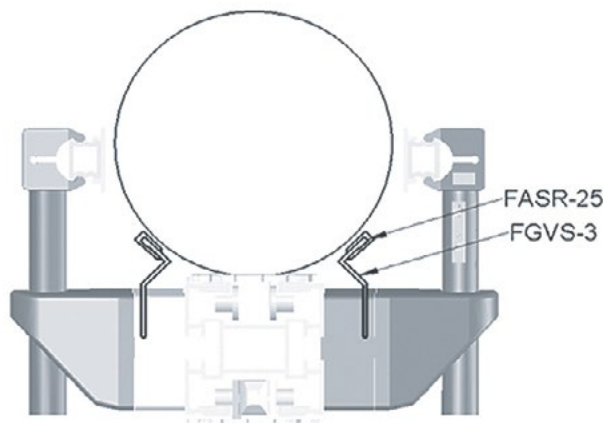

UOM: 3 meter / length

FGDT-70	Distance Tube, L = 70 mm - Aluminum
FGDT-80	Distance Tube, L = 80 mm - Aluminum
FGDT-100	Distance Tube, L = 100 mm - Aluminum
FGDT-150	Distance Tube, L = 150 mm - Aluminum
FGDT-200	Distance Tube, L = 200 mm - Aluminum
FGDT-250	Distance Tube, L = 250 mm - Aluminum

UOM: 10 pcs / pk

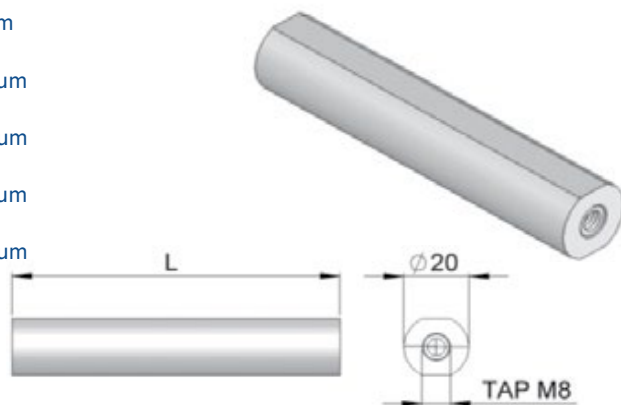

FGGR-18X100	18mm Tube, L = 100 mm - Aluminum
FGGR-18X150	18mm Tube, L = 150 mm - Aluminum
FGGR-18X200	18mm Tube, L = 200 mm - Aluminum
FGGR-18X250	18mm Tube, L = 250 mm - Aluminum
FGGR-18X300	18mm Tube, L = 300 mm - Aluminum

UOM: 10 pcs / pk

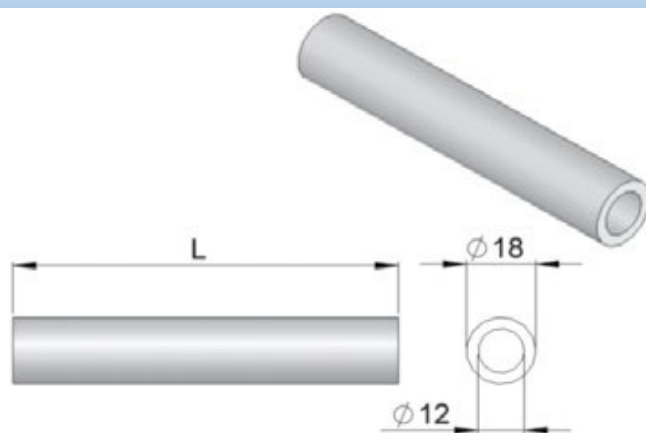

FGEC-18	End cap. 18 mm Tube - Polyamide	FGEC-20	End cap , Distance Tube - Polyamide
---------	---------------------------------	---------	-------------------------------------

UOM: 10 pcs / pk

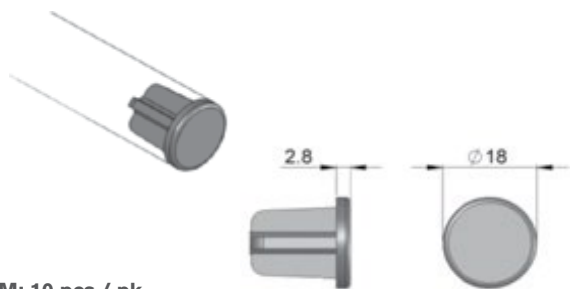

UOM: 10 pcs / pk

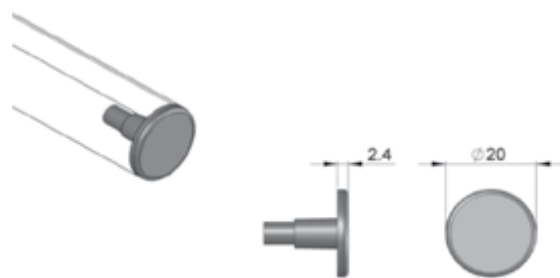

FGAP-25	Spring Pin - Steel	FGRA-26x39x45A	Bracket for sensor - Aluminum
---------	--------------------	----------------	-------------------------------

UOM: 50pcs / pk

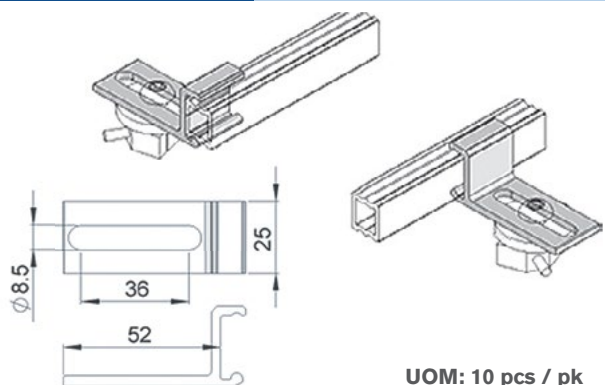
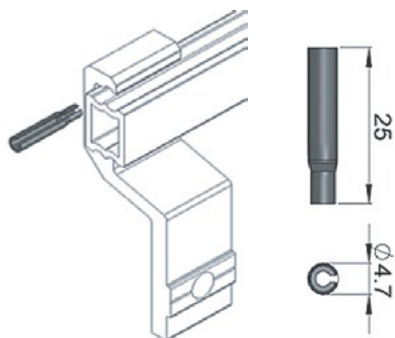

UOM: 10 pcs / pk

FGRA-8x39x45 Adjustable Guide Rail Bracket - Aluminum

Including spring pin, M6 screw & Nut

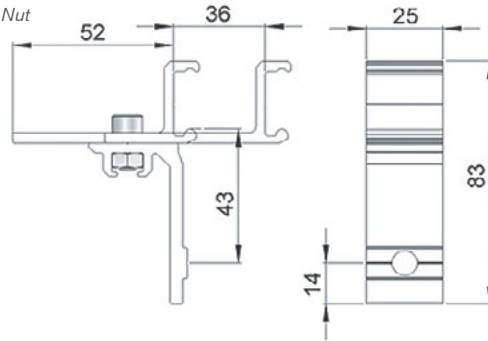
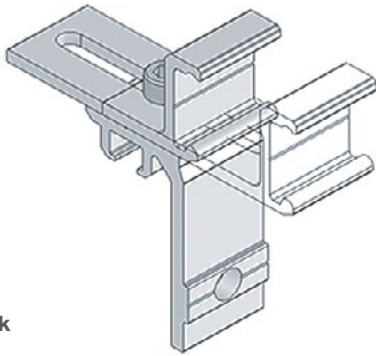

UOM: 10 pcs / pk

Mounting to beam : FATB-20 (1) , FALN-M8 (1) , FAFW-M8 (1)

FGRA-8x9x45 Adjustable Guide Rail Bracket - Aluminum

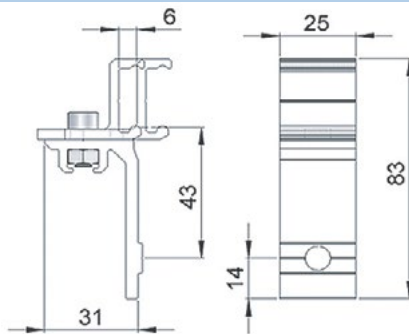
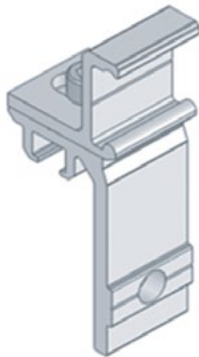

UOM: 10 pcs / pk

Mounting to beam : FATB-20 (1) , FALN-M8 (1) , FAFW-M8 (1)

FGRA-26x39x45 Adjustable Guide Rail Bracket - Aluminum

Including spring pin, M8 screw & nut

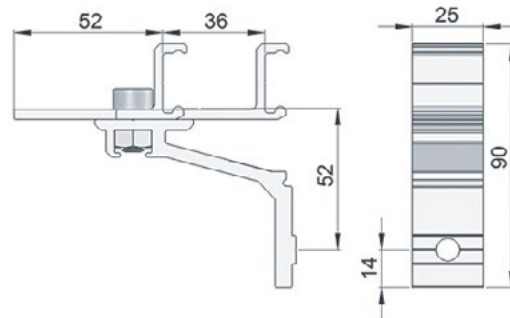
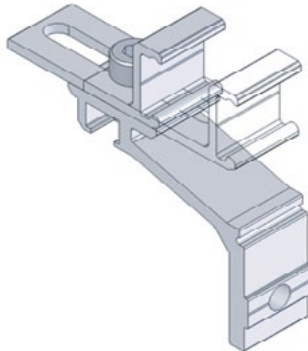

UOM: 10 pcs / pk

Mounting to beam : FATB-20 (1) , FALN-M8 (1) , FAFW-M8 (1)

FGRA-26x9x45 Adjustable Guide Rail Bracket - Aluminum

Including spring pin, M8 screw & nut

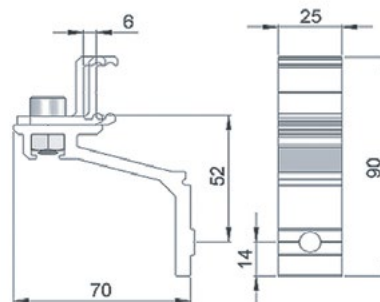
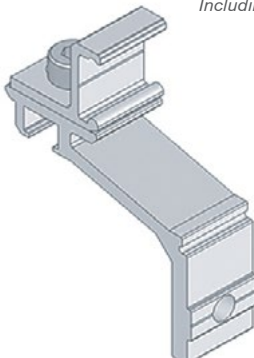

UOM: 10 pcs / pk

Mounting to beam : FATB-20 (1) , FALN-M8 (1) , FAFW-M8 (1)

FGRB-16x54

Fixed Guide Rail Bracket - Aluminum

Including spring pin.

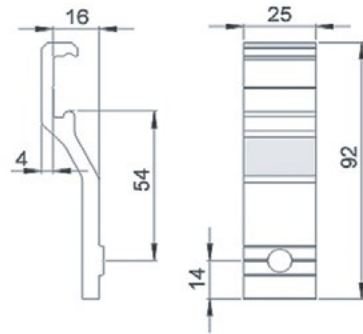
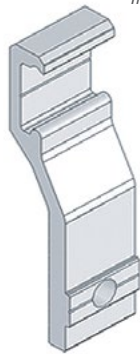

UOM: 10 pcs / pk

Mounting to beam : FATB-20 (1) , FALN-M8 (1) , FAFW-M8 (1)

FGRB-16x42

Fixed Guide Rail Bracket - Aluminum

Including spring pin.

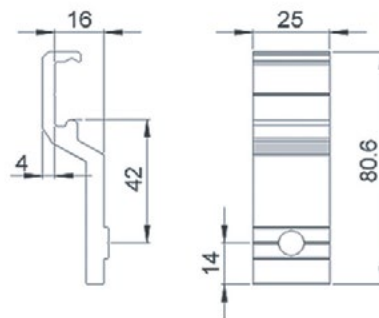
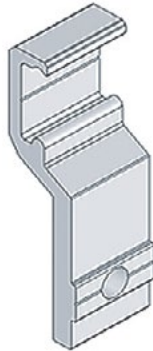

UOM: 10 pcs / pk

Mounting to beam : FATB-20 (1) , FALN-M8 (1) , FAFW-M8 (1)

FGRB-28x42

Fixed Guide Rail Bracket - Aluminum

Including spring pin.

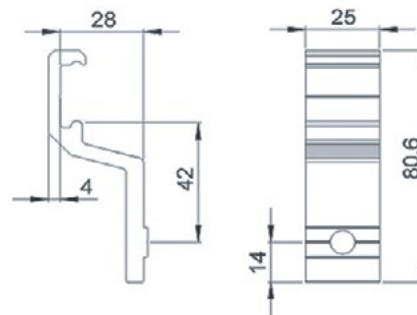
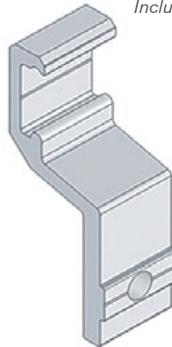

UOM: 10 pcs / pk

Mounting to beam : FATB-20 (1) , FALN-M8 (1) , FAFW-M8 (1)

FGRB-40x42

Fixed Guide Rail Bracket - Aluminum

Including spring pin.

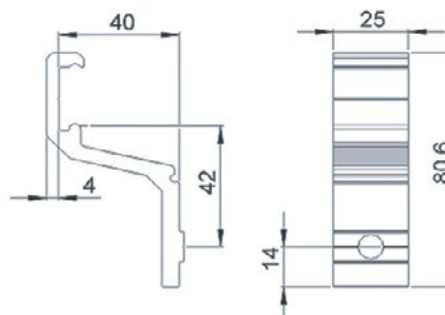
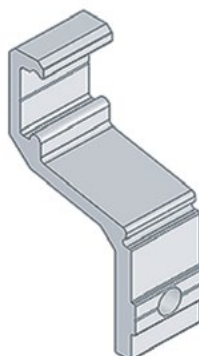

UOM: 10 pcs / pk

Mounting to beam : FATB-20 (1) , FALN-M8 (1) , FAFW-M8 (1)

FGRB-49x42

Fixed Guide Rail Bracket - Aluminum

Including spring pin.

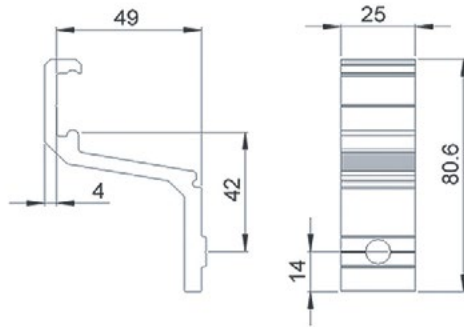
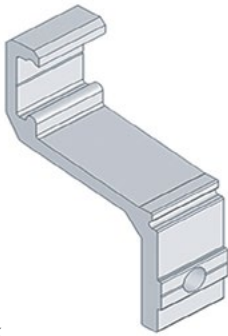

UOM: 10 pcs / pk

Mounting to beam : FATB-20 (1) , FALN-M8 (1) , FAFW-M8 (1)

FGRB-53x42

Fixed Guide Rail Bracket - Aluminum

Including spring pin.

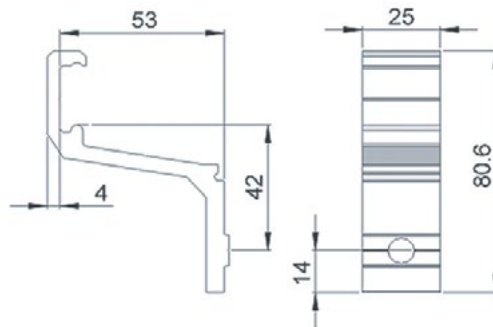
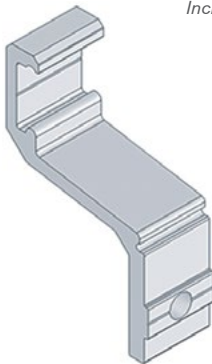

UOM: 10 pcs / pk

Mounting to beam : FATB-20 (1) , FALN-M8 (1) , FAFW-M8 (1)

FGRB-90x42

Fixed Guide Rail Bracket - Aluminum

Including spring pin.

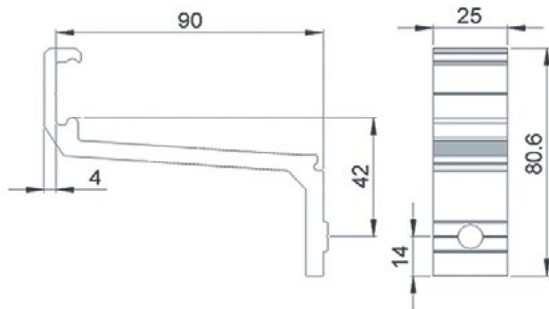
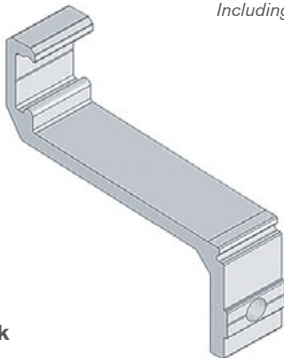

UOM: 10 pcs / pk

Mounting to beam : FATB-20 (1) , FALN-M8 (1) , FAFW-M8 (1)

FGRD-6

Guide Rail Bracket Spacer - Aluminum

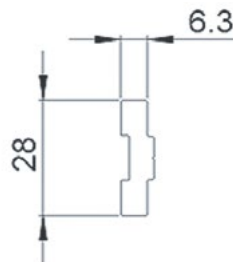
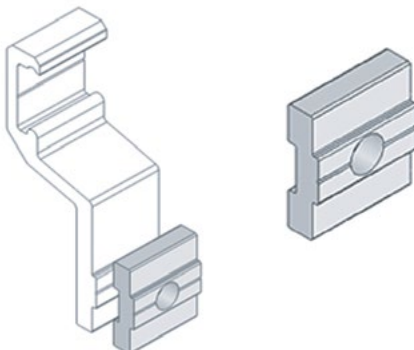

UOM: 10 pcs / pk

FGRD-6B

Spacer for FGRB-40x ## - Polyamide (## = Diameter in mm)

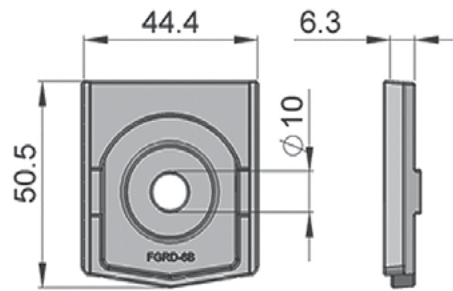
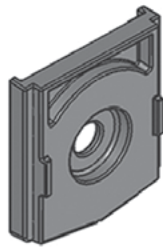

UOM: 10 pcs / pk

For use with guide rail bracket support:
 FGRB - 40 x 18 / 20
 FGRB - 40 x 15 x 20

FGRC-20

Guide Rail Support - Aluminum

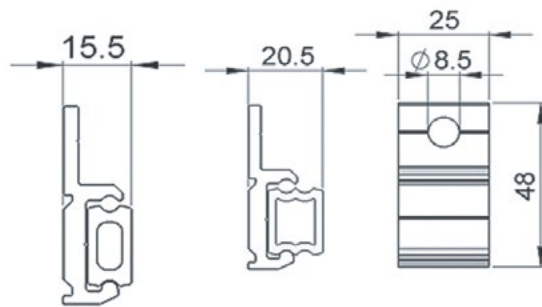
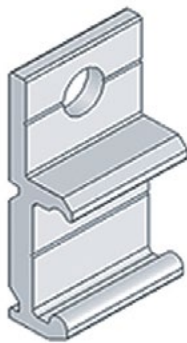

UOM: 10 pcs / pk

Mounting: FAHB-M8 x 12 (1), FASN-M8 (1), FAFW-M8 (1)

FGRC-20A

Guide Rail Support - Aluminum

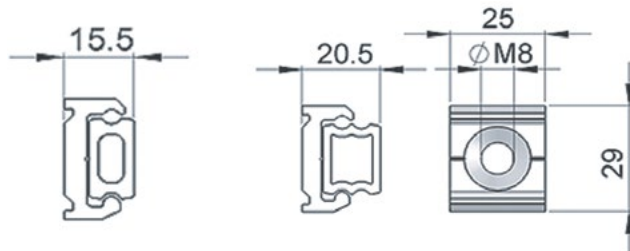
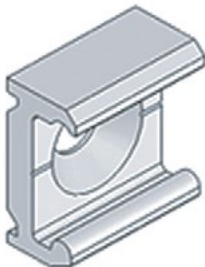

UOM: 10 pcs / pk

Mounting: C'SUNK M8 x 12

FGRB-16x42C

Guide Rail Bracket - Polyamide

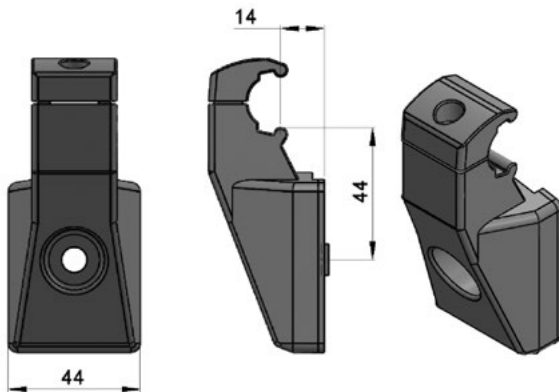

UOM: 10pcs / pk

FGRB-16x52C

Guide Rail Bracket - Polyamide

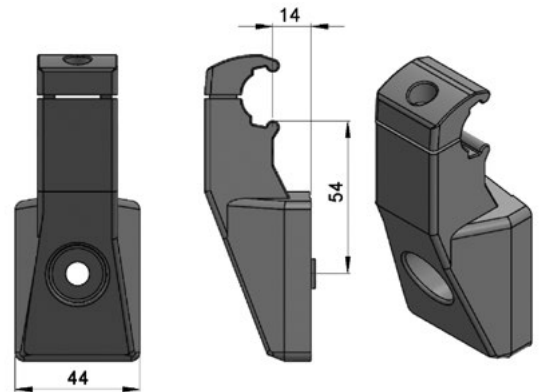

UOM: 10pcs / pk

FGRR-15x20

Guide Rail Rectangular, 15mm x 20 mm - Aluminum

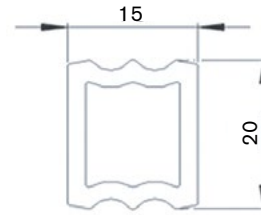
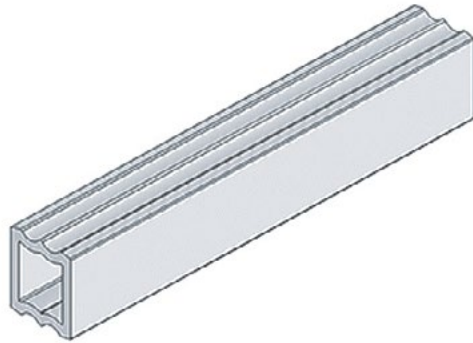

UOM: 3 meter / length

FGRR-10x20

Guide Rail Rectangular, 10 mm x 20 mm - Aluminum

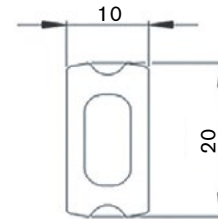
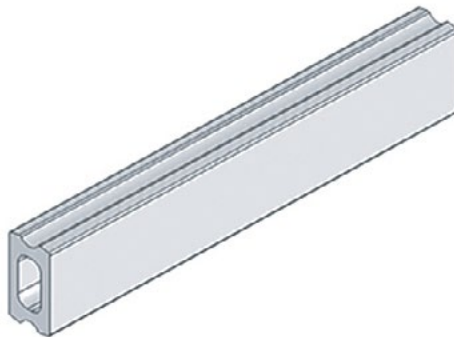

UOM: 3 meter / length

FGRR-10x20F

Guide Rail Rectangular, 10 mm x 20 mm Type F - Aluminum

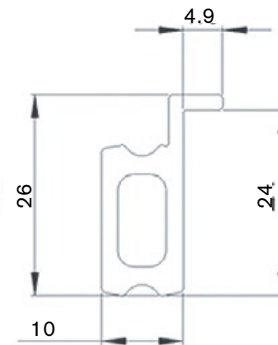
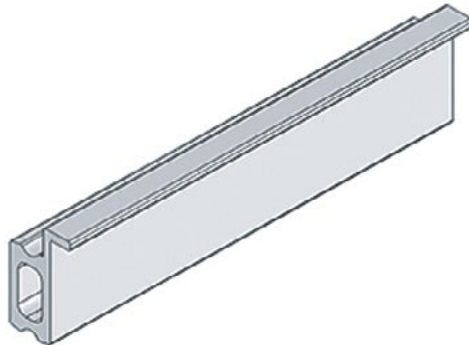

UOM: 3 meter / length

FGRR-15X20P

Guide Rail Rectangular, 15mm x 20 mm – HDPE

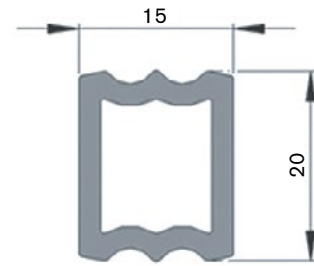
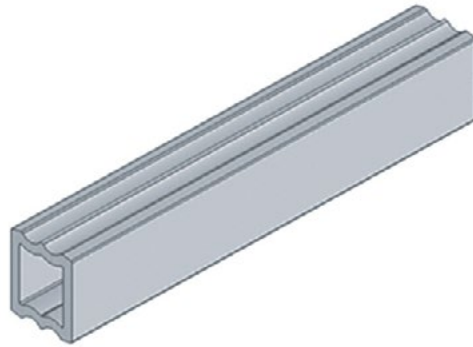

UOM: 3 meter / length

FGRT-3x23

Guide Rail Cover - HDPE

FGRT-3x23A

Guide Rail Cover – HDPE (Conductive)

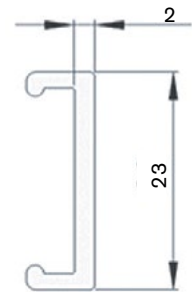
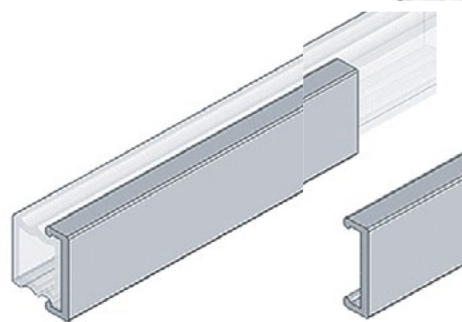

UOM: 3 meter / length

FGRT-3x33

Guide Rail Cover - HDPE

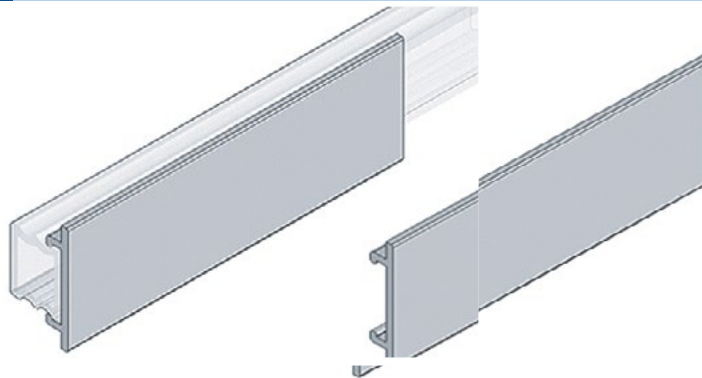

UOM: 3 meter / length

FGRT-3x50

Guide Rail Cover - HDPE

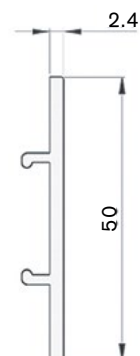
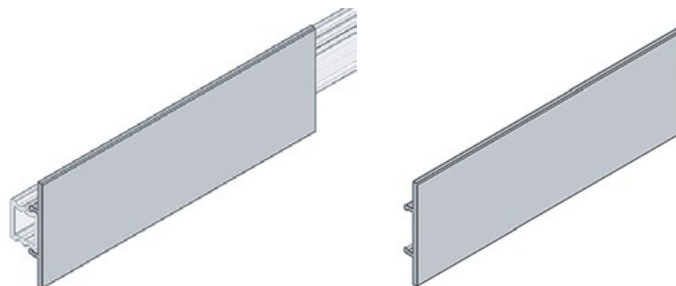

UOM: 3 meter / length

FGRR-15x40

Guide Rail Rectangular, 15mm x 40 mm – Aluminum

UOM: 3 meter / length

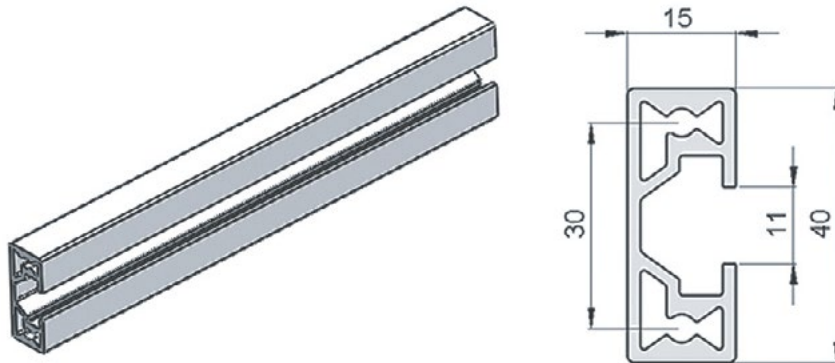

FGEC-15x40

End Cap for FGRR-15x40 - Polyamide

UOM: 10pcs / pk

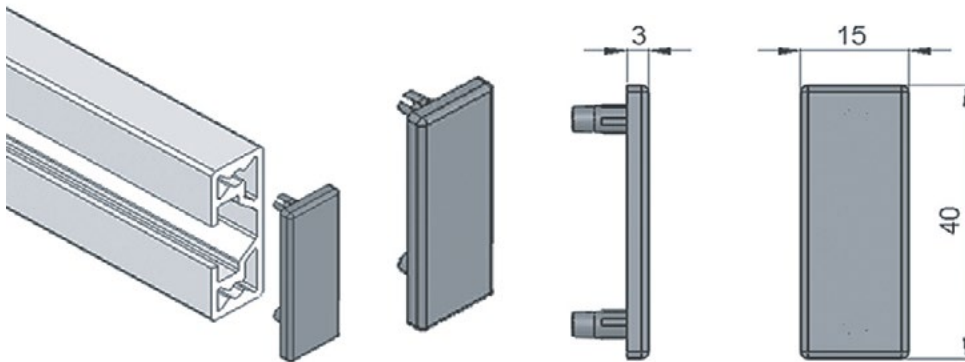

FGRA-22HD

Guide Rail Support Assembly, Heavy Duty

UOM: pc

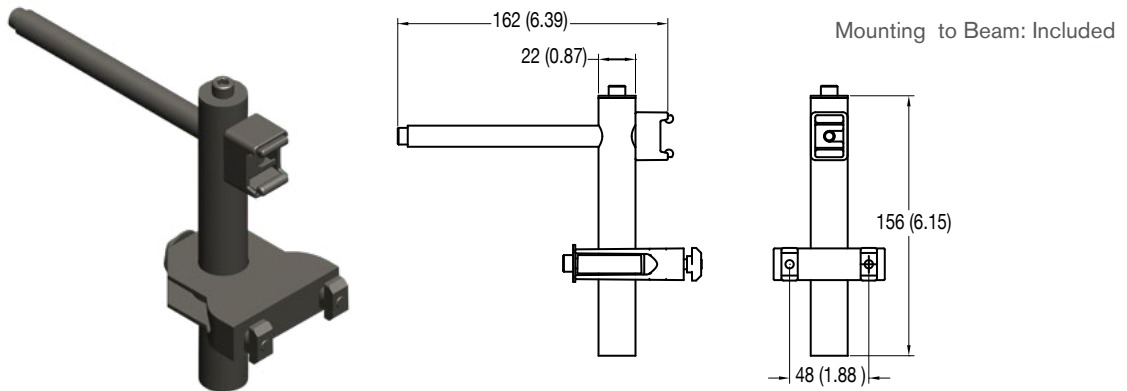

FGRA-22HDT

Guide Rail Support Assembly, Toolless, Heavy Duty

UOM: pc

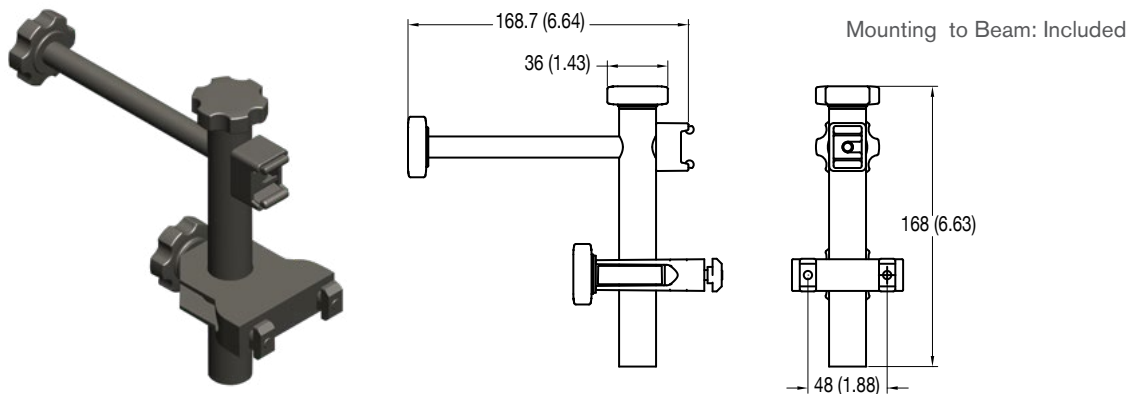

FGEC-15x20

End Cap for FGRR-15x20 - Polyamide

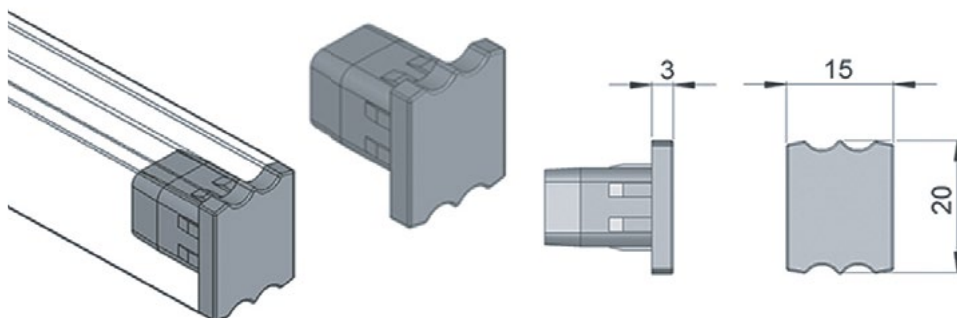

UOM: 10pcs / pk

FGRC-100

Rail Connecting – Aluminum L = 100 mm , B = 50 mm

FGRC-60

Rail Connecting – Aluminum L = 60 mm , B = 30 mm

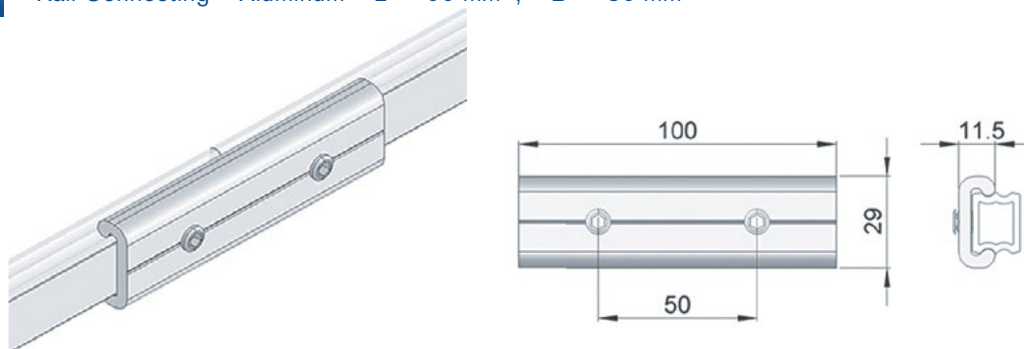

UOM: 10pcs / pk

FGEC-10x20

End Cap for FGRR-10x20 & FGRR10x20F - Polyamide

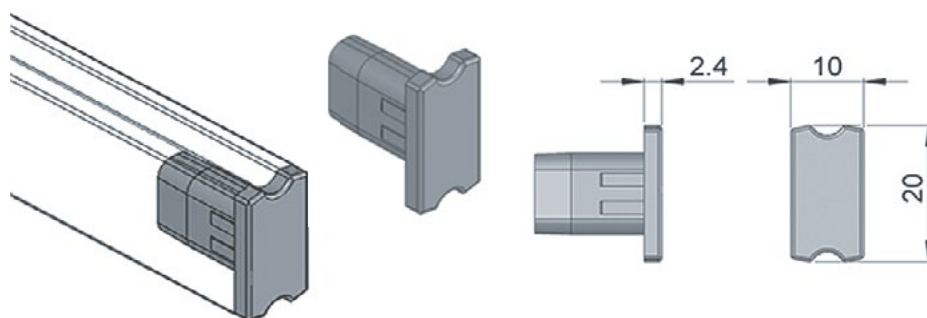

UOM: 10pcs / pk

FGRJ-15x20

Connecting Plug for FGRR-15x20 - Polyamide

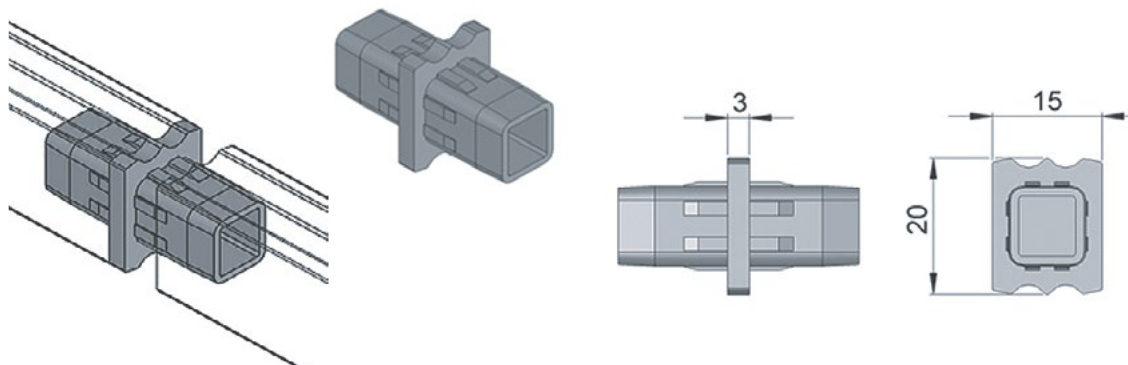

UOM: 10pcs / pk

FGRJ-10x20

Connecting Plug for FGRR-10x20 & FGRR-10x20F - Polyamide

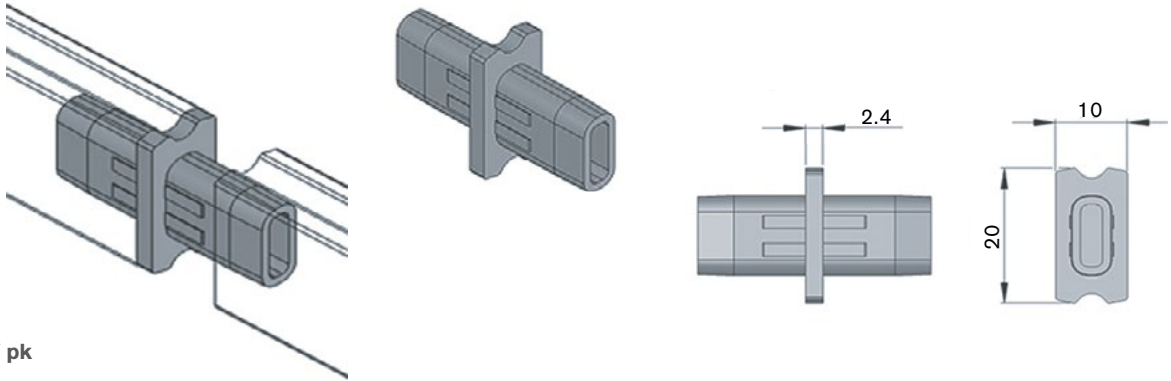

UOM: 10pcs / pk

FGEC-30D

30° End Cap for FGRR-15x20 - Polyamide

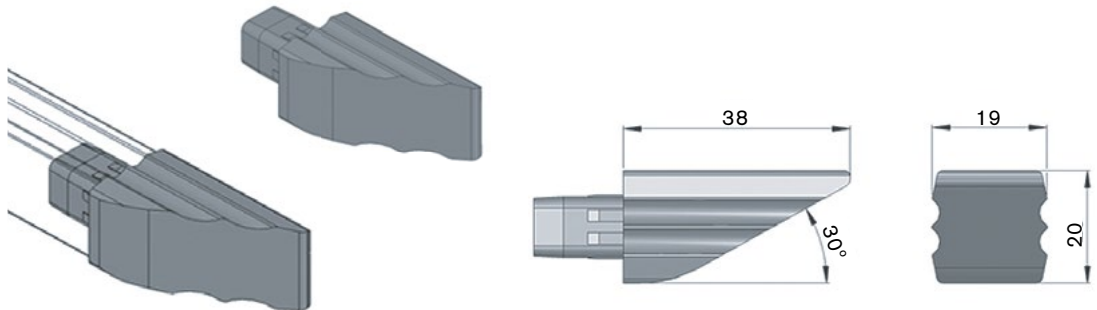

UOM: 10pcs / pk

FGRS-18

Guide Rail Support - Polyamide

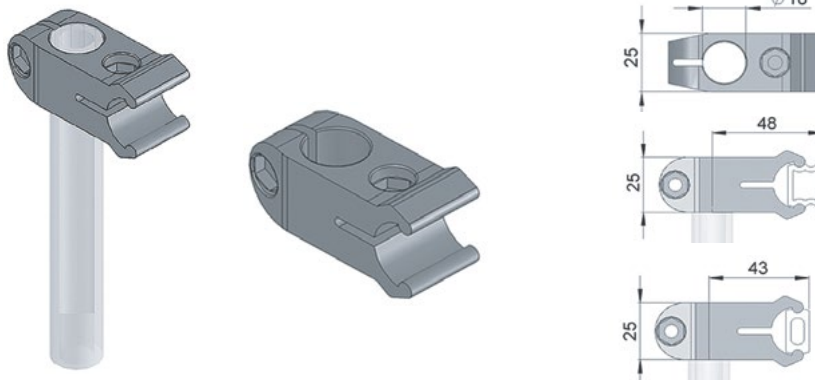

UOM: 10pcs / pk

FGRS-15x20

Guide Rail Support - Polyamide

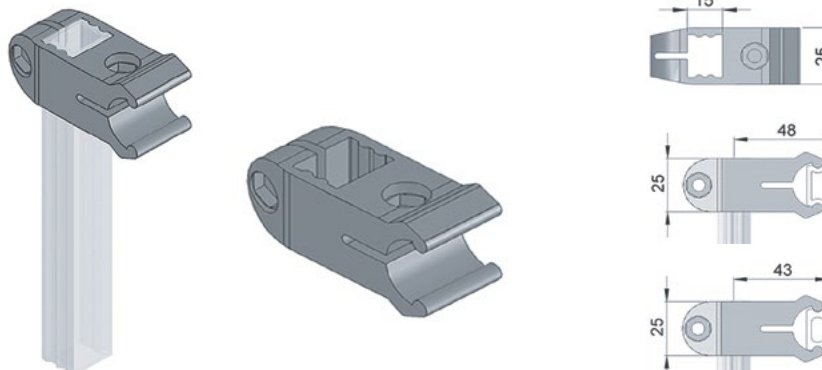

UOM: 10pcs / pk

FGRL-18x110C

Guide Rail Support, L = 110 mm - Polyamide

FGRL-18x160C

Guide Rail Support, L = 160 mm - Polyamide

UOM: 10pcs / pk

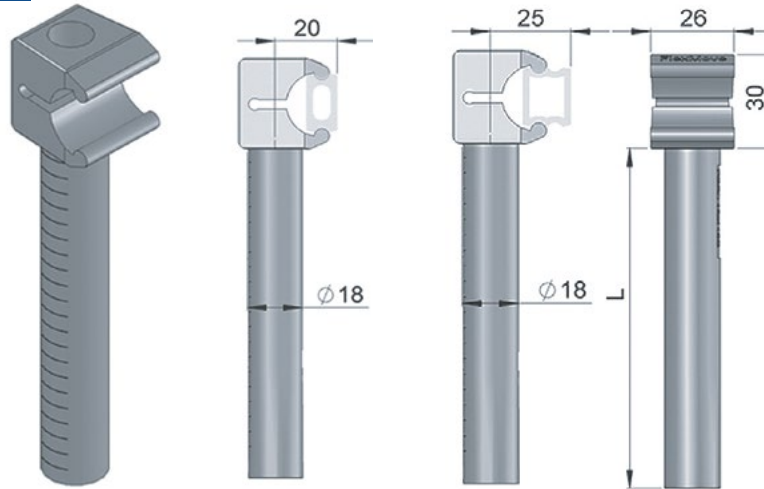

Note:
Plastic guide supports
used for light products.

To be used directly with guide rail
bracket support FGRF- 42 x 18V
or FGRB-18 x 20

FGRC-18x110C

Double Guide Rail Support, L = 110 mm - Polyamide

FGRC-18x160C

Double Guide Rail Support, L = 160 mm - Polyamide

UOM: 10pcs / pk

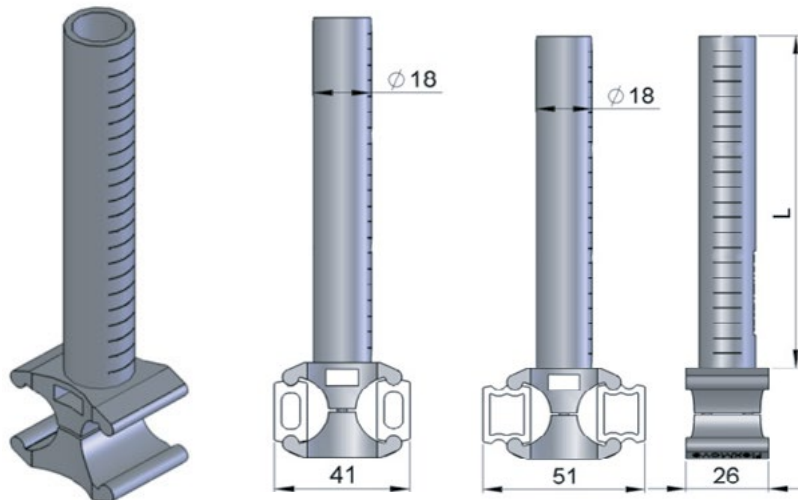

Note:
Plastic guide supports
used for light products.

Suitable for use with cross
connector FGRB-18 x18 and
a crossing 18 mm aluminum
tube above the double track.

FGRK-18x40A Guide Rail Support, L = 40 mm - Polyamide

FGRK-18x60A Guide Rail Support, L = 60 mm - Polyamide

FGRK-18x80A Guide Rail Support, L = 80 mm - Polyamide

FGRK-18x130A Guide Rail Support, L = 130 mm - Polyamide

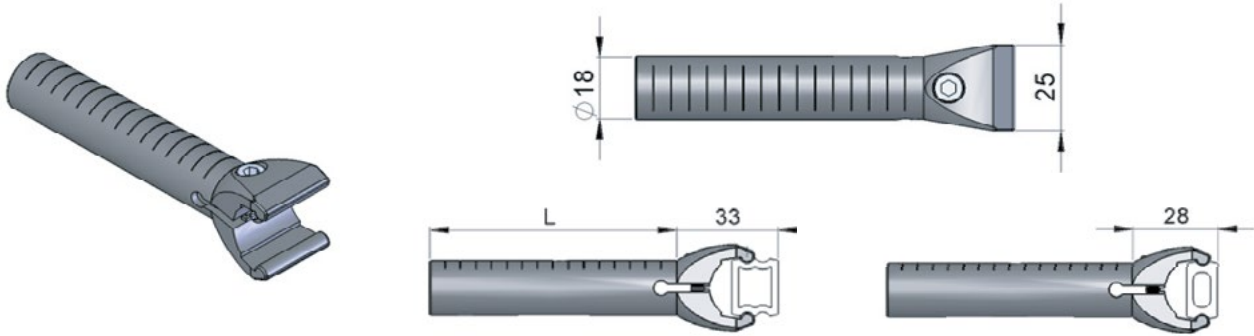

UOM: 10pcs / pk

Suitable for use with cross connector FGRB-18 x18 and FGRF – 42 x 18V

FGRL-18x110CA Guide Rail Support, L = 110 mm - Polyamide

FGRL-18x160CA Guide Rail Support, L = 160 mm - Polyamide

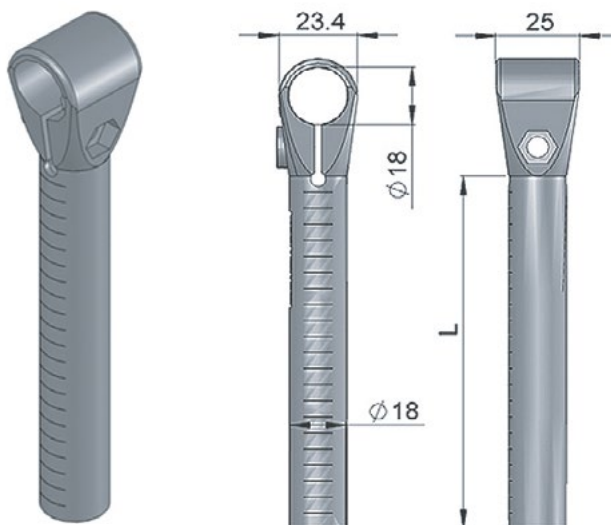

UOM: 10pcs / pk

Note:
Plastic guide supports
used for light products.

Suitable for use with cross connector FGRK –
18 x 80 / 130 / 40A / 60A / 80A /130A

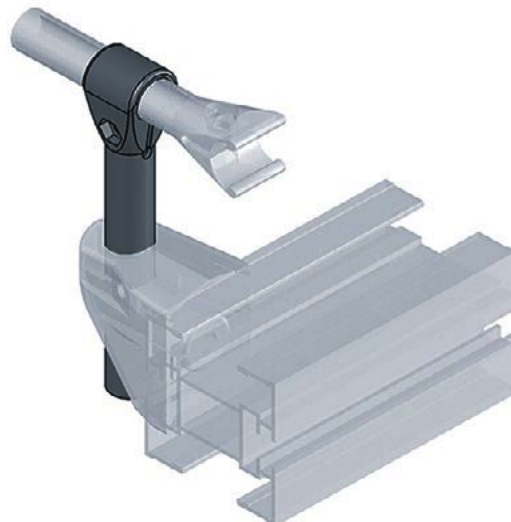

FGRF-42x18V

Guide Rail Bracket – Polyamide

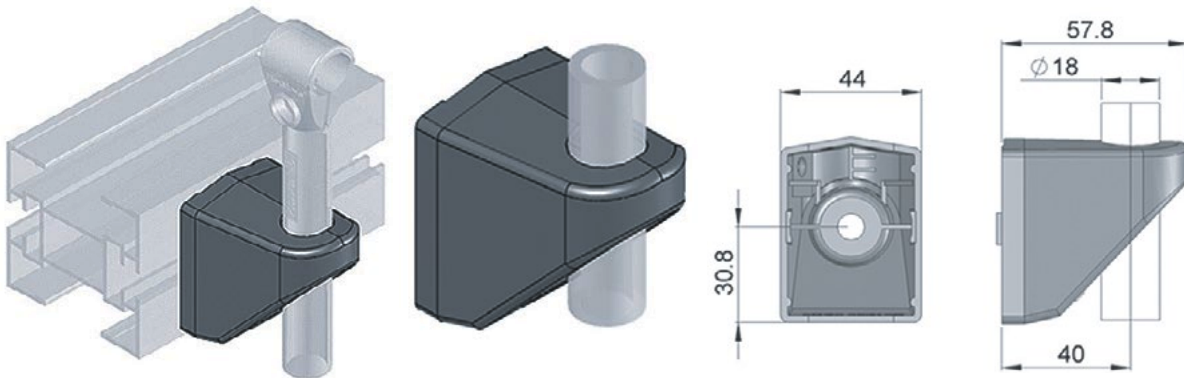

UOM: 10pcs / pk

To be used with :

- FGGR - 18 x * 100
- FGRL - 18 x 110C / 160C
- FGRC - 18 x 110C / 160C

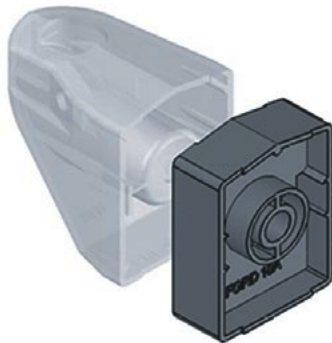

For use with guide rail bracket support FGRF -42 x 18V

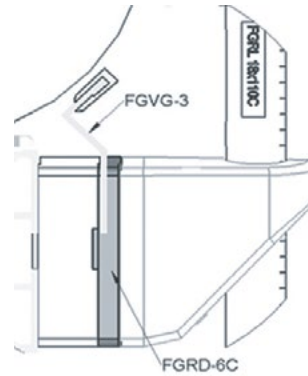

FGRD-18A

Spacer for FGRF-42x18V - Polyamide

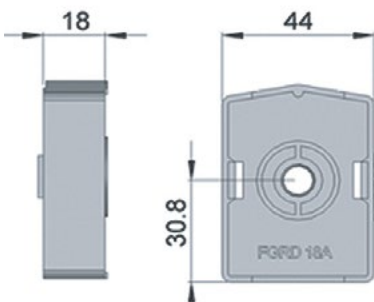

UOM: 10pcs / pk

FGRD-6A

Spacer for FGRF-42x18V - Polyamide

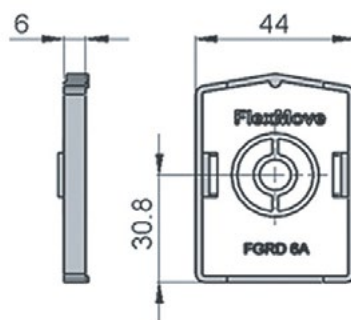

UOM: 10pcs / pk

FGRD-6C

Spacer for FGRF-42x18V - Polyamide

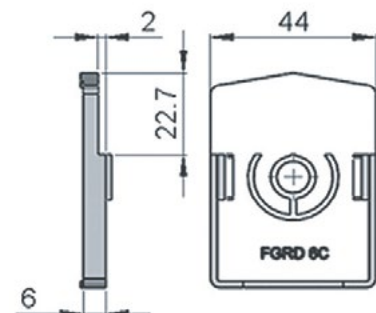

UOM: 10pcs / pk

FGRF-A35

Guide Rail Bracket A35 – Polyamide

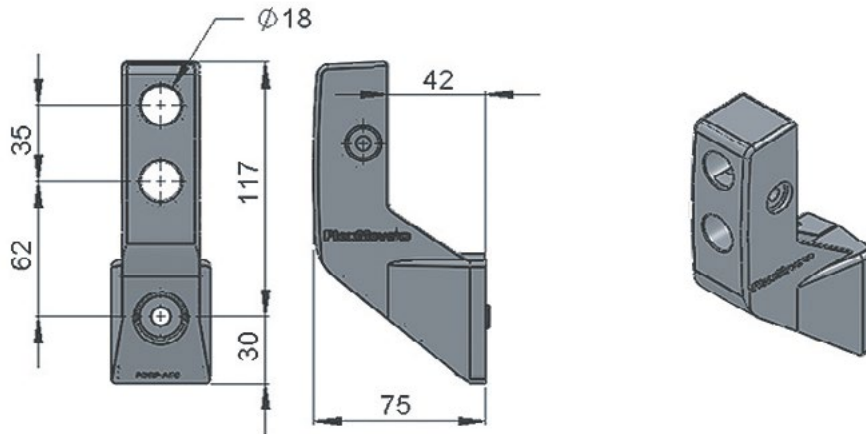

UOM: 10pcs / pk

To be used with guide rail support. For 1-2 guide rail levels.

FGRF-A110

Guide Rail Bracket A110 – Polyamide

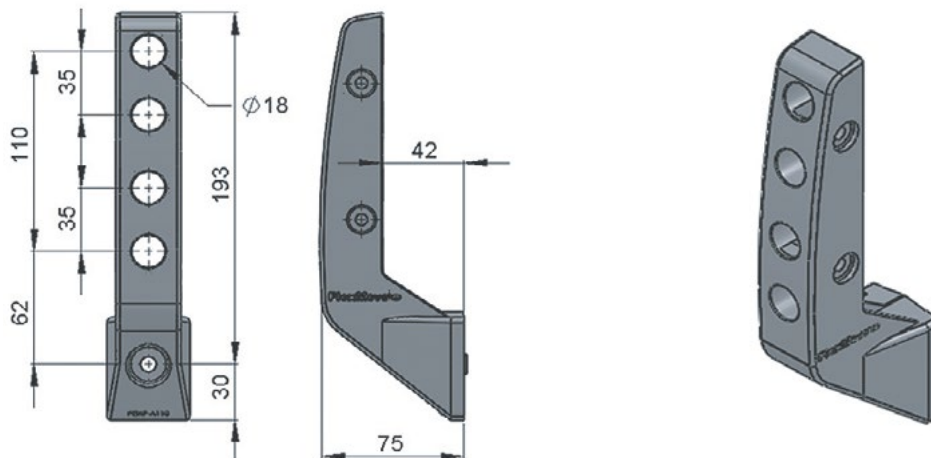

UOM: 10pcs / pk

To be used with guide rail support. For 1-4 guide rail levels.

FGRF-DP

FGRF Dummy Plug – Polyamide



UOM: 10pcs / pk

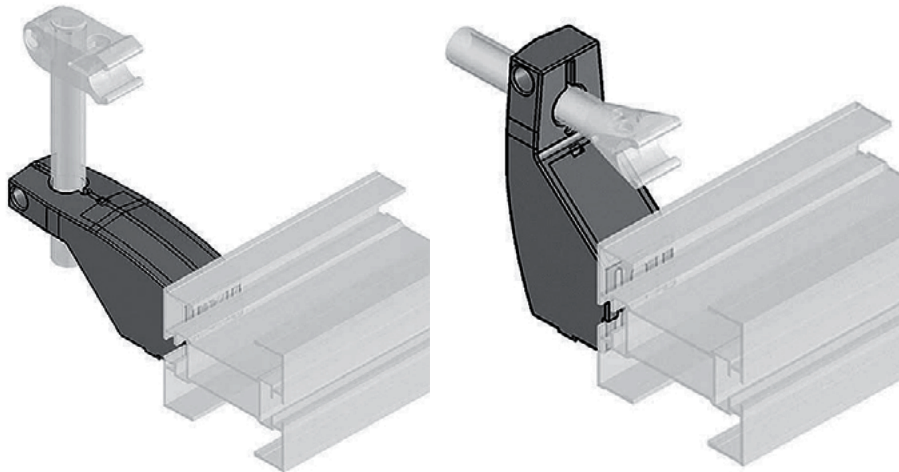

FGRB-40x18

Guide Rail Bracket, D = 18 mm - Polyamide

FGRB-40x20

Guide Rail Bracket, D = 20 mm - Polyamide

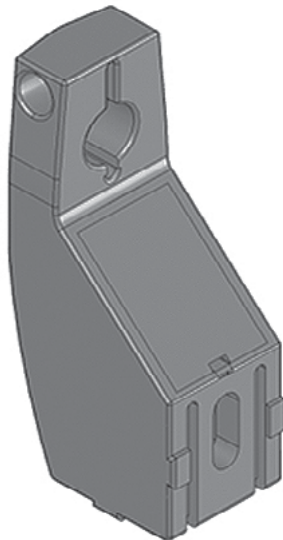

UOM: 10pcs / pk

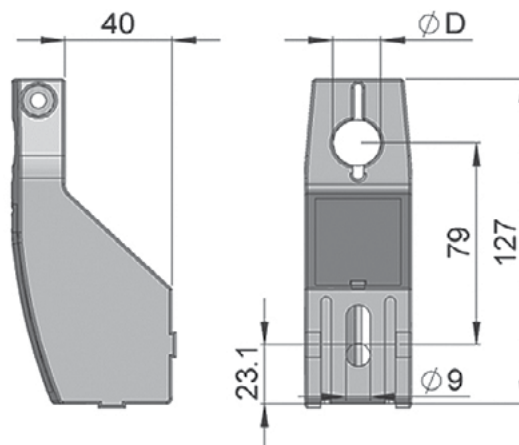

FGRB-40x15x20

Guide Rail Bracket - Polyamide

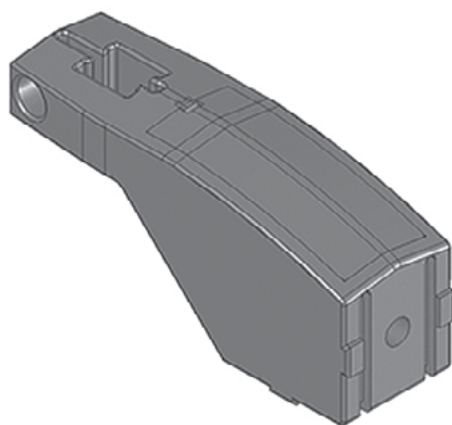

UOM: 10pcs / pk

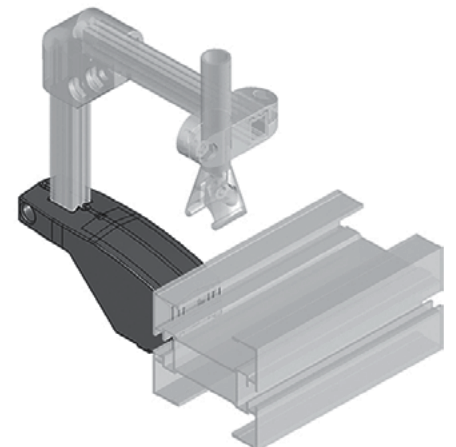
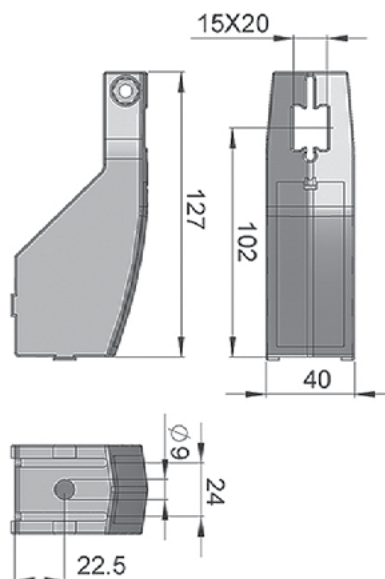

FGRD-6B Spacer for FGRB-40x ## - Polyamide

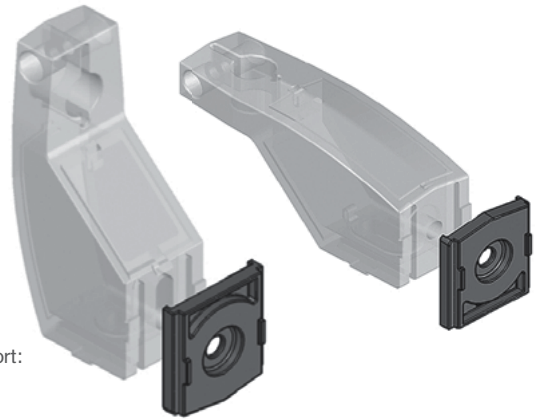
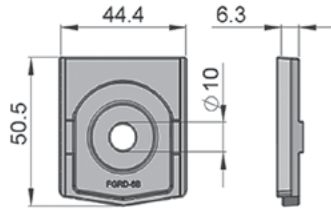

UOM: 10pcs / pk

For use with guide rail bracket support:
 FGRB - 40 x 18 / 20
 FGRB - 40 x 15 x 20

FGRB-18x18 Guide Rail Bracket, $\varnothing A = 18$ mm, $\varnothing B = 18$ mm - Polyamide

FGRB-18x20 Guide Rail Bracket, $\varnothing A = 18$ mm, $\varnothing B = 20$ mm - Polyamide

FGRB-20x20 Guide Rail Bracket, $\varnothing A = 20$ mm, $\varnothing B = 20$ mm - Polyamide

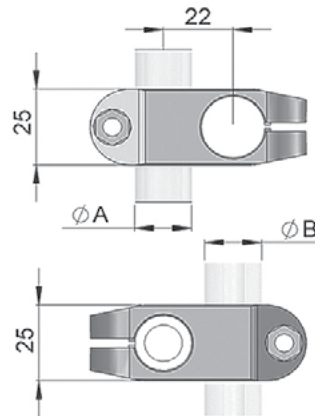
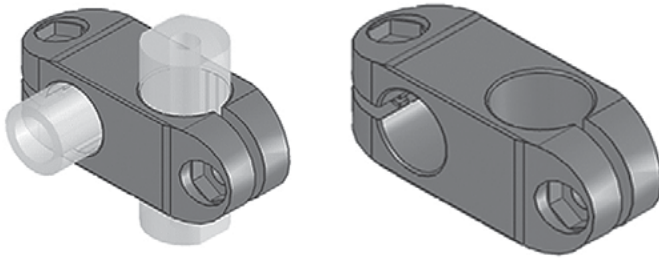

UOM: 10pcs / pk

FGRB-18x20T Guide Rail Bracket, $\varnothing A = 18$ mm - Polyamide

FGRB-20x20T Guide Rail Bracket, $\varnothing A = 20$ mm - Polyamide

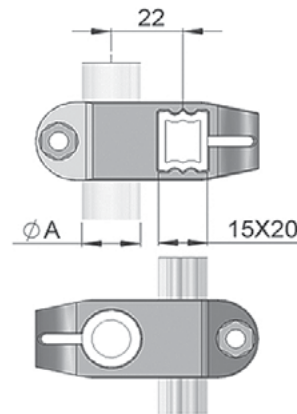
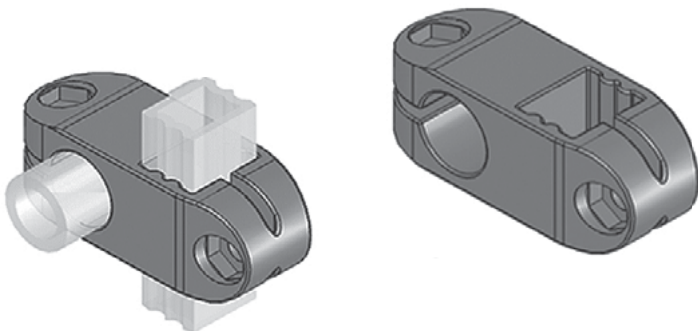

UOM: 10pcs / pk

FGRX-18x20

90° Corner Connector - Polyamide

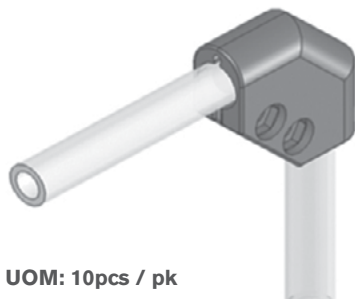

UOM: 10pcs / pk

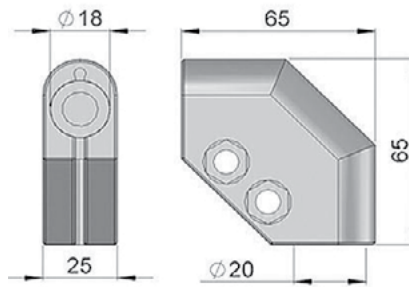

For use with :
 FGGR – 18 x 100 / 150 / 200 / 250 / 300
 FGDT – 70 / 80 / 100 / 150 / 200 / 250

FGRX-18x18

90° Corner Connector, ØA = 18mm, ØB = 18mm - Polyamide

FGRX-20x20

90° Corner Connector, ØA = 20 mm, ØB = 20 mm - Polyamide

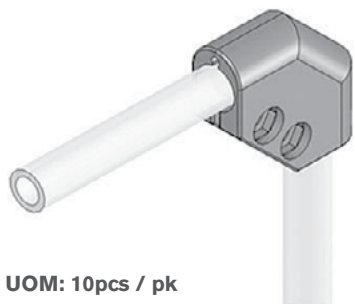

UOM: 10pcs / pk

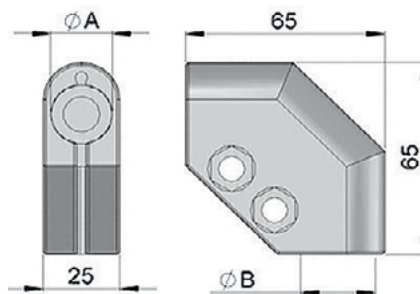

For use with :
 FGGR – 18 x 100 / 150 / 200 / 250 / 300
 FGDT – 70 / 80 / 100 / 150 / 200 / 250

90° Corner Connector - Polyamide

FGRX-15x20

90° Corner Connector - Polyamide

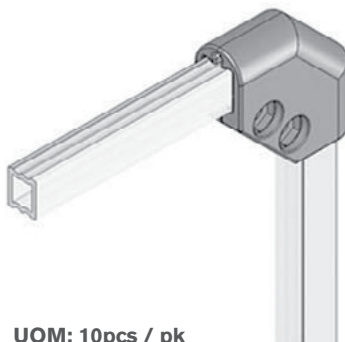

UOM: 10pcs / pk

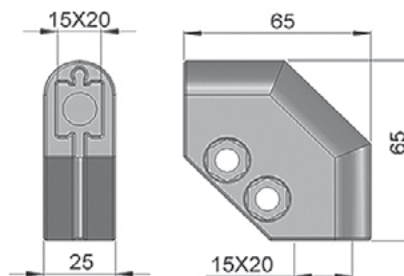

For use with : F
 GRR – 15 x 20 / 20 P

FGSP-DT

Distance Tube Spacer - POM

UOM: 10pcs / pk

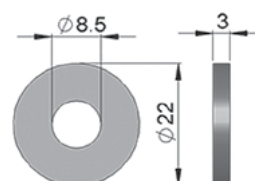
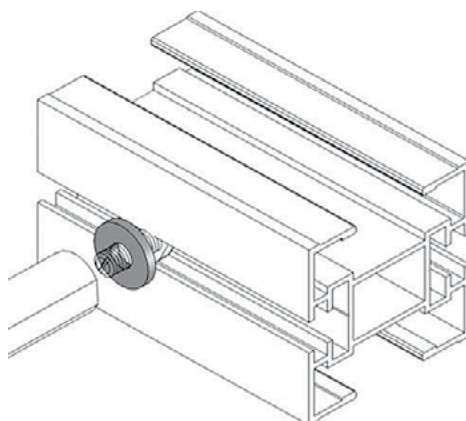

FGRD-6B Spacer for FGRB-40x ## - Polyamide

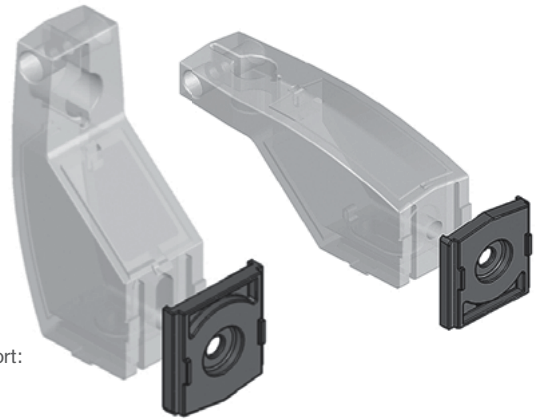
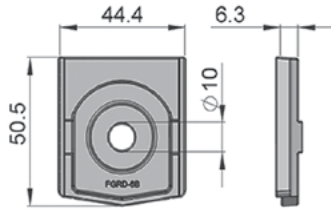

UOM: 10pcs / pk

For use with guide rail bracket support:
 FGRB – 40 x 18 / 20
 FGRB – 40 x 15 x 20

FGRB-HS High Side Guide Clip Assembly

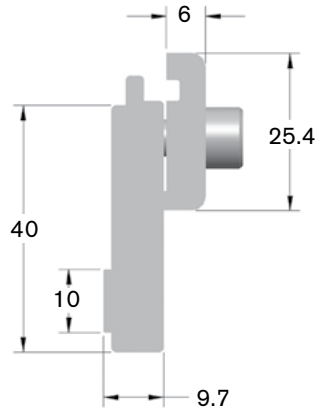
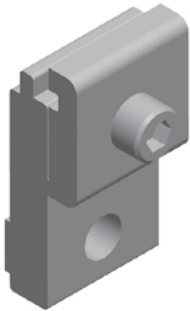

UOM: 10pcs / pk

Mounting to Beam:
 FATB-20(1)
 FALN-M8(1)
 FAFW-M8(1)

Available in North America only.

FGHS-70 Guide Rail, 70 mm High Side - Aluminum

FGHS-30 Guide Rail, 30 mm High Side - Aluminum

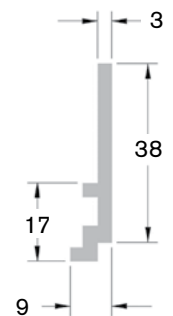
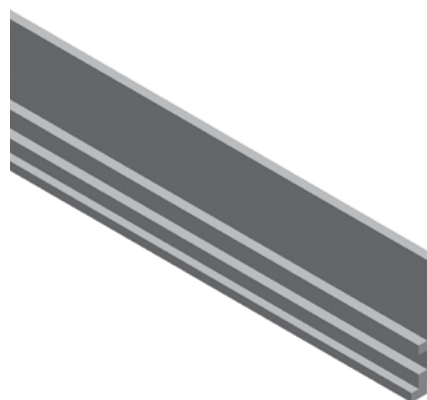
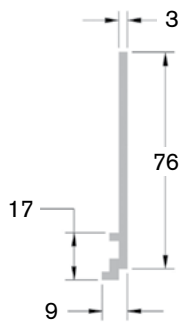
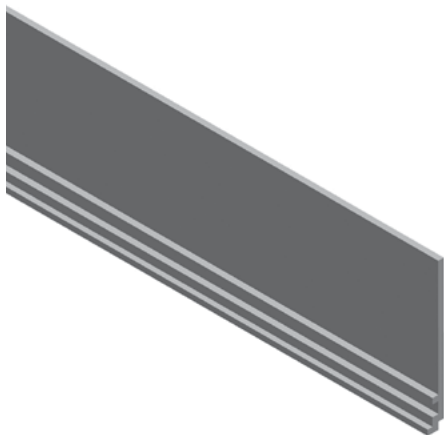

UOM: 3 meter/length

UOM: 3 meter/length

Available in North America only.

FGRB-PG

Pallet Guide Mounting Clip Assembly

UOM: 10pcs / pk

Available in North America only.

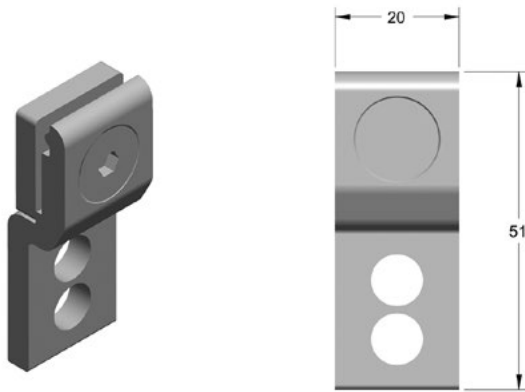

Mounting to Beam:
 FATB-20(1)
 FALN-M8(1)
 FAFW-M8(1)

FGPG-A

Pallet Guide Backing Rail - Aluminum

UOM: 3 meter/length

Available in North America only.

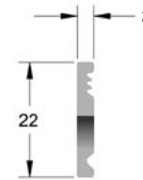

FGPG-U

Pallet Guide UHMW Guide

UOM: 3 meter/length

Available in North America only.

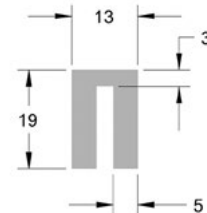
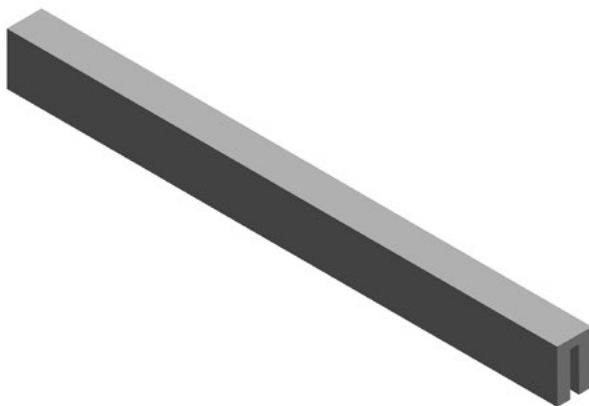

Direct Drive, Standard Load, Fixed Speed - 3/4 inch Shaft

Chart 6 90° eDrive® NEMA C-Face

- Sealed gearmotors
- NEMA 56 C face
- Totally enclosed, fan cooled
- 115V 1 phase includes switch, cord and overload protection
- 208-230/460V 3 phase wiring by others
- 60 Hz
- Order 3 phase starter separately, see page 226

Regulatory Approvals: CE, RoHS, SF

Part Number	Belt Speed						RPM	1 Phase			3 Phase			in.-lbs.	Nm	Starter Chart
	65 mm		85 mm		105 and 150 mm			Hp	kW	FLA	Hp	kW	FLA			
	Ft/min	M/min	Ft/min	M/min	Ft/min	M/min										
32M060ES4(vp)FN	39	12	39	12	41	12	29	0.5	0.37	7.4	0.5	0.37	2.1-2 / 1.0	226	25.5	M
32M040ES4(vp)FN	57	17	57	17	60	18	43	0.5	0.37	7.4	0.5	0.37	2.1-2 / 1.0	247	27.9	M
32M020ES4(vp)FN	115	35	115	35	120	37	86	0.5	0.37	7.4	0.5	0.37	2.1-2 / 1.0	248	27.9	M

(vp) = Voltage and Phase 11 = 115V, 1 phase 23 = 208 - 230 / 460V, 3 phase Available in North America only.

Direct Drive, Standard Load, Variable Speed - 3/4 inch Shaft

Chart 10 90° eDrive® NEMA C-Face VFD Rated

- Variable frequency drive, 6 - 60 Hz
- Sealed gearmotor
- NEMA 56 C Face
- Totally enclosed, fan cooled
- 230/460 Volts, 3 Phase
- Order controller separately, see page 226

Regulatory Approvals: CE, RoHS, SF

Part Number	Belt Speed						RPM*	3 Phase			in.-lbs.*	Nm*	Vari-Speed Control Chart
	65 mm		85 mm		105 and 150 mm			Hp	kW	FLA			
	Ft/min	M/min	Ft/min	M/min	Ft/min	M/min							
32M060ES423EN	9-39	2.9-121.6	9.6-38	2.9-12	10-41	3.1-12	29	0.75**	0.55	2.6 / 1.3	226	25.5	D
32M040ES423EN	14-57	4.4-17	14-57	4.3-17	15-60	4.6-18	43	0.75**	0.55	2.6 / 1.3	247	27.9	D
32M020ES423EN	92-115	8.7-35	28-113	8.6-35	30-120	9.2-37	86	0.75**	0.55	2.6 / 1.3	248	27.9	D
32M010ES423EN	58-231	18-70	57-228	17-70	60-242	18-74	173	0.75**	0.55	2.6 / 1.3	156	17.6	D

* = At 60 Hz ** = Motor is de-rated to 0.5 Hp (2.2 / 1.1 amp) for full torque throughout the speed range. Available in North America only.

CE Note: When buying a gearmotor only without the starter, the customer must supply their own on/off switch and motor overload protection to comply with the CE Safety Directive.

FLA = Full Load Amperes Some motors and gear reducers may normally operate hot to the touch. Consult factory for specific operating temperatures. **Note:** Dimensions = mm (in)

Direct Mount, SEW Equivalent, Fixed Speed - 20 mm Shaft

230/460 V 60 Hz

- Sealed Gearmotor
- SEW SA37 Size gearmotor
- Totally enclosed fan cooled
- 230/460 V 3 Phase
- 60 Hz
- Wiring by others

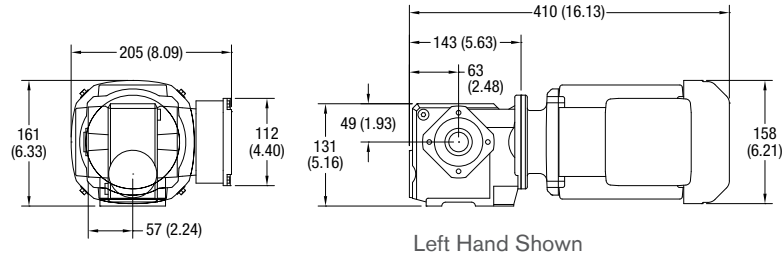

Part Number	Chain Speed				RPM	Hp	kW	Amps	in.-lbs.	Nm	Starter Chart
	FK, FS, FM, FU, FV		FC, FL								
	Ft/min	M/min	Ft/min	M/min							
FMM129(X)DS423EN	17.1	5.2	18	5.5	13	0.25	0.18	1.1/0.56	837	95	D
FMM067(X)DS423EN	32.8	10	34.8	10.6	25	0.5	0.37	1.9/0.95	699	79	D
FMM032(X)DS423EN	69.9	21.3	73.8	22.5	53	0.75	0.55	2.7/1.35	653	74	D
FMM015(X)DS423EN	150.3	45.8	158.5	48.3	114	1	0.75	3.1/1.57	444	50	D
FMM013(X)DS423EN	171.3	52.2	180.8	55.1	130	1	0.75	3.1/1.57	425	48	D
FMM010(X)DS423EN	225.4	68.7	237.9	72.5	171	1.5	1.1	4.2/2.1	490	56	D

Where (X) is L or R for Right Hand or Left Hand Gearmotor matching RH or LH Drive

230/400 V 50 Hz

- Sealed Gearmotor
- SEW SA37 Size gearmotor
- Totally enclosed fan cooled
- 230/400 V 3 Phase
- 50 Hz
- Wiring by others

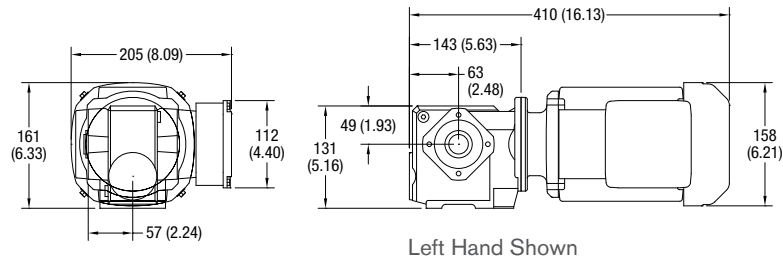

Part Number	Chain Speed				RPM	Hp	kW	Amps	in.-lbs.	Nm	Starter Chart
	FK, FS, FM, FU, FV		FC, FL								
	Ft/min	M/min	Ft/min	M/min							
FMZ099(X)DS423EN	17.1	5.2	18	5.5	13	0.33	0.25	1.3/0.76	628	71	B
FMZ060(X)DS423EN	30.2	9.2	31.8	9.7	23	0.5	0.37	1.9/1.09	717	81	B
FMZ029(X)DS423EN	63.3	19.3	66.6	20.3	48	0.75	0.55	2.6/1.52	478	54	B
FMZ013(X)DS423EN	137.1	41.8	144.7	44.1	104	1	0.75	3.1/1.79	363	41	B
FMZ009(X)DS423EN	205.7	62.7	213.9	66.1	156	1.5	1.1	4.1/2.38	336	38	B
FMZ007(X)DS423EN	284.8	86.8	300.5	91.60	216	2	1.5	5.6/3.23	372	42	B

Where (X) is L or R for Right Hand or Left Hand Gearmotor matching RH or LH Drive

SEW gearmotors are products of SEW Eurodrive

CE Note: When buying a gearmotor only without the starter, the customer must supply their own on/off switch and motor overload protection to comply with the CE Safety Directive.

FLA = Full Load Amperes Some motors and gear reducers may normally operate hot to the touch. Consult factory for specific operating temperatures. **Note:** Dimensions = mm (in)

Direct Mount, SEW Equivalent, Variable Speed - 20 mm Shaft

230/460 V 60 Hz

- Sealed Gearmotor
- SEW SA37 Size gearmotor
- Totally enclosed fan cooled
- 230/460 V 3 Phase
- 60 Hz
- Wiring by others

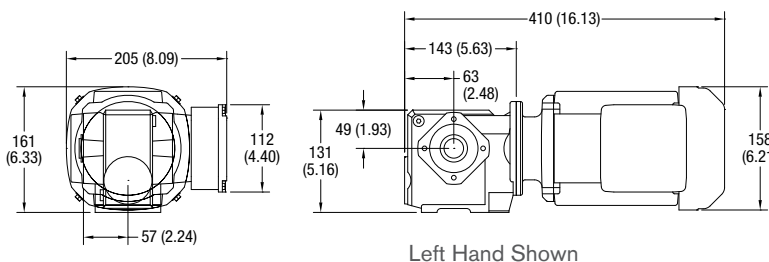

Regulatory Approvals



Part Number	Chain Speed				RPM	Hp	kW	Amps	in.-lbs.	Nm	Starter Chart
	FK, FS, FM, FU, FV		FC, FL								
	Ft/min	M/min	Ft/min	M/min							
FMM129(X)DS423EN	2.9 - 17.1	0.9 - 5.2	3 - 18	0.9 - 5.5	13	0.25	0.18	1.1/0.56	837	95	D
FMM067(X)DS423EN	5.5 - 32.8	1.7 - 10	5.8 - 34.8	1.8 - 10.6	25	0.5	0.37	1.9/0.95	699	79	D
FMM032(X)DS423EN	11.7 - 69.9	3.6 - 21.3	12.3 - 73.8	3.8 - 22.5	53	0.75	0.55	2.7/1.35	653	74	D
FMM015(X)DS423EN	25.1 - 150.3	7.6 - 45.8	26.4 - 158.5	8.1 - 48.3	114	0.75	0.55	2.7/1.35	341	39	D
FMM013(X)DS423EN	28.6 - 171.3	8.7 - 52.2	30.1 - 180.8	9.2 - 55.1	130	1	0.75	3.1/1.57	425	48	D
FMM010(X)DS423EN	37.6 - 225.4	11.5 - 68.7	39.7 - 237.9	12.1 - 72.5	171	1.5	1.1	4.2/2.1	490	56	D

Where (X) is L or R for Right Hand or Left Hand Gearmotor matching RH or LH Drive

230/400 V 50 Hz

- Sealed Gearmotor
- SEW SA37 Size gearmotor
- Totally enclosed fan cooled
- 230/400 V 3 Phase
- 50 Hz
- Wiring by others

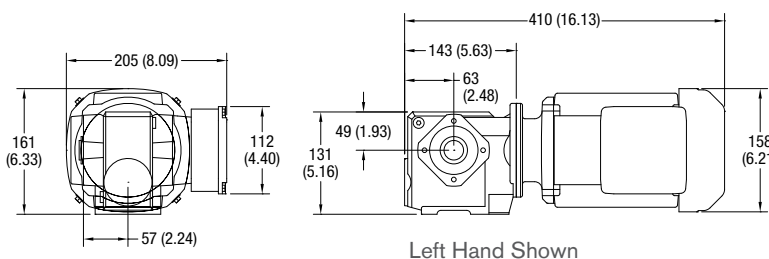

Regulatory Approvals



Part Number	Chain Speed				RPM	Hp	kW	Amps	in.-lbs.	Nm	Starter Chart
	FK, FS, FM, FU, FV		FC, FL								
	Ft/min	M/min	Ft/min	M/min							
FMZ099(X)DS423EN	3.4 - 17.1	1 - 5.2	3.6 - 18	1.1 - 5.5	13	0.33	0.25	1.3/0.76	628	71	B
FMZ060(X)DS423EN	6 - 30.2	1.8 - 9.2	6.4 - 31.8	1.9 - 9.7	23	0.5	0.37	1.9/1.09	717	81	B
FMZ029(X)DS423EN	12.7 - 63.3	3.9 - 19.3	13.3 - 66.6	4.1 - 20.3	48	0.75	0.55	2.6/1.52	478	54	B
FMZ013(X)DS423EN	27.4 - 137.1	8.4 - 41.8	28.9 - 144.7	8.8 - 44.1	104	1	0.75	3.1/1.79	363	41	B
FMZ009(X)DS423EN	41.1 - 205.7	12.5 - 62.7	43.4 - 213.9	13.2 - 66.1	156	1.5	1.1	4.1/2.38	336	38	B
FMZ007(X)DS423EN	57 - 284.8	17.4 - 86.8	60.1 - 300.5	18.3 - 91.60	216	2	1.5	5.6/3.23	372	42	B

Where (X) is L or R for Right Hand or Left Hand Gearmotor matching RH or LH Drive

SEW gearmotors are products of SEW Eurodrive

CE Note: When buying a gearmotor only without the starter, the customer must supply their own on/off switch and motor overload protection to comply with the CE Safety Directive.

FLA = Full Load Amperes Some motors and gear reducers may normally operate hot to the touch. Consult factory for specific operating temperatures. **Note:** Dimensions = mm (in)

Suspended Mount, SEW Equivalent, Fixed Speed - 20 mm Shaft

230/460 V 60 Hz

- Sealed Gearmotor
- SEW SA37 Size gearmotor
- Totally enclosed fan cooled
- 230/460 V 3 Phase
- 60 Hz
- Wiring by others

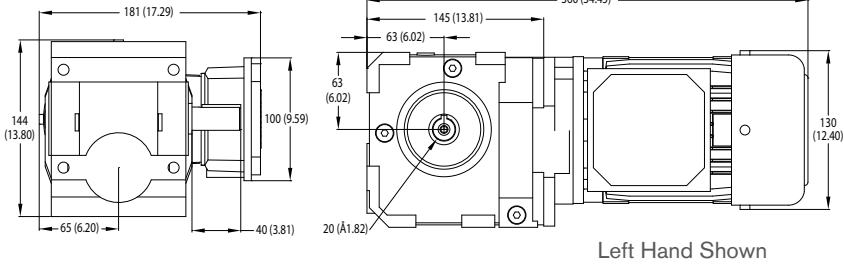

Left Hand Shown

Regulatory Approvals



Part Number	Chain Speed				RPM	Hp	kW	Amps	in.-lbs.	Nm	Starter Chart
	FK, FS, FM, FU, FV		FC, FL								
	Ft/min	M/min	Ft/min	M/min							
FMM129(X)SS423EN	17.1	5.2	18	5.5	13	0.25	0.18	1.1/0.56	837	95	D
FMM067(X)SS423EN	32.8	10	34.8	10.6	25	0.5	0.37	1.9/0.95	699	79	D
FMM032(X)SS423EN	69.9	21.3	73.8	22.5	53	0.75	0.55	2.7/1.35	653	74	D
FMM015(X)SS423EN	150.3	45.8	158.5	48.3	114	0.75	0.55	2.7/1.35	341	39	D
FMM013(X)SS423EN	171.3	52.2	180.8	55.1	130	1	0.75	3.1/1.57	425	48	D
FMM010(X)SS423EN	225.4	68.7	237.9	72.5	171	1.5	1.1	4.2/2.1	490	56	D

Where (X) is L or R for Right Hand or Left Hand Gearmotor matching RH or LH Drive

230/400 V 50 Hz

- Sealed Gearmotor
- SEW SA37 Size gearmotor
- Totally enclosed fan cooled
- 230/400 V 3 Phase
- 50 Hz
- Wiring by others

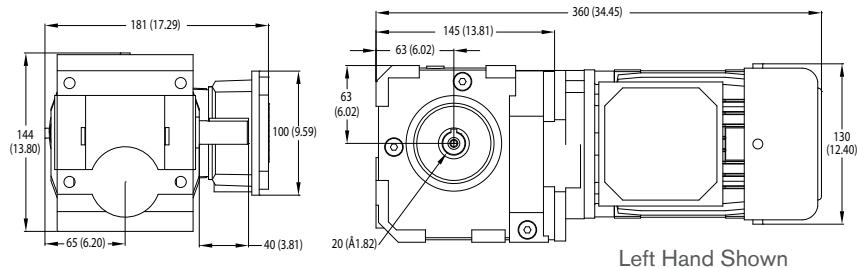

Left Hand Shown

Regulatory Approvals



Part Number	Chain Speed				RPM	Hp	kW	Amps	in.-lbs.	Nm	Starter Chart
	FK, FS, FM, FU, FV		FC, FL								
	Ft/min	M/min	Ft/min	M/min							
FMZ099(X)SS423EN	17.1	5.2	18	5.5	13	0.33	0.25	1.3/0.76	628	71	B
FMZ060(X)SS423EN	30.2	9.2	31.8	9.7	23	0.5	0.37	1.9/1.09	717	81	B
FMZ029(X)SS423EN	63.3	19.3	66.6	20.3	48	0.75	0.55	2.6/1.52	478	54	B
FMZ013(X)SS423EN	137.1	41.8	144.7	44.1	104	1	0.75	3.1/1.79	363	41	B
FMZ009(X)SS423EN	205.7	62.7	213.9	66.1	156	1.5	1.1	4.1/2.38	336	38	B
FMZ007(X)SS423EN	284.8	86.8	300.5	91.60	216	2	1.5	5.6/3.23	372	42	B

Where (X) is L or R for Right Hand or Left Hand Gearmotor matching RH or LH Drive

SEW gearmotors are products of SEW Eurodrive

CE Note: When buying a gearmotor only without the starter, the customer must supply their own on/off switch and motor overload protection to comply with the CE Safety Directive.

FLA = Full Load Amperes Some motors and gear reducers may normally operate hot to the touch. Consult factory for specific operating temperatures. **Note:** Dimensions = mm (in)

Suspended Mount, SEW Equivalent, Variable Speed - 20 mm Shaft

230/460 V 60 Hz

- Sealed Gearmotor
- SEW SA37 Size gearmotor
- Totally enclosed fan cooled
- 230/460 V 3 Phase
- 60 Hz
- Wiring by others

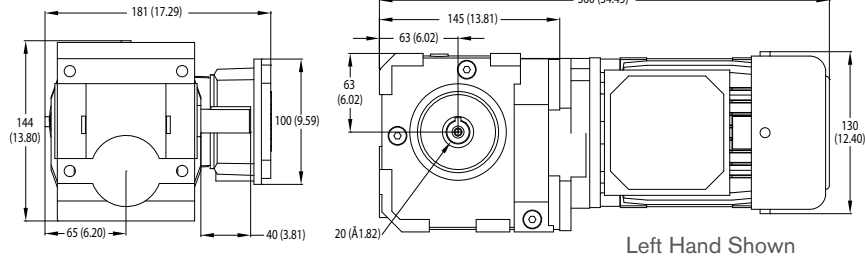

Regulatory Approvals



Part Number	Chain Speed				RPM	Hp	kW	Amps	in.-lbs.	Nm	Starter Chart
	FK, FS, FM, FU, FV		FC, FL								
	Ft/min	M/min	Ft/min	M/min							
FMM129(X)SS423EN	2.9 - 17.1	0.9 - 5.2	3 - 18	0.9 - 5.5	13	0.25	0.18	1.1/0.56	837	95	D
FMM067(X)SS423EN	5.5 - 32.8	1.7 - 10	5.8 - 34.8	1.8 - 10.6	25	0.5	0.37	1.9/0.95	699	79	D
FMM032(X)SS423EN	11.7 - 69.9	3.6 - 21.3	12.3 - 73.8	3.8 - 22.5	53	0.75	0.55	2.7/1.35	653	74	D
FMM015(X)SS423EN	25.1 - 150.3	7.6 - 45.8	26.4 - 158.5	8.1 - 48.3	114	0.75	0.55	2.7/1.35	341	39	D
FMM013(X)SS423EN	28.6 - 171.3	8.7 - 52.2	30.1 - 180.8	9.2 - 55.1	130	1	0.75	3.1/1.57	425	48	D
FMM010(X)SS423EN	37.6 - 225.4	11.5 - 68.7	39.7 - 237.9	12.1 - 72.5	171	1.5	1.1	4.2/2.1	490	56	D

Where (X) is L or R for Right Hand or Left Hand Gearmotor matching RH or LH Drive

230/400 V 50 Hz

- Sealed Gearmotor
- SEW SA37 Size gearmotor
- Totally enclosed fan cooled
- 230/400 V 3 Phase
- 50 Hz
- Wiring by others

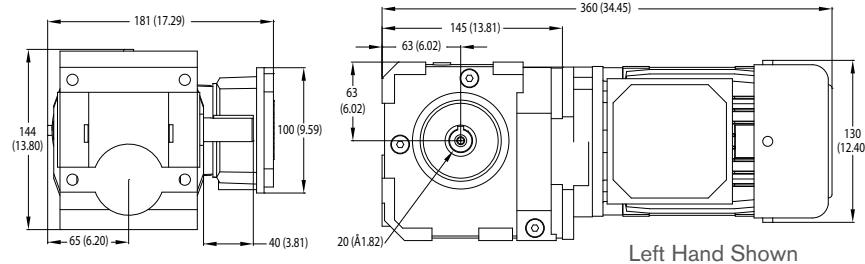

Regulatory Approvals



Part Number	Chain Speed				RPM	Hp	kW	Amps	in.-lbs.	Nm	Starter Chart
	FK, FS, FM, FU, FV		FC, FL								
	Ft/min	M/min	Ft/min	M/min							
FMZ099(X)SS423EN	3.4 - 17.1	1 - 5.2	3.6 - 18	1.1 - 5.5	13	0.33	0.25	1.3/0.76	628	71	B
FMZ060(X)SS423EN	6 - 30.2	1.8 - 9.2	6.4 - 31.8	1.9 - 9.7	23	0.5	0.37	1.9/1.09	717	81	B
FMZ029(X)SS423EN	12.7 - 63.3	3.9 - 19.3	13.3 - 66.6	4.1 - 20.3	48	0.75	0.55	2.6/1.52	478	54	B
FMZ013(X)SS423EN	27.4 - 137.1	8.4 - 41.8	28.9 - 144.7	8.8 - 44.1	104	1	0.75	3.1/1.79	363	41	B
FMZ009(X)SS423EN	41.1 - 205.7	12.5 - 62.7	43.4 - 213.9	13.2 - 66.1	156	1.5	1.1	4.1/2.38	336	38	B
FMZ007(X)SS423EN	57 - 284.8	17.4 - 86.8	60.1 - 300.5	18.3 - 91.60	216	2	1.5	5.6/3.23	372	42	B

Where (X) is L or R for Right Hand or Left Hand Gearmotor matching RH or LH Drive

SEW gearmotors are products of SEW Eurodrive

CE Note: When buying a gearmotor only without the starter, the customer must supply their own on/off switch and motor overload protection to comply with the CE Safety Directive.

FLA = Full Load Amperes Some motors and gear reducers may normally operate hot to the touch. Consult factory for specific operating temperatures. **Note:** Dimensions = mm (in)

Variable Speed Controllers

Chart D		Full Feature VFD Controller						
<ul style="list-style-type: none"> • Full feature VFD control • IP65 plastic enclosure • Digital display • Keypad with Start/Stop, Forward/Reverse and speed variations • Includes cord to motor • Power to controller by others • Mounting hardware 							<p>Regulatory Approvals</p>	
Part Number	Input Volts	Input Phase	Input Hz	Output Volts	Output Phase	Max Hp	Output Amps*	Reversing
32MVA1122(O)	115	1	60	230	3	0.5	2.3	Yes
32MVA2122(O)	230	1	60	230	3	0.5	2.3	Yes
32MVA1121(O)	115	1	60	230	3	1.0	4.3	Yes
32MVA2121(O)	230	1	60	230	3	1.0	4.3	Yes
32MVA2127(O)	230	1	60	230	3	2.0	7.0	Yes
32MVA2322(O)	230	3	60	230	3	0.5	4.3	Yes
32MVA2321(O)	230	3	60	230	3	1.0	2.3	Yes
32MVA2327(O)	230	3	60	230	3	2.0	7.0	Yes
32MVA4342(O)	460	3	60	460	3	0.5	1.2	Yes
32MVA4341(O)	460	3	60	460	3	1.0	2.2	Yes
32MVA4347(O)	460	3	60	460	3	2.0	4.1	Yes

In order for this drive to meet full CE requirements for European application a separate CE approve RFI filter must be installed. Product shown in chart B above have this filter pre-installed and are recommended for use in the European Union.

(O) = Optional M12 Accessory Port No Option = No Accessory Port E = M12 Port wired for End Stop Photo Eye Application
 I = M12 port wired for Index Photo Eye Application Note: E or I options will work with Dorner Control Stop or Jog Button Accessories

Jog Push Button Kit



Specifications

- Momentary contact push button
- Plastic Nema 12 enclosure
- Quick disconnect receptacle
- Mounting for 2200/3200 and Support Stands
- Horizontal or vertical mount

Part Number	75M-JG-1
-------------	----------

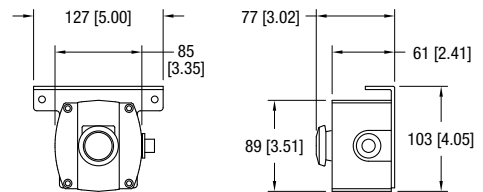

Horizontal Mount

Not compatible with Brushless DC Controllers

SEW gearmotors are products of SEW Eurodrive

CE Note: When buying a gearmotor only without the starter, the customer must supply their own on/off switch and motor overload protection to comply with the CE Safety Directive.

FLA = Full Load Amperes Some motors and gear reducers may normally operate hot to the touch. Consult factory for specific operating temperatures. **Note:** Dimensions = mm (in)

Manual Motor Starters

Manual motor starts are manual electronic disconnects that provide motor overload protection and are required by the National Electric Code (NEC) for safe motor operation.

- IP 55 Enclosure
- Push button Start / Stop
- Includes mounting hardware

Regulatory Approvals

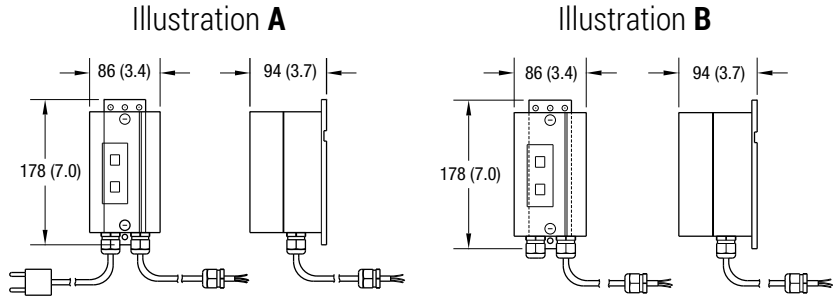



Chart I		230/400V 50Hz to 2.5 amp		
<ul style="list-style-type: none"> • 230 Volts, 1 phase includes cord, plug and starter • 230/400 Volts, 3 phase wiring to starter by others • Wiring between motor and starter provided when ordered together • 50 Hz 				
Part Number	In Volts	In Phase	Amp Range	Illustration
62(c)M21T	230	1	1.6 - 2.5	A
62(c)M23T	230	3	1.0 - 1.6	B
62(c)M43T	400	3	0.63 - 1.0	B

Chart J		230/400V 50 Hz to 4 amp		
<ul style="list-style-type: none"> • 230 Volts, 1 phase includes cord, plug and starter • 230/400V, 3 phase wiring to starter by others • Wiring between motor and starter provided when ordered together • 50 Hz 				
Part Number	In Volts	In Phase	Amp Range	Illustration
62(c)M21J	230	1	2.5 - 4.0	A
62(c)M23J	230	3	1.6 - 2.5	B
62(c)M43J	400	3	1.0 - 1.6	B

Chart L		230/460V 60 Hz to 1.6 amp		
<ul style="list-style-type: none"> • 230/460 Volts, 3 phase wiring to starter by others • Wiring between motor and starter provided when ordered together • 60 Hz 				
Part Number	In Volts	In Phase	Amp Range	Illustration
62MM23L	230	3	1.0 - 1.6	B
62MM43L	460	3	0.4 - .63	B

Chart M		230/460V 60Hz to 2.5 amp		
<ul style="list-style-type: none"> • 230/460 Volts, 3 phase wiring to starter by others • Wiring between motor and starter provided when ordered together • 60 Hz 				
Part Number	In Volts	In Phase	Amp Range	Illustration
62MM23M	208-230	3	1.6 - 2.5	B
62MM43M	460	3	1.0 - 1.6	B

Chart P		230/460V 60Hz to 4 amp		
<ul style="list-style-type: none"> • 230/460 Volts, 3 phase wiring to starter by others • Wiring between motor and starter provided when ordered together • 60 Hz 				
Part Number	In Volts	In Phase	Amp Range	Illustration
62MM23U	208-230	3	2.5 - 4.0	B
62MM43P	460	3	1.6 - 2.5	B

Chart Q		230/460V 60Hz to 6.3 amp		
<ul style="list-style-type: none"> • 230/460 Volts, 3 phase wiring to starter by others • Wiring between motor and starter provided when ordered together • 60 Hz 				
Part Number	In Volts	In Phase	Amp Range	Illustration
62MM23Q	208-230	3	4.0 - 6.3	B
62MM43Q	460	3	2.5 - 4.0	B

CE Note: When buying a gearmotor only without the starter, the customer must supply their own on/off switch and motor overload protection to comply with the CE Safety Directive.

FLA = Full Load Amperes Some motors and gear reducers may normally operate hot to the touch. Consult factory for specific operating temperatures. **Note:** Dimensions = mm (in)



Pallets

- Pallet Sizes: 105 mm Conveyor

180 mm wide	Length		
	100	150	200

- Recessed hardened stop plates provide complete access to full top plate for part tooling
- Maximum weight per pallet = 9 kg (20 lbs)
- Base Pucks
 - 19.05 mm (.75 in) thick molded static dissipative nylon
 - Round shape to match conveyor guides
 - Optional cushioning bumper can be added to base pucks to reduce noise and impacts
- Pallet is 12.7 mm (.5 in) thick tool plate anodized aluminum
- Contains pin tracking system to guide pallet on conveyor and divert modules
- Pallets can be purchased as assembled units or as kits containing all components except for aluminum top plate
- See page 163 for pallet sensor brackets
- Available in North America only.

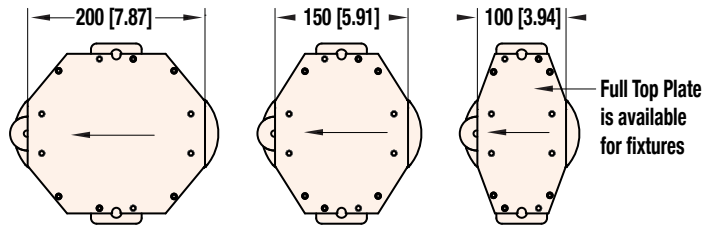
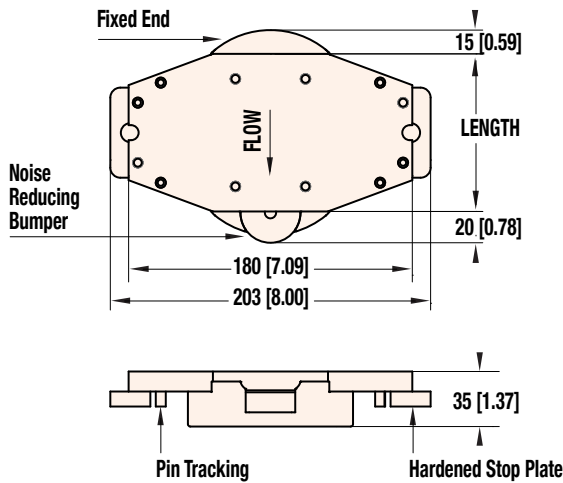

Pallets

22 SF P M WWW - LLL A

Pallet Options:
 A = Assembled with std 1/2" aluminum top plate
 B = Assembled with std 1/2" aluminum top plate and bumper on one end
 C = Kit only without aluminum top plate
 D = Kit only without aluminum top plate includes bumper on one end

Length Reference:
 100 = 100 mm 150 = 150 mm
 200 = 200 mm

Width Reference: 105 = 105 mm

Documentation Language: M = US

P = Pallet

Note: Contact factory for detailed drawing of top plate **Note:** Dimensions = mm (in)

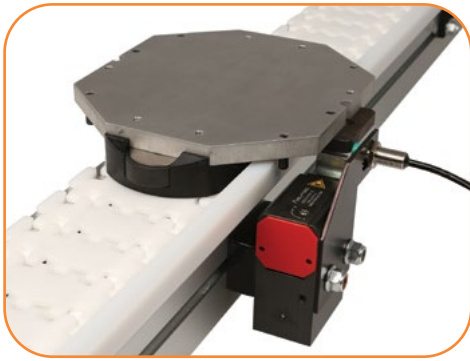

Cushioned



Non-Cushioned

Pallet Stops

- All stops are pneumatic single acting with spring return, double acting available
- Stops can be cushioned or non-cushioned for use with pallets
- Stops can be added to either side of the conveyor without guide modification
- Optional sensor mounts for pallet
- Sensor mounts are for standard 12 mm diameter proximity switch
- Pallet assembly includes stop, mounting bracket, hardware and pneumatic push in fittings for 6.35 mm (.25 in) air line
- See page 163 for pallet sensor brackets
- Available in North America only.

Speed vs. Load Characteristics

Belt Speed M/min (ft./min)	Max. Allowed Accumulated Load Kg (lbs.)
Cushioned Stops	
6.1 (20)	54 (120)
9.1 (30)	36 (80)
12.2 (40)	32 (70)
18.3 (60)	27 (60)
23 (75)	23 (50)
31 (100)	16 (35)

Belt Speed M/min (ft./min)	Max. Allowed Accumulated Load Kg (lbs.)
Non-Cushioned Stops*	
6.1 (20)	68 (150)
9.1 (30)	68 (150)
12.2 (40)	68 (150)
18.3 (60)	64 (140)
23 (75)	55 (120)
31 (100)	45 (100)

*Note: Pallet bumpers are recommended.

Stops

22 SF S M WWW - N N

— Sensor Option:
N = No Sensor Bracket Included
B = Sensor Bracket Included

— Stop Type:
C = Cushioned Pallet Type
F = Non-Cushioned Pallet Type

— Width Reference: 105 = 105 mm

— Documentation Language: M = US

— S = Stop

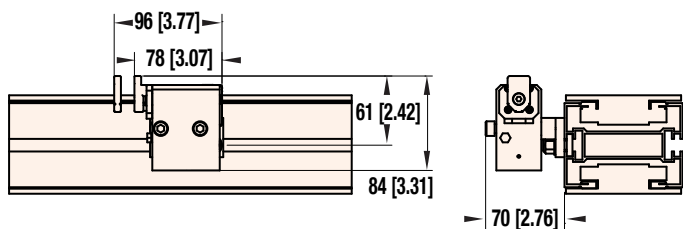

Cushioned

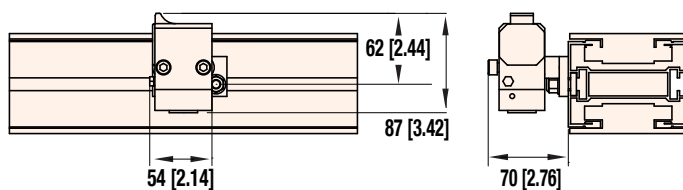

Non-Cushioned

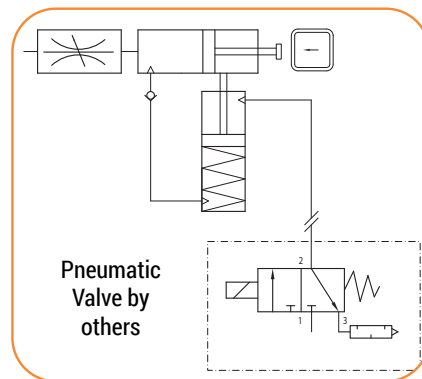

Cushioned Pneumatic Schematic

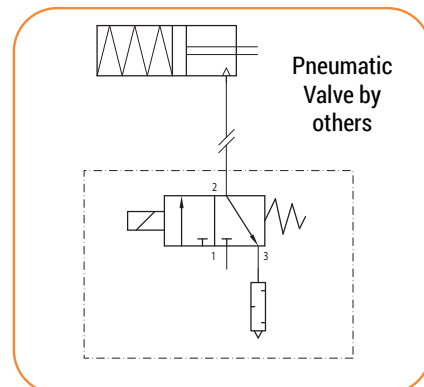

Non-Cushioned Pneumatic Schematic

Note: Dimensions = mm (in)

Diverts and Merges

All merge and divert kits require pallet stops to be used for product traffic control. Stops are not included in the kit and should be ordered separately. Available in North America only.

Divert Models

- Pneumatic diverter position is adjustable in both positions
- Height of the divert arm is adjustable
- The assembly/kit is a combination of parts
- Requires the conveyor to have #18 guiding
- Cutting and fitting of the guiding is required
- Kit includes:
 - Divert assembly including pneumatic push in fittings for 6.35 mm (.25 in) air line
 - Turning wheel guide ring
 - Guide lead-in parts
 - Transition guiding and mounting clips
- Optional sensor mounts for diverter
- Sensor mounts are for air cylinder reed switch.
- Optional sensor mount for pallet
- Sensor mounts are for standard Dorner 18 mm barrel type photoeyes

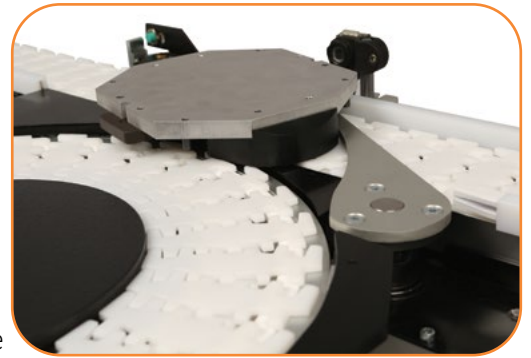

Divert Module with Sensors



Divert Module Only

Merge Models

- This kit is for merge only and does not include a diverter
- Requires the conveyor to have #18 guiding
- Cutting and fitting of the guiding is required
- Kit includes:
 - Fixed merge guide
 - Turning wheel guide ring
 - (4) Guide lead-in parts
- Optional sensor mount for pallet
- Sensor mounts are for standard Dorner 18 mm barrel type photoeyes

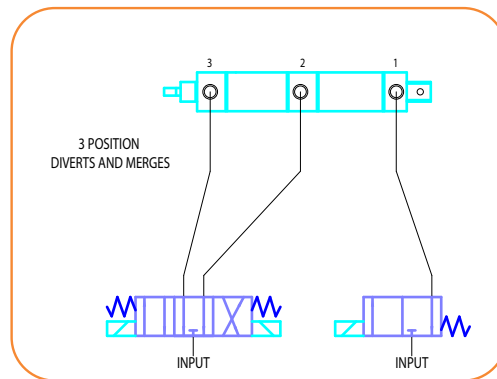
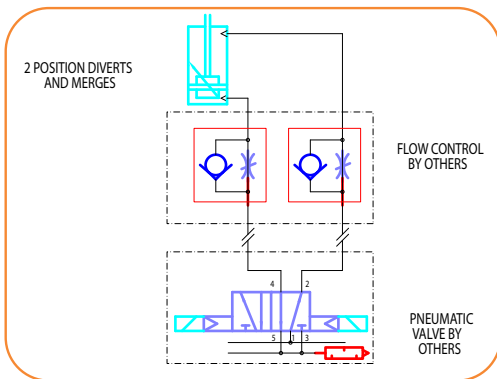

Divert/Merge Orientations

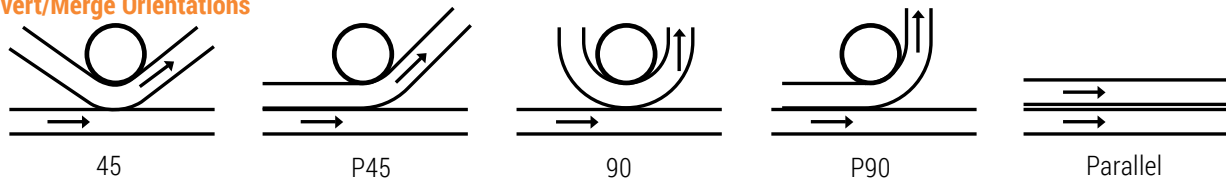

Diverts										
22SF	D	M	WWW	-	AAA	2	C	R	1	L
Direction: L = Left R = Right Pallet Photoeye Brackets: 1 = No Pallet Photoeye Brackets 2 = Includes Pallet Photoeye Brackets Divert Arm Sensors: N = No Reed Switches R = Reed Switches Included Stop Type: C = Cushioned F = Non cushioned N = No Stops Included Divert Type: 2 = Divert only, 2 Position 3 = Divert and Merge, 3 Position Angle: 045 = 45° 090 = 90° 000 = Parallel P45 = Parallel 45 P90 = Parallel 90 Width Reference: 105 = 105 mm Documentation Language: M = US D = Divert and Merge										

Fixed Merge						
22SF	M	M	WWW	-	AAA	L
Direction: L = Left R = Right Angle: 045 = 45° 090 = 90° 000 = Parallel P45 = Parallel 45 P90 = Parallel 90 Width Reference: 105 = 105 mm Documentation Language: M = US M = Fixed Merge						

Note: Dimensions = mm (in)

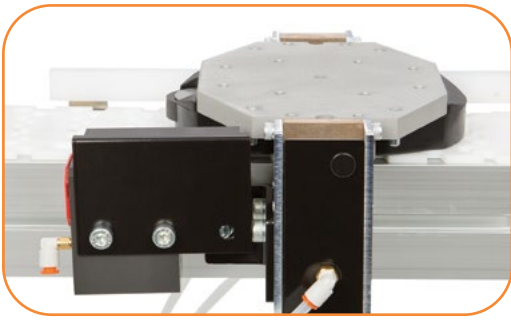

Lift and Locate Module with Pallet in Located Position



Lift and Locate Module Only

Lift and Locates:

- Conveyor width: 105 mm
- Lifts from outside of conveyor – provides 90.7 kg (200 lbs) of vertical holding force
- Lifts pneumatic operated
- Rated for pressures up to 100 psi.
- Repeatability accuracy of $\pm .1$ mm (0.004 in)
- Includes (1) Cushioned or Non-Cushioned pallet stop
- Includes sensor mounts for lift cylinder and pallet
- Sensor mounts are for standard 12 mm diameter proximity switch
- Can be supported by conveyor or have SmartFlex support post added for additional support
- Includes push-in pneumatic push in fittings for 6.35 mm (.25 in) air line
- Available in North America only.

Lift and Locate						
22 SF	L	M	WWW	-	N	L
						Stop Location: L = Left R = Right
						Stop Type: C = Cushioned Stop F = Non-Cushioned Stop
						Width Reference: 105 = 105 mm
						Documentation Language: M = US
						L = Lift and Locate

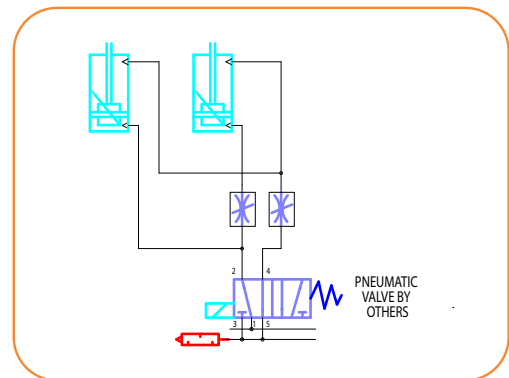
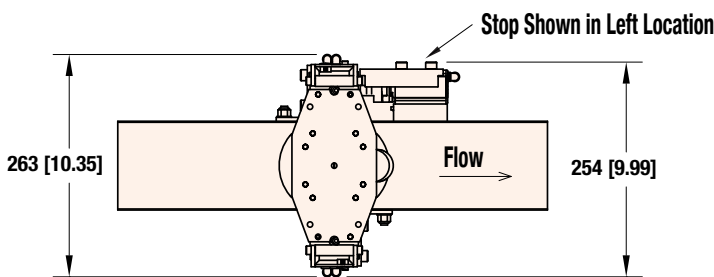

Pallet in Locked Location

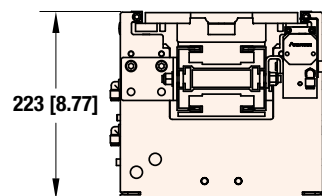
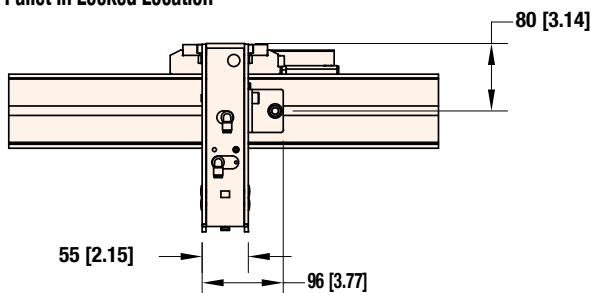

Note: Dimensions = mm (in)

Regulatory Approvals:

Conveyors:

All Dorner FlexMove Series standard conveyors (not including gearmotors and controllers) are CE approved. CE approval follows the provisions of the following directives; Machine Directive 2006/42/EC, EU Low Voltage Directive 2006/95/EC, and EMC Directive 2004/108/EC. All conveyors are marked with the CE symbol on the Dorner serial number tag located on the conveyor frame. Contact the factory for the CE Declaration of Conformity.

All Dorner FlexMove Series standard conveyors (not including gearmotors and controllers) are designed and manufactured in accordance with the restrictions defined in the "Restriction of Hazardous Substances" directive, citation 2011/65/EU, commonly known as RoHS. All conveyors are marked with the RoHS symbols on the Dorner serial number tag located on the conveyor frame.

Gearmotors and Controllers:

All Dorner FlexMove Series gearmotors and controllers carry one or more of the following approvals. Products are not covered by each approval. Please see the appropriate part number on the Gearmotor and controller charts located in this manual. In addition, regulatory symbols are located on the product information tags located on the product.

	<p>CE Marking on a product is a manufacturer's declaration that the product complies with the essential requirements of the relevant European health, safety and environmental protection legislation, in practice by the Product Directives. CE Marking on a product ensures the free movement of the product within the European Union (EU).</p>
	<p>This directive restricts (with exceptions) the use of six hazardous materials in the manufacture of various types of electronic and electrical equipment. It is closely linked with the Waste Electrical and Electronic Equipment Directive (WEEE) 2002/96/EC which sets collection, recycling and recovery targets for electrical goods and is part of a legislative initiative to solve the problem of huge amounts of toxic e-waste.</p>
	<p>The UL Recognized Component mark is for products intended to be installed in another device, system or end product. This Recognized Component Mark is for the United States only. When a complete product or system containing UL Recognized Components is evaluated, the end-product evaluation process can be streamlined.</p>
	<p>The UL Recognized Component mark is for products intended to be installed in another device, system or end product. This Recognized Component Mark is for the United States and Canada. When a complete product or system containing UL Recognized Components is evaluated, the end-product evaluation process can be streamlined.</p>
	<p>CSA International (Canadian Standards Association), is a provider of product testing and certification services for electrical, mechanical, plumbing, gas and a variety of other products. Recognized in the U.S., Canada and around the world, CSA certification marks indicate that a product, process or service has been tested to a Canadian or U.S. standard and it meets the requirements of an applicable CSA standard or another recognized document used as a basis for certification.</p>
	<p>The UL Listing Mark means UL found that representative product samples met UL's safety requirements. These requirements are primarily based on UL's own published standards for safety. The C-UL-US Mark indicates compliance with both Canadian and U.S. requirements. The products with this type of Mark have been evaluated to Canadian safety requirements and U.S. safety requirements.</p>

Clean Room Certifications:

FlexMove Conveyors are often used in clean room applications where the generation of particulates from the conveyor are a concern. In these applications the correct installation and application of the conveyor is critical to the proper running of the conveyor and minimizing the dust generated by the conveyor belt or modular belt. The end user must ensure that the conveyor belts are properly tracked and product accumulation is minimized to providing minimal dust generation.

All of the FlexMove products are designed and constructed to be used in clean room environments. The following FlexMove Series products have gone through third party testing and certification and are certified for use in ISO Standard 14644-1 Class 5 and Federal Standard 209 Class 100 Clean Room applications.

FlexMove Series Flexible Chain Conveyor

Contact the factory for copy of the certification.



Slide Rail Specifications / Application Data

Part No.	FASR-25 FASR-25K	FASR-25U	FASR-25CD	FASR-25T	FASR-25X	FASR-3E
Material	HDPE	UHMW	Antistatic HDPE	PAPE/Superfric	Impregnated UHMW	HDPE
Color	White	White	Black	Grey	Blue	White
FDA approved	Yes	Yes	No	No	Yes	Yes
Coefficient of Friction	0.3	0.25	0.25	0.22	0.2	0.3
Temp Range	-20 to 60° C	-20 to 60° C	-20 to 60° C	-40 to 1250° C	-20 to 60° C	-20 to 60° C
Maximum Speed	50 M/min	60 M/min	50 M/min	120 M/min	60 M/min	50 M/min
Heavy Loads	Poor	Good	Poor	Excellent	Good	Poor
Elongation / wear resistance	Poor	Good	Poor	Excellent	Good	Poor
Chemical Resistance	Good, poor to petroleum based solvents	Good	Good, poor to petroleum based solvents	Good, not used with wet solvents	Good	Good, poor to petroleum based solvents
Application	General conveyance, lowest cost	High speed, moderate loads, low dust generation	Environments sensitive to static electricity	High speed, high load, dry applications only, abrasive particles	High speed, moderate loads, low dust generation	General conveyance, additional safety for FX series

Chains

Series	FK	FS	FM	FC	FL	FU	FV
<i>Chain width (mm)</i>	44 mm	63 mm	83 mm	103 mm	150 mm	175 mm	255 mm
<i>Chain width (inch)</i>	1.73"	2.48"	3.27"	4.06"	5.91"	6.890"	10.039"
<i>Tensile strength at 20°C (N)</i>	3600 N	3400 N	4800 N	4800 N	4800 N	4800 N	4800 N
<i>Tensile strength at 68°F (lbf)</i>	810 lbf	764 lbf	1079 lbf	1079 lbf	1079 lbf	1079 lbf	1079 lbf
<i>Max. working tensile at 20°C (N)</i>	500 N	500 N	1250 N	1250 N	1250 N	1250 N	1250 N
<i>Max. working tensile at 68°F (lbf)</i>	112 lbf	112 lbf	281 lbf	281 lbf	281 lbf	281 lbf	281 lbf
<i>Working temperature (°C)</i>	-20 – 60°C	-20 – 60°C	-20 – 60°C	-20 – 60°C	-20 – 60°C	-20 – 60°C	-20 – 60°C
<i>Working temperature (°F)</i>	-4 – 140°F	-4 – 140°F	-4 – 140°F	-4 – 140°F	-4 – 140°F	-4 – 140°F	-4 – 140°F
<i>Maximum conveyor speed (m/min)</i>	50 m/min	58 m/min	58 m/min	58 m/min	58 m/min	58 m/min	58 m/min
<i>Maximum conveyor speed (ft/min)</i>	165 ft/min	190 ft/min	190 ft/min	190 ft/min	190 ft/min	190 ft/min	190 ft/min
<i>Max. conveyor length (m)</i>	30 m	30 m	30 m	30 m	30 m	30 m	30 m
<i>Max. conveyor length (ft)</i>	100 ft	100 ft	100 ft	100 ft	100 ft	100 ft	100 ft
<i>Min. turning radius (mm)</i>	150 mm	150 mm	160 mm	170 mm	210 mm	500 mm	700 mm
<i>Min. turning radius (inch)</i>	5.91"	5.91"	6.30"	6.70"	7.87"	19.7"	27.6"
<i>Link spacing (mm)</i>	25.4 mm	25.4 mm	33.5 mm	35.5 mm	35.5 mm	33.5 mm	33.5 mm
<i>Link spacing (inch)</i>	1.0"	1.0"	1.32"	1.40"	1.40"	1.32"	1.32"
<i>Chain weight (plain) (kg/m)</i>	0.63 kg/m	0.75 kg/m	1.20 kg/m	1.67 kg/m	1.87 kg/m	2.0 kg/m	2.43 kg/m
<i>Chain weight (plain) (lb/ft)</i>	0.43 lb/ft	0.50 lb/ft	0.81 lb/ft	1.12 lb/ft	1.26 lb/ft	1.344 lb/ft	1.633 lb/ft
<i>Max. weight on conveyor (kg/m)</i>	30 kg/m	30 kg/m	60 kg/m	60 kg/m	60 kg/m	65 kg/m	65 kg/m
<i>Max. weight on conveyor (lb/ft)</i>	20 lb/ft	20 lb/ft	40 lb/ft	40 lb/ft	40 lb/ft	44 lb/ft	44 lb/ft
<i>Item width (mm)</i>	15 – 100 mm	15-140 mm	20-200 mm	25-300 mm	50-400 mm	50-400 mm	80 – 500 mm
<i>Item width (inch)</i>	0.6 – 4.0"	0.6 – 5.5"	0.8-7.9"	1.0-11.8"	2.0-15.7"	2.0 – 15.4"	3.2 – 19.7"

Series	FKPC -5CD	FSPC -5CD	FMPC -5CD	FCPC -5CD	FLPC -5CD	FUPC -5CD	FVPC -5CD
<i>Tensile strength at 20°C (N)*</i>	1440 N	1360 N	1920 N	1920 N	1920 N	1920 N	1920 N
<i>Tensile strength at 68°F (lbf)*</i>	324 lbf	306 lbf	432 lbf	432 lbf	432 lbf	432 lbf	432 lbf
<i>Max working tensile at 20°C (N)*</i>	200 N	200 N	500 N	500 N	500 N	500 N	500 N
<i>Max working tensile at 68°C (lbf)*</i>	45 lbf	45 lbf	112 lbf	112 lbf	112 lbf	112 lbf	112 lbf

*Strength of conductive chain is 40% of standard chain.

Drive Unit Specifications

Direct Drive unit

	FK	FS	FM	FC	FL	FU	FV
Number of Teeth on sprocket	16	16	12	12	12	12	12
Chain Pitch (mm)	25.4	25.4	33.5	35.5	35.5	33.5	33.5
Max. Traction force (N)	500	500	1250	1250	1250	1250	1250
Sprocket Diameter (mm)	128	128	128	135	135	135	135

Suspended Drive unit

	FK	FS	FM	FC	FL	FU	FV
Number of Teeth on sprocket	16	16	12	12	12	12	12
Chain Pitch (mm)	25.4	25.4	33.5	35.5	35.5	33.5	33.5
Max. Traction force (N)	500	500	1250	1250	1250	1250	1250
Sprocket Diameter (mm)	128	128	128	135	135	135	135

Catenary Drive unit

	FK	FS	FM	FC	FL	FU	FV
Number of Teeth on sprocket	N/A	16	12	12	N/A	N/A	N/A
Chain Pitch (mm)	N/A	25.4	33.5	35.5	N/A	N/A	N/A
Max. Traction force (N)	N/A	500	1250	1250	N/A	N/A	N/A
Sprocket Diameter (mm)	128	128	128	135	N/A	N/A	N/A

Intermediate Drive unit

	FK	FS	FM	FC	FL	FU	FV
Number of Teeth on sprocket	N/A	11	9	9	N/A	N/A	N/A
Chain Pitch (mm)	N/A	25.4	33.5	35.5	N/A	N/A	N/A
Max. Traction force (N)	N/A	200	200	200	N/A	N/A	N/A
Sprocket Diameter (mm)	88	88	98	101	101	N/A	N/A

Wheel Drive unit

	FK	FS	FM	FC	FL	FU	FV
Number of Teeth on sprocket	300	300	320	340	N/A	N/A	N/A
Chain Pitch (mm)	25.4	25.4	33.5	35.5	N/A	N/A	N/A
Max. Traction force (N)	200	200	200	200	N/A	N/A	N/A
Sprocket Diameter (mm)	273	273	277	272	N/A	N/A	N/A

Stand Location

Maximum Distances:

- 1 = 914 mm (36 in)
- 2 = 3048 mm (10 ft)*

* For conveyors longer than 3048 mm (10 ft), install support at joint.

Note: Additional support required on 180° curve modules.

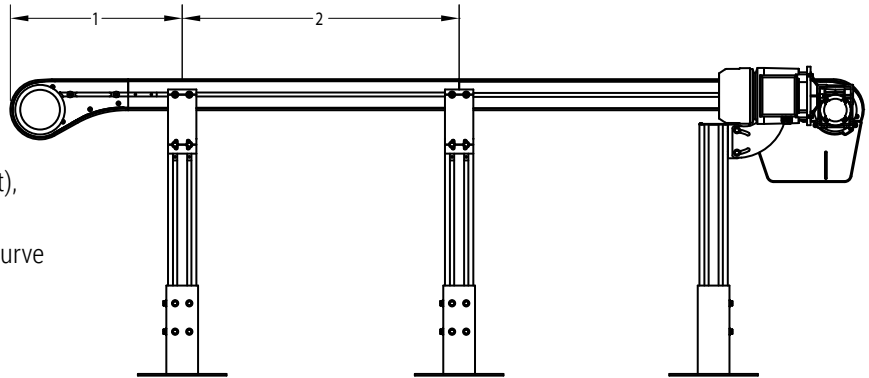

Support must be provided directly at drive end. See accessories for Direct Mount and Suspended Mount support options.

Conveyor Drive Shaft Tolerances:

.75" SHAFT

20 MM SHAFT

OPTIONAL AUXILIARY SHAFT

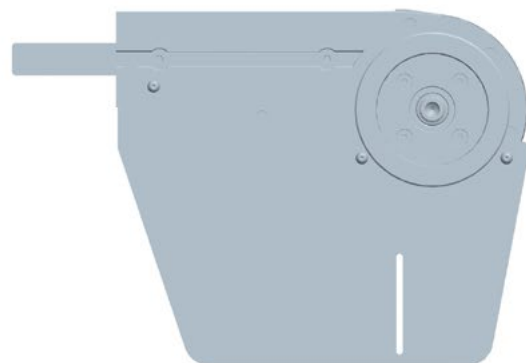
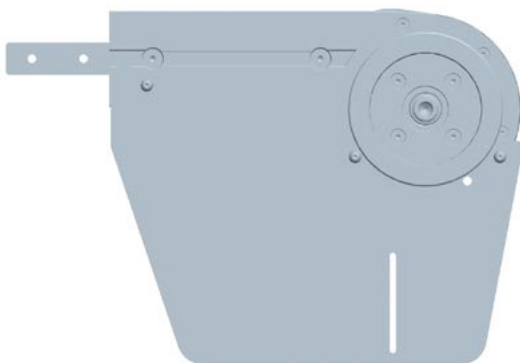
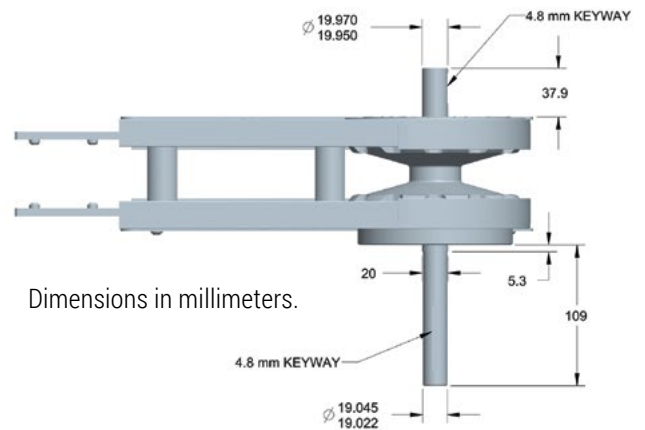
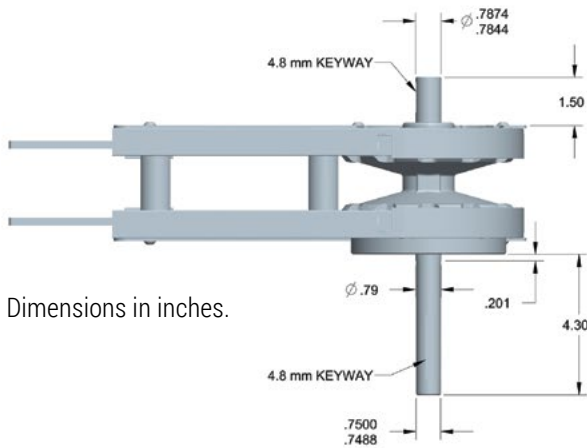

Note: Dimensions = mm (in)

Conveyor Load Capacity

There are several factors that effect the overall conveyor load of the FlexMove conveyor. These include:

- Conveyor size and configuration
- Product accumulation
- Conveyor speed
- Number of starts and stops per hour
- Application temperature
- Maximum Drive Unit Output

Located online at www.dornerconveyors.com is the Dorner conveyor configuration tool, DTools. This tool allows you to configure your conveyor layout and determine the maximum load capacity for the conveyor. It is suggested that this program be used to calculate the conveyor load as the calculation is quite complicated. This configuration program however does not take into account temperature, dirty conditions, and conveyor starts and stops. If these conditions are part of your application, please use the load reducing factors as shown below.

Maximum Load = (Load from DTools) (Temperature Factor) (Start/Stop Factor)

See following pages for factors.

Nominal Maximum Load

A Nominal Maximum Load may be calculated without the use of DTools to determine if the conveyor can generally carry the application load. The following process can be used to calculate Nominal Maximum Load. It **does not** take into account the conveyor configuration. Please confirm your maximum load per application with the Dorner DTools program at www.dornerconveyors.com.

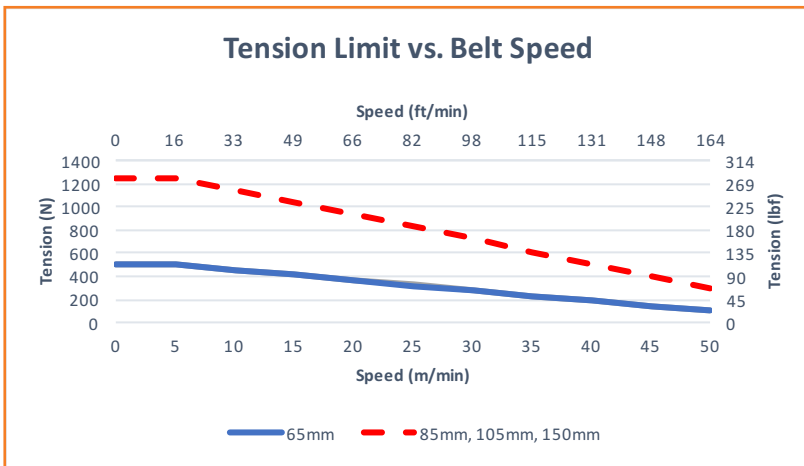

To calculate the Nominal Maximum Load:

Note: This does not include conveyor configuration. Please confirm load with Dorner online DTools configurator.

1. Determine your Basic Tension Limit from the above two graphs. The Basic Tension Limit is the lesser number of the two. Compare your tension limit to drive unit output. Your tension limit is the smaller.
2. Tension Limit = (Basic Tension Limit) (Temperature Factor) (Start/Stop Factor) (Accumulation Factor) (0.7)
See following pages for factors.
3. Nominal Maximum Load (kg) = (Tension Limit / Chain Coefficient of Friction) - (Conveyor length) (2) (Chain weight)

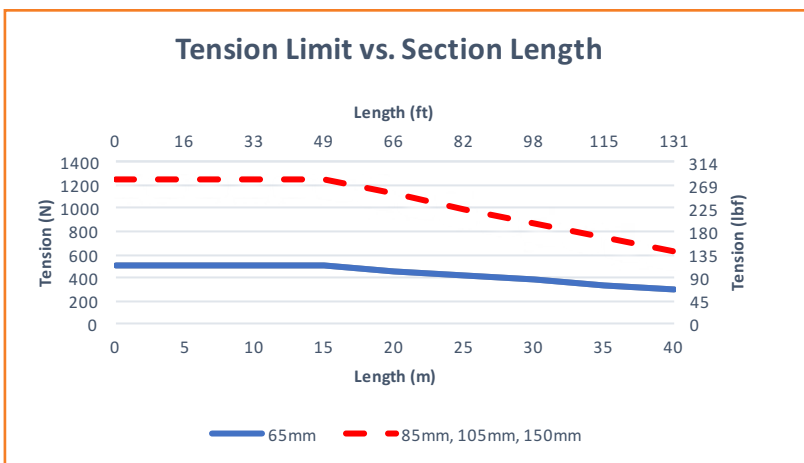

Nominal Maximum Load (lbs) = (Nominal Maximum Load (kg)) (2.2)

See following pages for Chain Coefficient of Friction. Nominal Maximum load may also be limited by available gearmotors. Conformation of gearmotor torque is required. See pages 28-31 for gearmotors available. Nominal Maximum load cannot exceed overall conveyor load limit of 300 lbs (136kg) for 65 mm wide and 600 lbs (273kg) for 105 mm and 150 mm wide.

Nominal Maximum Load *(continued)*

Example:

105 mm FlexMove by 20 meters total length running at 15 Meters/min. Accumulated load with dry metal parts running in a 40°C environment. Continuous running.

- Basic Tension Limit – Tension vs. Speed = 1050N
- Basic Tension Limit – Tension vs. Length = 1100N
- Therefore Basic Tension Limit = 1050N
- Tension Limit = (Basic Tension Limit) (Temperature Factor) (Start/Stop Factor) (Accumulation Factor) (0.7)
- Tension Limit = (1050) (0.9) (1.0) (0.5) (0.7) = 330N
- Nominal Maximum Load (kg) = (Tension Limit / Chain Coefficient of Friction) - (Conveyor length) (2) (Chain weight)
- Nominal Maximum Load (kg) = (330 / 0.3) - (20) (2) (16.4) = 1100 - 984 = 116 kg
- Nominal Maximum Load (lbs) = 116*2.2 = 256 lbs

Temperature Factor		
Ambient temperature can negatively affect the tension capacity of the conveyor chain.		
Temperature (°F)	Temperature (°C)	Temperature Factor
-4	-20	1.0
32	0	1.0
68	20	1.0
104	40	0.9
140	60	0.8

Start / Stop Factor	
Frequent Start / Stops of the conveyor can negatively affect the tension capacity of the conveyor chain. All start / stop applications must use a soft start mechanism such as a Frequency Inverter with a 1 second acceleration cycle.	
Application Condition	Start / Stop Factor
Continuous Run or 1 start/stop per hour	1.00
Maximum 10 starts/stop per hour	0.83
Maximum 30 starts/stop per hour	0.70
Greater than 30 starts/stop per hour	0.62

Accumulation Factor		
Product accumulation greatly reduces the conveyor load capacity. Product accumulation may only be done with the plain chain. Based on the product being accumulated apply the below Accumulation Factor in determining your Nominal Maximum Load. All factors below are assuming dry conditions.		
Product Being Accumulated	Typical Coefficient of Friction	Accumulation Factor
Steel	0.25	0.50
Glass	0.20	0.60
Aluminum	0.25	0.50
Plastic	0.25	0.50
Wood	0.30	0.40
Paper and Cardboard	0.30	0.40

Chain Coefficient of Friction	
The following table provides the coefficient of friction between the standard UHMW wearstrips and the Acetal chain. Coefficient of friction as shown may be reduced by addition of a lubricant.	
Application Condition	Coefficient of Friction
Dry	0.30
Water Lubrication	0.27
Coolant Lubrication	0.20
Oil Lubrication	0.20

Drive Unit Output Capacity, P(W) requirement depend on:

- Traction force F (N)
- Chain speed V (m/min)

To calculate power, the equation is $P = 1/60 (F \times V)$

There are several drive unit designs, the maximum permissible traction force on each type of drive unit as below:

Drive unit type	Maximum traction force in Newton (N)						
	FK	FS	FM	FC	FL	FU	FV
End	500	500	1250	1250	1250	1250	1250
Intermediate	200	200	200	200	200	N/A	N/A
Catenary	500	500	1250	1250	1250	N/A	N/A

Conveyor Noise Level

The actual noise level generated by the conveyor depends on several factors; the installation configuration, the product running on the conveyor, the surrounding equipment, the conveyor options and chain speed. The noise level generated by the conveyor is typically less than the general noise level of factory equipment.

Generally a higher speed chain will result in a higher noise level. In addition, 65 mm conveyors will run slightly quieter, and power transfer tails will add a few decibel points as well. The following charts provide basic decibel ratings for typical conveyor arrangements, such as wheeled and plain bend corners, and power transfers.

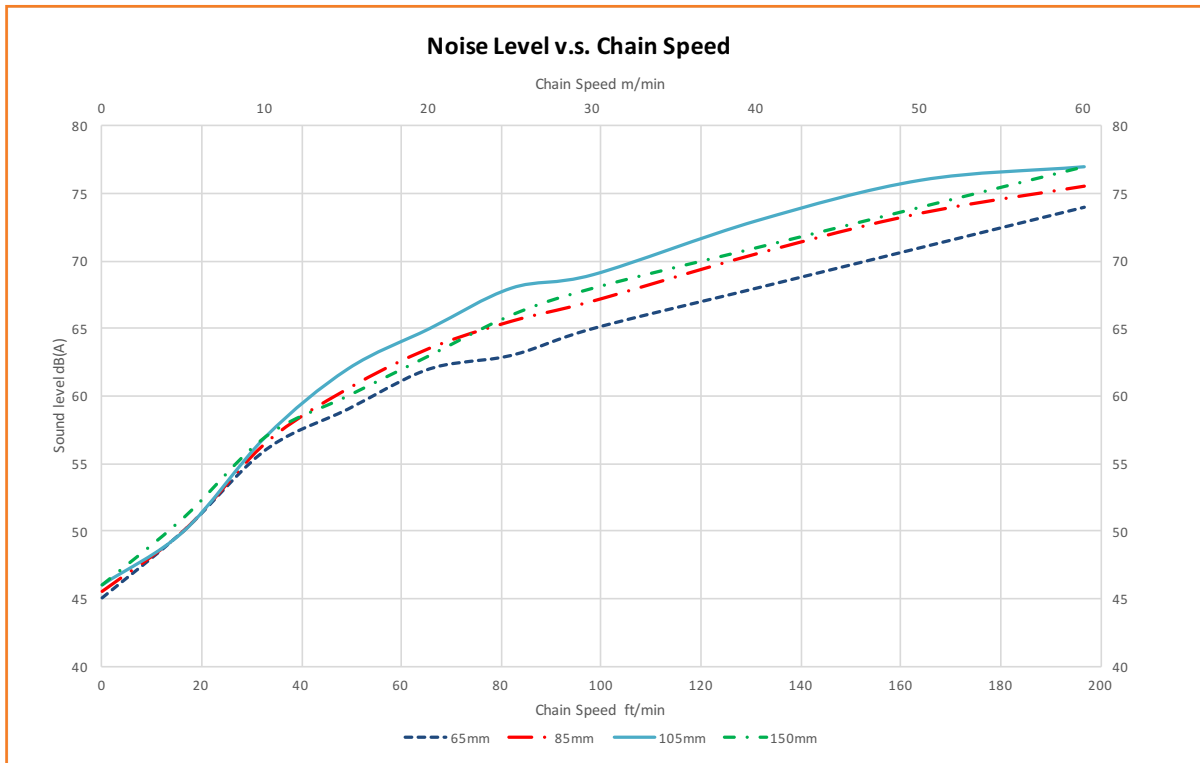

Decibel ratings are taken approximately 3 feet away from the conveyor modules.

Bend Factors

Bend factors must be considered and calculated at every plain chain. It depends on the angle of the bend α in radians and friction coefficient μ between chain and slide rails. In application when conveyor is dry and clean, the friction coefficient μ is close to 0.1.

The bend factor is important to calculate since the frictional force of a plain bend depends not only on the weight of chain and product but also the actual the tension throughout the bend. The result an additional pressure force of the chain towards the conveyor beam directed toward the center of the bend. Since the chain tension varies throughout the conveyor, calculation of this additional pressure force is complicated. The highest values are present at the pulling side of the drive unit and virtually zero at the chain inlet. Using bend factor is the easiest way of including added friction in the plain bend for both horizontal and vertical into the calculation. Always use wheel bend unless for exceptional cases. If using plain bend is a must, the combined plain bends angle should not more than 180°, unless it is for a very short and light application.

Bend type, horizontal or vertical plain bend	Bend factor
30°1	.2
45°	1.3
60°1	.4
90°1	.6

8° inclined is the maximum a product could convey for plain chain whereas friction top chain could take up to 30°

Material

Material	FlexMove Parts
POM (PolyOxyMethylene)	Conveyor Chain, rollers
POM Conductive (PolyOxyMethylene)	Conductive chain
Aluminum, extruded & anodized	Angle bracket, beam support bracket, conveyor beam, support beam, guide rail, distance tube, fixed and adjustable side guide bracket, spacer
Steel, electro-zinc plated	Bolts and nuts, connecting strips, foot connecting strip
Steel, powder coated	Foot, connecting plate
PA, Polyamide	Chain pivot, side guide bracket, side guide support, drive and idler steering guide, end caps, wheel guide
Polyamide PA + Glass fiber	Drive sprocket, idler wheel
PVC, Polyvinyl Chloride	T-slot cover
HDPE, High Density Polyethylene	Slide rail, guide rail
UHMW-PE, Ultra High Molecular Weight Polyethylene	Slide Rail, drive and idler steering guides
PVDF, Polyvinylidene fluoride	Slide Rail
TPE, Thermoplastic Elastomer	Chain insert for friction top and wedge top

Resistance to chemical

FlexMove® components can withstand continuous contact with most chemicals. However, it is recommended to avoid:

- Acids with pH less than 4
- Bases with pH higher than 9

The following table specifies the resistance of several material used in the conveyor on selected chemicals

Legend

1 = Very good

2 = Good

3 = Moderate resistance

4 = Not recommended

5 = No data available

Material	Acetal POM	Polyamide PA	High-density Polyethylene HDPE	Thermoplastic Elastomer TPE	Aluminum AL
Acids:					
Acetic acid	3	4	3	-	2
Benzoic acid	3	4	1	-	4
Citric acid	3	2	2	-	2
Chromic acid	4	4	1	-	3
Hydrofluoric acid	4	4	1	-	4
Hydrochloric acid	4	4	1	-	3
Hydro cyanic acid	4	4	2	-	1
Nitric acid	4	4	4	-	3
Phosphoric acid	4	4	1	-	3
Sulphuric acid	4	4	2	1	3
Tartaric acid	3	2	1	-	1
Basic compounds:					
Ammonia	1	2	1	-	2
Calcium hydroxide	1	2	1	-	4
Caustic soda	1	2	1	1	3
Potassium hydroxide	1	2	1	-	4
Salts:					
Potassium bicarbonate	2	2	2	-	1
Potassium permanganate	2	4	2	-	1
Sodium cyanic	2	2	2	-	4
Sodium hydrochloride	3	4	1	-	4
Acid salt	2	3	1	-	-
Basic salt	1	2	1	-	-
Neutral salt	1	2	1	-	-

Chains

Material	Acetal POM	Polyamide PA	High-density Polyethylene HDPE	Thermoplastic Elastomer TPE	Aluminum AL
Organic compounds and solvents:					
Acetone	1	1	4	3	1
Benzene	1	1	4	3	1
Butyl alcohol	2	2	2	-	1
Carbon disulphide	1	1	3	-	1
Chloroform	1	1	4	-	-
Ethyl acetate	1	1	2	-	1
Ethyl alcohol	1	1	1	-	1
Heptane	2	2	2	-	-
Methyl alcohol	1	1	1	-	2
Methyl ethyl ketone	1	1	4	4	2
Nitrobenzene	2	2	3	-	1
Phenol	3	3	2	-	1
Gasses:					
Carbon dioxide	3	1	1	-	1
Carbon monoxide	2	1	1	-	1
Chlorine	2	4	3	-	1
Hydrogen sulphide	3	1	2	-	1
Sulphur dioxide	2	3	2	-	1
Others:					
Beer	1	2	2	-	1
Fruit juices	1	2	3	-	2
Gasoline	1	2	2	-	1
Milk	1	1	2	-	1
Oil	1	1	2	-	1
Vinegar	1	2	3	-	1

Note: the table above is valid for temperature range up to 60°C and it is to be considered as guideline only. Furthermore, precautions should be taken when using cleaning agents. If you are in doubt on the material to withstand your special environment, you should go for chemical testing or contact our local distributor.

Static Electricity

The standard plastic materials used for conveyors have low electrical conductivity so static electricity can build up in the conveyor. When a conveyor is running under normal environment (20°C and humidity 60%) without load, the static electricity build up should be around the following figures:

Above the drive unit	1800-2500V
Idler end	400-500V
Above the wheel bend	400-500V
Above the straight section	250-350V

With the introduction of anti-static material for slide rail and chain, it shall meet the requirement for electronic industry.

Pallet Plate Details Dimensions

The following details are for standard pallets only. For other size pallets contact Dorner.

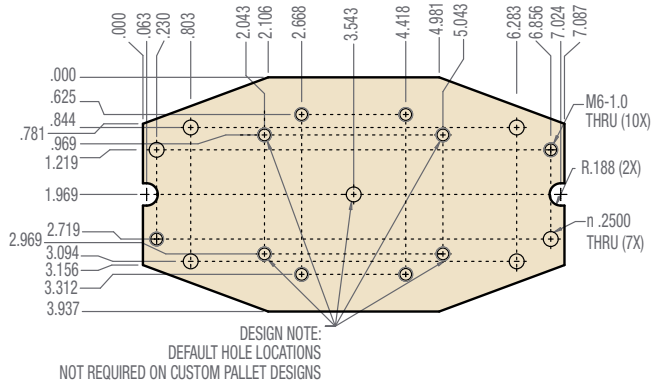

100

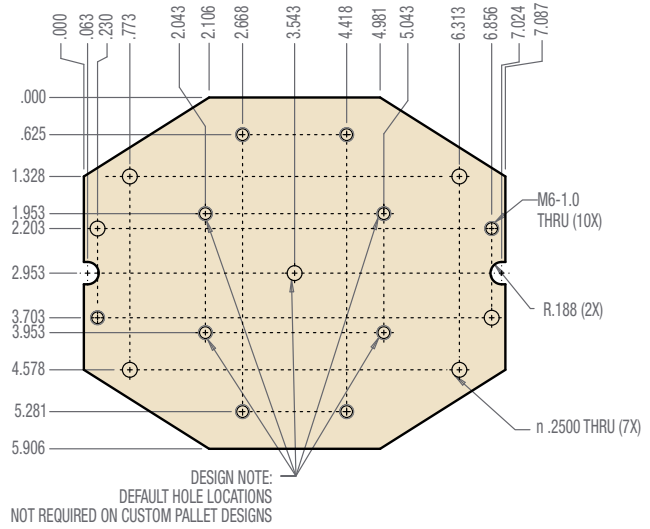

150

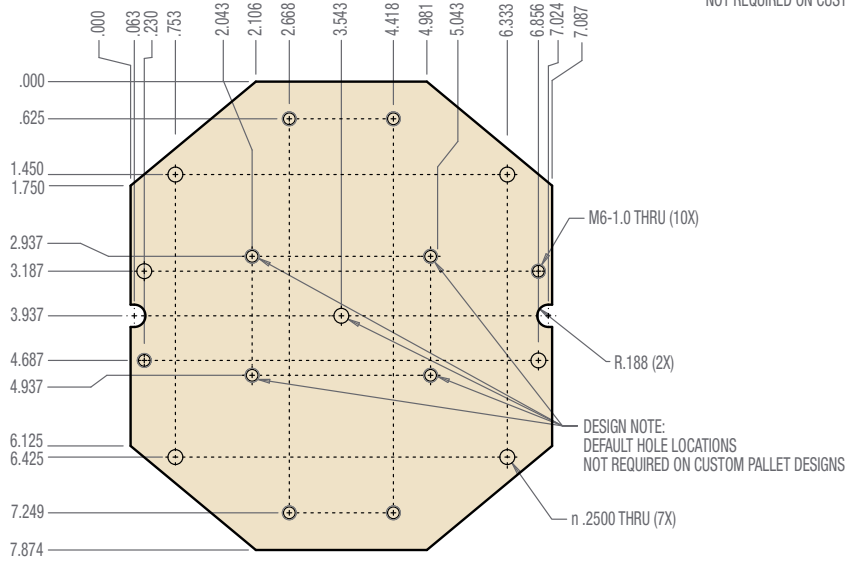

200

Pneumatic Specifications - FlexMove Pallet Modules

Device	Action	Bore Diameter	Stroke Length	Return Type	Sensor Compatible	Force		Fitting			
						per Bar	per Psi	Tap Size	Tube Size		
Lift and Locate	2 lift cylinders	32mm	1.26 in	31 mm	1.22 in	Pneumatic	No	81 N	1.25 lb	R1/8-28	1/4 in
Divert 2 Position	divert cylinder	27 mm	1.06 in	35 mm	1.375 in	Pneumatic	Yes	58 N	0.88 lb	1/8 NPT	1/4 in
Divert 3 Position	extend cylinder	27 mm	1.06 in	33 mm	1.32 in	Pneumatic	Yes	58 N	0.88 lb	1/8 NPT	1/4 in
	middle position	27 mm	1.06 in	13 mm	0.51 in	Pneumatic	Yes	58 N	0.88 lb	1/8 NPT	1/4 in
Cushion Stop	Stop retract	35mm	1.39 in	9 mm	0.35 in	Spring	No	N/A	N/A	M5	1/4 in
Non-cushion Stop	Stop retract	35mm	1.39 in	9 mm	0.35 in	Spring	No	N/A	N/A	M5	1/4 in

FlexMove® Conveyors are best for:

- Part Handling
- Transfers
- Tight Spaces
- Elevation Changes
- Accumulation
- Buffering
- Complex Configurations
- Long Lengths
- Curves, Jogs, Incline, Decline

Sizes & Measurements

- 45 mm, 65 mm, 85 mm, 100 mm, 150 mm, 180 mm & 260 mm (1.7, 2.5, 3, 4, 6, 7 and 10 in) widths
- 0.6 m to 29.8 m (2 to 98 ft) lengths

Loads & Speeds

- Up to 272 kgs (600 lbs)
- Up to 76 meters (250 feet) per minute

Plastic Chain Types

- Standard: Low Friction & Friction Insert
- Specialty
 - Conductive
 - Cleated
 - Roller Top
 - Magnet Top
 - And Many More

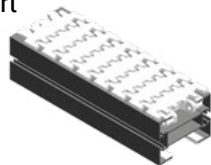

Flat

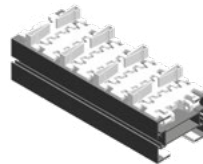

Cleated

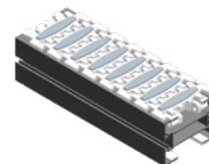

Friction Top

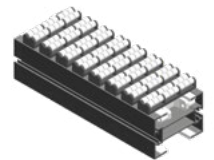

Roller Top

Modules



Drive



Idler



Curve
from 15° to 180°



Incline/Decline
from 5° to 90°

Guiding

- Fully Adjustable Single Rail
- Fully Adjustable Double Rail
- Other Options Available



Support Stands

- Single, Double and Multi Lane Structures Available

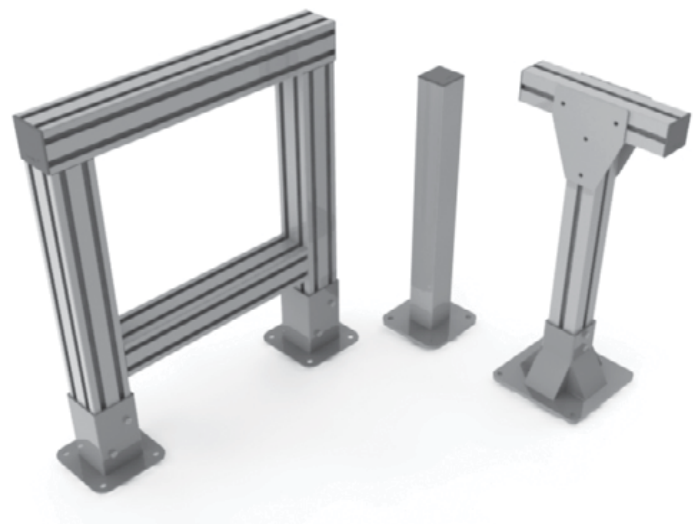



Industrial



Flexible Chain



Pallet Systems



Sanitary Stainless Steel

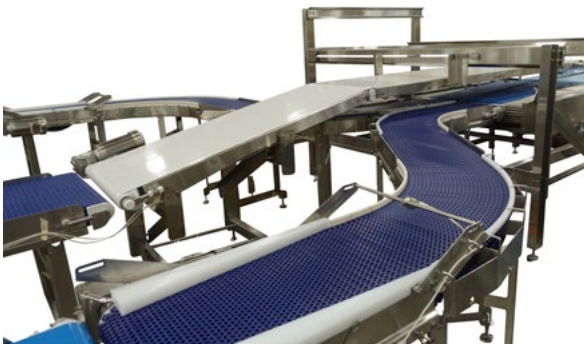

Engineered Solutions Group

Custom engineered solutions for almost any application.

D Tools



CAD Configurator Tool

Industry leading tool! Configure your own custom conveyor in minutes.

TRANSFORMING CONVEYOR AUTOMATION

Contact Dorner

USA
+1-262-367-7600

Canada
+1-289-208-7306

Mexico
+52.33.30037400

Germany
+49 (0) 2461/93767-0

France
+33 (0)1 84 73 24 27

Malaysia
+604-626-2948

DORNER®

By Columbus McKinnon

DORNERCONVEYORS.COM



MAGNETEK

montrate²

CONVEYANCE SOLUTIONS

© Dorner Mfg. Corp. 2024. All Rights Reserved.

851-862-EU-EN 1124