

## PUCK STOP MODULE

- Pneumatic stop for pacing pucks or packages
- Two Models:
  - Vertical Blade Stop; used in pairs as an alternating escapement for pacing round or rounded edge rectangular pucks
  - Horizontal Squeeze Stop; used in combination with Vertical Blade Stop for pacing product without rounded edges. Product must be able to withstand side squeeze pressure
- Compatible with round or rectangular bottles, containers or pucks
- UHMW face for non-marking contact surface
- Includes flow controls with push-in air line connection
- Requires photo sensors, pneumatic solenoid valves, wiring and programming
- Rate depends on product size. Contact factory for details

### FEATURES & SPECIFICATIONS

- Available on FlexMove Aluminum Conveyors, FS (65 mm), FM (85 mm), FC (105 mm), FL (150 mm), FU (180 mm), and FV (260 mm)
- Max. single product weight: 2.3 kg (5 lbs)
- Max. product accumulation weight: 13.6 kg (30 lbs)
- Max. conveyor speed: 50 m/min (164 ft/min)
- Produces gap of approximately one product length (example: FM 85 mm)

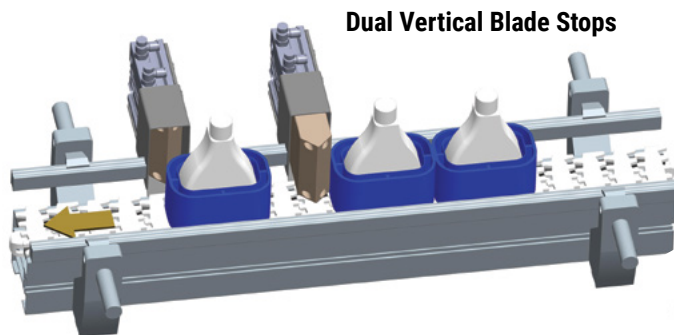
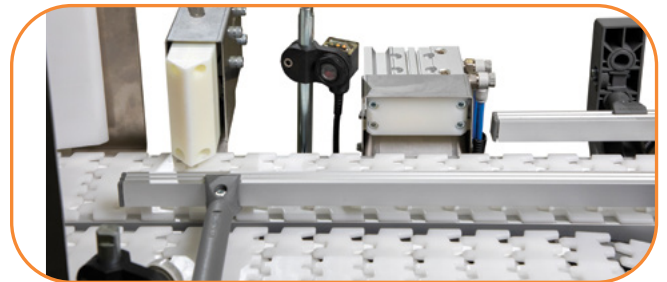

Puck stops alternate to pace products

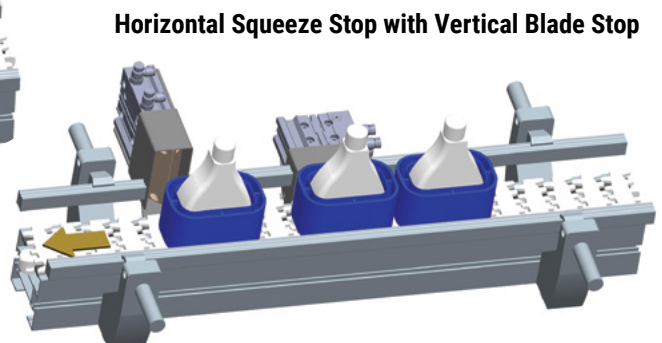

Vertical stop releases product and horizontal stop squeezes second to pace product

## DIMENSIONS

### Vertical Blade

Part Number: 208169

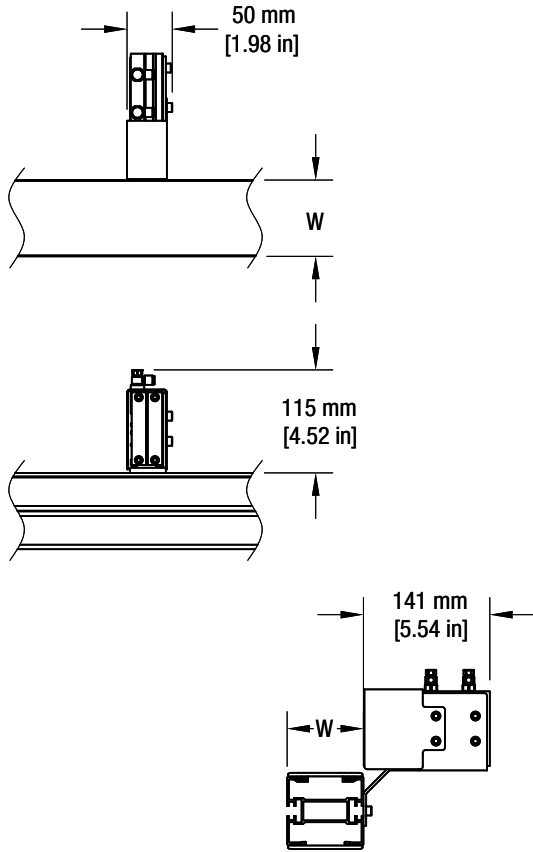

### Horizontal Squeeze

Part Number: 208161

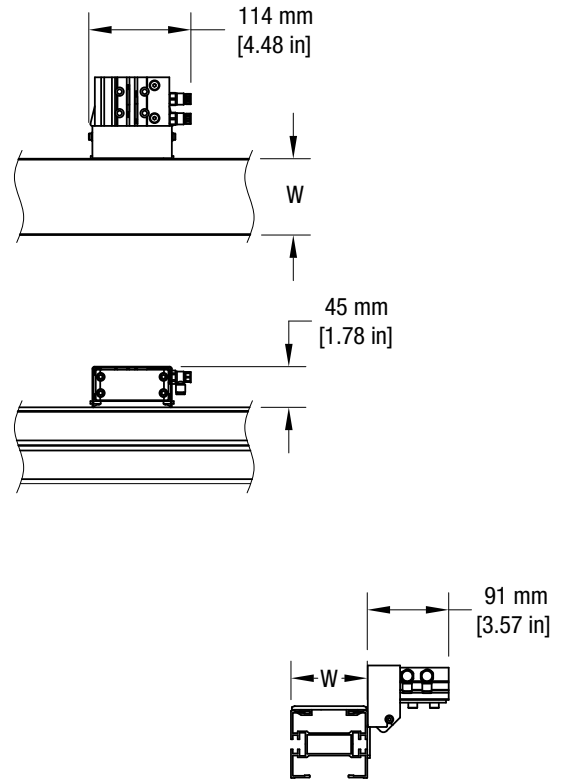

## TRANSFORMING CONVEYOR AUTOMATION

### Dorner – North & South America

Dorner Mfg. Corp.  
USA  
+1-262-367-7600

Dorner Conveyors Ltd.  
Canada  
+1-289-208-7306

Dorner Latin America,  
S. de R.L. de C.V.  
+52.33.30037400

**DORNER**<sup>®</sup>  
By Columbus McKinnon

### Dorner – Europe

Dorner GmbH–Germany  
+49 (0) 2461/93767-0

Dorner SARL–France  
+33 (0)1 84 73 24 27

### Dorner – Asia

Dorner (M) Sdn. Bhd.  
Malaysia  
+604-626-2948

[dornerconveyors.com](http://dornerconveyors.com)

© Dorner Mfg. Corp. 2024.  
All Rights Reserved.  
851-954 0924